



IEC 61851-23

Edition 2.0 2023-12

# INTERNATIONAL STANDARD



---

**Electric vehicle conductive charging system –  
Part 23: DC electric vehicle supply equipment**





**THIS PUBLICATION IS COPYRIGHT PROTECTED**  
**Copyright © 2023 IEC, Geneva, Switzerland**

All rights reserved. Unless otherwise specified, no part of this publication may be reproduced or utilized in any form or by any means, electronic or mechanical, including photocopying and microfilm, without permission in writing from either IEC or IEC's member National Committee in the country of the requester. If you have any questions about IEC copyright or have an enquiry about obtaining additional rights to this publication, please contact the address below or your local IEC member National Committee for further information.

IEC Secretariat  
3, rue de Varembe  
CH-1211 Geneva 20  
Switzerland

Tel.: +41 22 919 02 11  
[info@iec.ch](mailto:info@iec.ch)  
[www.iec.ch](http://www.iec.ch)

**About the IEC**

The International Electrotechnical Commission (IEC) is the leading global organization that prepares and publishes International Standards for all electrical, electronic and related technologies.

**About IEC publications**

The technical content of IEC publications is kept under constant review by the IEC. Please make sure that you have the latest edition, a corrigendum or an amendment might have been published.

**IEC publications search - [webstore.iec.ch/advsearchform](http://webstore.iec.ch/advsearchform)**

The advanced search enables to find IEC publications by a variety of criteria (reference number, text, technical committee, ...). It also gives information on projects, replaced and withdrawn publications.

**IEC Just Published - [webstore.iec.ch/justpublished](http://webstore.iec.ch/justpublished)**

Stay up to date on all new IEC publications. Just Published details all new publications released. Available online and once a month by email.

**IEC Customer Service Centre - [webstore.iec.ch/csc](http://webstore.iec.ch/csc)**

If you wish to give us your feedback on this publication or need further assistance, please contact the Customer Service Centre: [sales@iec.ch](mailto:sales@iec.ch).

**IEC Products & Services Portal - [products.iec.ch](http://products.iec.ch)**

Discover our powerful search engine and read freely all the publications previews. With a subscription you will always have access to up to date content tailored to your needs.

**Electropedia - [www.electropedia.org](http://www.electropedia.org)**

The world's leading online dictionary on electrotechnology, containing more than 22 300 terminological entries in English and French, with equivalent terms in 19 additional languages. Also known as the International Electrotechnical Vocabulary (IEV) online.



IEC 61851-23

Edition 2.0 2023-12

# INTERNATIONAL STANDARD



---

**Electric vehicle conductive charging system –  
Part 23: DC electric vehicle supply equipment**

INTERNATIONAL  
ELECTROTECHNICAL  
COMMISSION

---

ICS 43.120

ISBN 978-2-8322-7961-8

**Warning! Make sure that you obtained this publication from an authorized distributor.**

## CONTENTS

FOREWORD.....	15
1 Scope.....	18
2 Normative references .....	19
3 Terms and definitions .....	22
3.1 Electric supply equipment .....	22
3.2 Insulation .....	22
3.3 Functions .....	26
3.4 Vehicle .....	30
3.5 Cords, cables and connection means .....	31
3.6 Service and usage .....	32
3.7 General terms .....	33
4 General requirements .....	40
5 Classification .....	40
5.101 Characteristics of EV supply equipment .....	40
5.101.1 Separation type .....	40
5.101.2 Control system .....	40
5.101.3 System .....	40
5.101.4 Thermal management system .....	40
5.101.5 Power distribution system .....	41
6 Charging modes and functions .....	41
6.2 Charging modes.....	41
6.2.1 Mode 1 .....	41
6.2.2 Mode 2 .....	41
6.2.3 Mode 3 .....	41
6.3 Functions provided in Mode 4 .....	41
6.3.1 Mandatory functions in Mode 4 .....	41
6.3.2 Optional functions for Mode 4 .....	62
7 Communications .....	63
7.1 Digital communication between the EV supply equipment and the EV .....	63
7.1.101 Basic communication interface .....	64
8 Protection against electric shock .....	64
8.101 General provisions.....	64
8.101.1 General .....	64
8.101.2 Intended use and reasonably foreseeable misuse.....	65
8.101.3 Limitation of touch current or touch voltage .....	65
8.101.4 Threshold of perception and startle reaction .....	65
8.102 Basic protection .....	68
8.102.1 General .....	68
8.102.2 Protection by means of basic insulation of live parts .....	68
8.102.3 Protection by means of enclosures or barriers .....	68
8.102.4 Protection by means of limitation of voltage.....	68
8.102.5 Protection by means of limitation of steady-state touch current.....	70
8.103 Fault protection.....	70
8.103.1 General .....	70
8.103.2 Protective-equipotential-bonding.....	70

8.103.3	Effective protective conductor continuity between the enclosure and the external protective circuit.....	70
8.103.4	Automatic disconnection of supply .....	71
8.103.5	Supplementary insulation.....	71
8.103.6	Electrically protective screening .....	71
8.104	Enhanced protective provision .....	71
8.104.1	General .....	71
8.104.2	Double or reinforced insulation .....	71
8.104.3	Protective separation between circuits.....	72
8.105	Requirements for separated EV supply equipment .....	72
8.105.1	General .....	72
8.105.2	Equipotential bonding on side B.....	74
8.105.3	Impedance to protective conductor on side B.....	74
8.105.4	Degrees of protection against access to hazardous-live-parts.....	75
8.105.5	Insulation barriers.....	76
8.105.6	Stored energy.....	77
8.105.7	Disconnection from vehicle .....	78
8.105.8	Protective (earthing) conductor from the supply network.....	78
8.105.9	Residual current protective devices .....	79
8.105.10	Safety requirements for auxiliary circuits between the EV supply equipment and the EV .....	79
8.105.11	Protective conductor dimension cross-sectional area.....	79
9	Conductive electrical interface requirements.....	80
9.1	General.....	80
9.5	Functional description of the DC interface.....	80
9.7	Wiring of the neutral conductor .....	80
9.101	Avoidance of breaking under load.....	80
10	Requirements for adaptors .....	81
11	Cable assembly requirements.....	82
11.1	General.....	82
11.6	Strain relief.....	82
11.6.101	Strain relief of the EV supply equipment's side B cable assembly .....	82
11.6.102	Test of the anchorage of the side B cable assembly .....	83
11.101	Cable breakaway .....	85
11.102	Surface temperature of the side B cable assembly.....	85
12	EV supply equipment constructional requirements and tests.....	87
12.1	General.....	87
12.2	Characteristics of mechanical switching devices .....	87
12.2.5	Relays .....	87
12.3	Clearances and creepage distances.....	87
12.4	IP degrees .....	87
12.4.1	Degrees of protection against solid foreign objects and water for the enclosures.....	87
12.5	Insulation resistance .....	88
12.6	Touch current .....	88
12.6.101	Touch current limit.....	88
12.6.102	Test.....	88
12.6.103	Protection measures for the test touch current more than 3,5 mA .....	89
12.7	Dielectric withstand voltage .....	90

12.7.2	Impulse dielectric withstand (1,2 µs/50 µs)	90
12.7.101	Suppression of transient overvoltage at side A (insulation coordination)	90
12.7.102	Protection against transient overvoltages of atmospheric origin or due to switching	92
12.8	Temperature rise	94
12.9	Damp heat functional test	94
12.10	Minimum temperature functional test	94
12.11	Mechanical strength	94
12.101	Side A current	95
12.102	Power supply cords	96
12.102.1	General	96
12.102.2	Cross-sectional area	96
12.102.3	Cord anchorages and strain relief for non-detachable power supply cords	97
12.103	Stress relief test	98
12.104	Abnormal operation and simulated fault condition tests	99
12.104.1	General	99
12.104.2	Pass criteria	99
12.104.3	Breakdown of components test	100
12.104.4	Loss of AC supply phase test	100
12.104.5	Inoperative blower/fan motor test	100
12.104.6	Clogged filter test	101
12.105	Protection against electrically caused fire	101
12.105.1	General	101
12.105.2	Fire enclosure	101
12.106	Protection against chemical hazards	101
12.106.1	Type of coolant	101
12.106.2	Flammability	102
12.106.3	Material compatibility	102
12.107	Enclosures	102
12.107.1	General	102
12.107.2	Strength of materials and parts	103
12.107.3	Enclosure integrity tests	103
12.108	Components bridging insulation	103
12.108.1	General	103
12.108.2	Capacitors	104
12.109	Isolating transformers	104
13	Overload and short-circuit protection	104
13.1	General	104
13.2	Overload protection of the cable assembly	104
13.3	Short-circuit protection of the charging cable	104
13.101	Short-circuit protection of the DC connection during energy transfer	105
14	Automatic reclosing of protective devices	106
15	Emergency switching or disconnect (optional)	106
16	Marking and instructions	106
16.1	Installation manual of EV charging stations	106
16.2	User manual for EV supply equipment	107
16.3	Marking of EV supply equipment	108
16.4	Marking of charging cable assemblies case B	108

101	Specific requirements for EV supply equipment .....	108
101.1	Specific requirements for separated EV supply equipment .....	108
101.1.1	Operating ranges for voltage, current, and power at side B.....	108
101.1.2	Voltage and current tolerance at side B .....	109
101.1.3	Control delay of present current at side B in CCM .....	111
101.1.4	Descending rate of present current at side B .....	114
101.1.5	Periodic and random deviation (current ripple at side B during CCM).....	114
101.1.6	Periodic and random deviation (voltage ripple at side B during CVM) .....	115
101.1.7	Load dump .....	117
101.1.8	Side B inductance.....	117
101.2	Specific requirement for energy transfer with a thermal management system or thermal sensing only .....	118
101.2.1	General .....	118
101.2.2	Temperature limits and self-diagnostics .....	118
101.2.3	Temperature monitoring.....	119
101.2.4	Tests for thermal management system performance of the EV supply equipment .....	120
101.3	Specific requirements for temperature-controlled energy transfer .....	129
102	Test methods.....	130
102.1	Technical data .....	130
102.2	General test conditions .....	130
102.2.1	Ambient test conditions.....	130
102.2.2	Measuring instruments .....	131
102.2.3	Test setups.....	131
102.2.4	Test load .....	134
102.2.5	Operating points for tests .....	136
Annexes	.....	138
Annex AA (normative)	EV supply equipment of system A.....	139
AA.1	General.....	139
AA.2	Circuit diagram .....	139
AA.3	Specific safety requirements .....	142
AA.3.1	Fault protection in side B .....	142
AA.3.2	De-energization of the power supply to the EV .....	146
AA.3.3	Voltage measurement of side B live parts (DC+/DC–) for vehicle connector unlatch .....	147
AA.3.4	Overcurrent protection of side B .....	147
AA.3.5	Short-circuit protection of side B.....	147
AA.3.6	Latch monitoring for the vehicle connector.....	148
AA.3.7	Protection of the EV disconnection device .....	149
AA.3.8	Fault conditions and criteria for transfer to error and emergency shutdown .....	149
AA.3.9	Inrush current limitation by the EV supply equipment.....	154
AA.3.10	Regulation of the present current at side B in CCM.....	155
AA.3.11	Periodic and random deviation (current ripple at side B during CCM).....	156
AA.3.12	Overvoltage protection including load dump.....	157
AA.3.13	Power supply to the EV for the actuation of EV disconnection device .....	158
AA.3.14	Impedance of the side B circuit.....	158
AA.3.15	Assistance of welding detection .....	158
AA.3.16	Specific requirements for temperature-controlled energy transfer .....	159

AA.4	FPT process and communication between the EV supply equipment and the EV for energy transfer control .....	159
AA.4.1	Forward power transfer states .....	159
AA.4.2	Communication measures.....	161
AA.4.3	Forward power transfer control process .....	162
AA.4.4	Measuring current and voltage at side B .....	168
AA.5	Response to an EV command on charge current.....	170
AA.6	Bidirectional power transfer (optional).....	172
AA.6.1	General .....	172
AA.6.2	Circuit diagram .....	172
AA.6.3	Functional requirements .....	174
AA.6.4	Bidirectional power transfer control process.....	176
AA.7	Optional functions .....	181
AA.7.1	General .....	181
AA.7.2	Compatibility check.....	181
AA.7.3	Dynamic control.....	181
AA.7.4	High-current control .....	182
AA.7.5	High-voltage control.....	182
AA.8	Compliance test for user-initiated shutdown .....	182
AA.9	Specific requirement for energy transfer with thermal management system.....	183
Annex BB (normative)	EV supply equipment of system B.....	184
BB.1	General.....	184
BB.2	Circuit diagrams.....	184
BB.2.1	Circuit diagram .....	184
BB.2.2	Requirements of IMD and discharge circuit.....	186
BB.3	Parameters of control pilot circuit.....	186
BB.4	Forward power transfer control process under normal condition .....	187
BB.4.1	Side B regulation .....	187
BB.4.2	Measuring current and voltage.....	187
BB.4.3	Vehicle coupler mating confirmation .....	189
BB.4.4	Forward power transfer control sequence .....	189
BB.4.5	Normal shutdown.....	191
BB.5	Safety requirements under failure mode.....	191
BB.5.1	Error shutdown and emergency shutdown.....	191
BB.5.2	Terminate energy transfer due to an EV supply equipment fault.....	193
BB.5.3	Terminate energy transfer due to an EV fault.....	194
BB.5.4	Digital communication timeout .....	194
BB.5.5	Loss of electrical continuity of the control pilot.....	195
BB.5.6	Overvoltage fault .....	195
BB.5.7	Load dump .....	196
BB.5.8	Short-circuit protection of side B.....	197
BB.5.9	Lock and latch monitoring for vehicle connector.....	198
BB.5.10	Overcurrent protection of side B .....	198
BB.5.11	Insulation fault monitoring.....	198
BB.6	Timing sequence diagram of forward power transfer .....	199
BB.7	Side B current regulation in CCM.....	200
BB.8	Insulation resistance check before energy transfer.....	202
BB.9	Side B voltage regulation in CVM.....	204
BB.10	Periodic and random deviation (voltage ripple at side B in CVM).....	206

BB.11	Energy transfer control mode .....	206
BB.11.1	Definition .....	206
BB.11.2	Typical forward power transfer process .....	207
BB.12	Standby mode .....	208
BB.13	Smart charging .....	209
BB.14	Minimum cross-sectional area of the protective conductor .....	209
Annex CC	(normative) EV supply equipment of system C .....	210
CC.1	General .....	210
CC.2	Circuit diagrams .....	210
CC.2.1	General .....	210
CC.2.2	Circuit diagram for configuration EE .....	210
CC.2.3	Circuit diagram for configuration FF .....	213
CC.2.4	Disabled side B .....	216
CC.3	Process of energy transfer .....	217
CC.3.1	General .....	217
CC.3.2	Normal startup .....	219
CC.3.3	Normal shutdown or pause after energy transfer .....	225
CC.3.4	Error and emergency handling .....	229
CC.3.5	Pause by EV supply equipment using ISO 15118-2:2014 .....	241
CC.3.6	Renegotiation initiated by EV or EV supply equipment using ISO 15118-2:2014 .....	251
CC.4	Safety related functions .....	255
CC.4.1	Safety measures for side B .....	255
CC.4.2	Vehicle coupler latching function .....	259
CC.4.3	Loss of electrical continuity of the control pilot conductor .....	259
CC.4.4	Loss of electrical continuity of the proximity detection conductor .....	259
CC.4.5	Voltage check at initialization .....	259
CC.4.6	Minimum cross-sectional area of the protective conductor .....	259
CC.4.7	Loss of electrical continuity of the protective conductor .....	259
CC.5	Additional functions .....	260
CC.5.1	Pre-charge .....	260
CC.5.2	Sleep mode and communication session restart methods .....	262
CC.5.3	Configuration EE vehicle connector latch position switch (S <sub>S3</sub> ) activation .....	269
CC.5.4	Configuration EE vehicle connector latch position switch (S <sub>S3</sub> ) verification .....	269
CC.5.5	Handling of operating ranges .....	270
CC.5.6	Compatibility check .....	277
CC.5.7	Considerations for CCM, CVM and CPM (informative) .....	281
CC.6	Specific requirements .....	283
CC.6.1	Requirements for load dump .....	283
CC.6.2	Side B current regulation .....	283
CC.6.3	Measuring current and voltage at side B .....	283
CC.6.4	Overcurrent protection of side B .....	284
CC.7	General test conditions .....	284
CC.7.1	Operating points – Definitions .....	284
CC.7.2	Standard test setup .....	286
CC.7.3	Definition of measured values at side B .....	286
CC.7.4	Exemplary approach to set a test point in CCM .....	286

CC.7.5	Test cases .....	289
CC.7.6	Wake up of EV supply equipment by EV .....	293
Annex DD (informative)	Bidirectional power transfer control .....	354
DD.1	General.....	354
DD.2	Forward power transfer (FPT) and reverse power transfer (RPT) .....	354
Annex EE (normative)	Test load impedance verification.....	355
EE.1	General.....	355
EE.2	Response curve verification .....	355
EE.3	Test setup for test load verification (informative).....	358
EE.4	Result .....	359
Annex FF (normative)	Multi-side B separated EV supply equipment.....	360
FF.1	General.....	360
FF.2	Classification and use case of multi-side B EV supply equipment.....	360
FF.2.1	System operation.....	360
FF.2.2	Side B system .....	360
FF.2.3	Configuration .....	360
FF.3	Constructional requirements of a side B system.....	363
FF.3.1	Constructional requirements of a side B system according to Annex AA .....	363
FF.3.2	Constructional requirements of a side B system according to Annex BB .....	364
FF.3.3	Constructional requirements of a side B system according to Annex CC .....	364
FF.4	Side B system performance .....	364
FF.4.1	General performance requirements.....	364
FF.4.2	Performance of multi-side B EV supply equipment providing simultaneous operation.....	364
FF.5	Safety requirements.....	364
FF.5.1	General safety requirements.....	364
FF.5.2	Short-circuit protection .....	365
FF.5.3	Overload protection .....	365
FF.5.4	Access to live parts through an unmated vehicle connector during energy transfer .....	365
FF.5.5	Additional safety requirements for multi-side B EV supply equipment providing simultaneous operation .....	366
FF.5.6	Diagnostic check of mechanical disconnection device in the side B system.....	366
FF.5.7	Interconnected side B live parts (DC+/DC-) in multi-side B EV supply equipment .....	366
Annex GG (informative)	Communication and energy transfer process between the EV supply equipment and the EV .....	367
GG.1	General.....	367
GG.2	System configuration .....	367
GG.3	Energy transfer control process and state .....	367
GG.3.1	General .....	367
GG.3.2	Description of the initialization stage .....	368
GG.3.3	Description of the energy transfer stage .....	368
GG.3.4	Description of the shutdown stage .....	369
Annex HH (informative)	Touch current and touch impulse current.....	370
HH.1	General.....	370
HH.2	Current through the human body.....	375
HH.3	Conditional dependent thresholds .....	376

HH.4	Hazards due to leakage between side B live parts and the protective conductor .....	376
HH.5	Balanced versus unbalanced voltages at side B live parts (DC+/DC-) .....	377
HH.6	Insulation monitoring device .....	378
HH.7	IMD reaction time .....	379
HH.8	Conclusion .....	379
	Bibliography .....	380
Figure 101	– Example of a coupling session .....	27
Figure 102	– Voltage $V_{T8}$ to apply to simulate short period overvoltage at side B between DC+ and DC- .....	52
Figure 103	– Typical voltages between side B live parts (DC+/DC-) and protective conductor under normal operation .....	55
Figure 104	– IMD connection which results in a voltage more than the maximum voltage limits .....	56
Figure 105	– Examples of a fault between the secondary circuit and the protective conductor .....	59
Figure 106	– Measurement of the touch leakage current .....	67
Figure 107	– Touch time – DC voltage under single fault condition (water wet, fingertip to feet) .....	69
Figure 108	– Insulation barriers .....	76
Figure 109	– Construction types of vehicle adapters .....	81
Figure 110	– Apparatus to test the side B cable assembly anchorage .....	83
Figure 111	– Test setup the side B cable assembly anchorage .....	84
Figure 112	– Example of a side B cable assembly equipped with handle and a warning label attached to the cable .....	86
Figure 113	– Example setup of SPD for the protection of the EV supply equipment against transients .....	91
Figure 114	– Example of an SPD-assembly having one voltage switching type SPD between side B live conductors (DC+/DC-) and protective conductor .....	93
Figure 115	– Symbol ISO 7000-0434B:2004-01 .....	107
Figure 116	– Side B voltage tolerances in CVM .....	110
Figure 117	– Current control delay for an increasing current request .....	112
Figure 118	– Current control delay for a decreasing current control request .....	113
Figure 119	– Voltage at side B in CVM operation in steady state with ripple .....	116
Figure 120	– Setup to measure the maximum side B inductance .....	117
Figure 121	– Reference device (RD) A_0 .....	121
Figure 122	– Test arrangement A_0 .....	122
Figure 123	– Reference device RD A_1 .....	122
Figure 124	– Test arrangement A_1 .....	123
Figure 125	– Reference device RD C_0 .....	124
Figure 126	– Test arrangement C_0 .....	125
Figure 127	– Reference device RD C_1 .....	125
Figure 128	– Test arrangement C_1 .....	126
Figure 129	– General test setup for system A .....	132
Figure 130	– General test setup for system B .....	133

Figure 131 – General test setup for system C .....	134
Figure 132 – Test load example .....	135
Figure 133 – Operating points .....	137
Figure AA.1 – Overall circuit diagram of system A EV supply equipment and EV .....	140
Figure AA.2 – Failure detection principle by detection of DC leakage current .....	144
Figure AA.3 – Example of vehicle connector latch monitoring circuit .....	148
Figure AA.4 – Example of vehicle inlet with the latch holder covered by a metal plate that inhibits latch holding .....	149
Figure AA.5 – Flow diagram for forward power transfer .....	162
Figure AA.6 – Sequence diagram for forward power transfer .....	163
Figure AA.7 – Representation of the delay between the measurement and the digital communication transmission for system A .....	169
Figure AA.8 – Acceptable range of the measured current at side B (target current of the EV $I_{EV\_trg} = 50$ A) .....	170
Figure AA.9 – Change in the target current requested by the EV .....	171
Figure AA.10 – Side B performance of EV supply equipment .....	172
Figure AA.11 – Circuit diagram of a system A BPT EV supply equipment and EV .....	173
Figure AA.12 – Flow diagram for bidirectional power transfer .....	179
Figure AA.13 – Sequence diagram for bidirectional power transfer .....	180
Figure AA.14 – Transition of applicable maximum current of the EV supply equipment at side B and target current of the EV during dynamic control .....	181
Figure BB.1 – System B EV supply equipment circuit diagram .....	185
Figure BB.2 – Representation of delay between the measures current and voltage at side B and the digital communication transmission for system B .....	187
Figure BB.3 – FPT control sequence for system B .....	190
Figure BB.4 – Timing sequence diagram of FPT .....	200
Figure BB.5 – Operating points and test points for side B current regulation in CCM .....	201
Figure BB.6 – Operating points and test points for side B voltage regulation in CVM .....	206
Figure BB.7 – Definition of CCM, CVM and CPM .....	207
Figure BB.8 – Typical FTP process .....	208
Figure CC.1 – Circuit diagram for a system C EV supply equipment of configuration EE .....	211
Figure CC.2 – Circuit diagram of a system C EV supply equipment of configuration FF .....	214
Figure CC.3 – Equivalent disabled side B of the EV supply equipment .....	216
Figure CC.4 – Example of a sequence diagram .....	219
Figure CC.5 – Sequence diagram for normal startup .....	220
Figure CC.6 – Sequence diagram for normal shutdown or pause after energy transfer by EV or EV supply equipment .....	226
Figure CC.7 – Sequence diagram for EV supply equipment and EV initiated error shutdown .....	230
Figure CC.8 – Sequence diagram for EV initiated error shutdown based on DIN SPEC 70121 during energy transfer .....	233
Figure CC.9 – Sequence diagram for an emergency shutdown executed by the EV .....	236
Figure CC.10 – Sequence diagram for an emergency shutdown executed by the EV supply equipment .....	239
Figure CC.11 – Sequence diagram for pause before cable-check phase by EV supply equipment using ISO 15118-2:2014 .....	242

Figure CC.12 – Sequence diagram for pause after pre-charge phase and before energy transfer stage by the EV supply equipment using ISO 15118-2:2014 .....	246
Figure CC.13 – Sequence diagram for renegotiation initiated by EV or EV supply equipment using ISO 15118-2:2014 .....	252
Figure CC.14 – Worst case equivalent circuit during pre-charge .....	260
Figure CC.15 – Restart methods sequence for the EV supply equipment .....	263
Figure CC.16 – Restart method verification on the EV supply equipment .....	264
Figure CC.17 – Example of a B1 – B2 transition .....	265
Figure CC.18 – Example of a B1 – E – B1 – B2 transition .....	266
Figure CC.19 – Example of a B1 – F – B1 – B2 transition .....	266
Figure CC.20 – Restart methods sequence for the EV .....	268
Figure CC.21 – Example of a B – C – B toggle.....	269
Figure CC.22 – Operating points.....	285
Figure CC.23 – Approaching a single test point TP in CCM (example 1) .....	288
Figure CC.24 – Approaching multiple test points $TP_n$ CCM (example 2).....	289
Figure CC.25 – Test points $TP_n$ .....	298
Figure CC.26 – Voltage at the vehicle connector.....	306
Figure CC.27 – Test points $TP_n$ for the load dump test .....	309
Figure CC.28 – Test point matrix for side B current regulation in CCM including static deviation and ripple .....	314
Figure CC.29 – Test point sequence for side B current regulation in CCM .....	317
Figure CC.30 – Test point matrix for 0 A mode during energy transfer .....	318
Figure CC.31 – Test point matrix for side B voltage regulation in CVM during pre-charge .....	321
Figure CC.32 – Test point matrix for control delay of charging current in CCM.....	327
Figure CC.33 – Test point sequence .....	329
Figure CC.34 – Test points for voltage measurement during welding detection .....	344
Figure CC.35 – Test setup for IMD measurement connections .....	351
Figure EE.1 – Magnitude of the impedance of the test load between DC+ and DC– for system A and system B.....	356
Figure EE.2 – Magnitude of the impedance of the test load between DC+ and DC– for system A for current ripple measurements .....	357
Figure EE.3 – Magnitude of the impedance of the test load between DC+ and DC– for system C .....	357
Figure EE.4 – Test setup for test load verification .....	358
Figure FF.1 – Example of a multi-side B EV supply equipment with a single PEC .....	362
Figure FF.2 – Example of a multi-side B EV supply equipment with multiple PECs.....	363
Figure HH.1 – EV and EV supply equipment equivalent circuit .....	370
Figure HH.2 – Circuit diagram simplification of the circuit in Figure HH.1 .....	373
Figure HH.3 –Thevenin equivalent circuit diagram of the circuit in Figure HH.1 .....	373
Figure HH.4 – Leakage current and impulse current in relation to limits in IEC 60479 series .....	374
Figure HH.5 – Examples of circuits with equivalent impulse current and leakage current through a human body .....	375

Table 101 – Verification criterion .....	43
Table 102 – Data/message for the compatibility check test .....	47
Table 103 – Voltage threshold for emergency shutdown reaction for system B and system C .....	49
Table 104 – EV supply equipment reaction depending on the present voltage at side B condition .....	49
Table 105 – Compliance tests for protection against overvoltage at side B between DC+ and DC– .....	50
Table 106 – Test load setup for protection against overvoltage test .....	50
Table 107 – Data/messages for protection against overvoltage test .....	51
Table 108 – Overvoltage condition and verification criterion.....	51
Table 109 – Control circuit supply integrity test.....	52
Table 110 – Touch voltage under normal operation.....	69
Table 111 – Touch voltage under single fault conditions .....	69
Table 112 – Safety provisions for protection against electric shock for EV supply equipment at side B .....	72
Table 113 – Minimum protective measures .....	77
Table 114 – Pull force and torque test values for side B cable assembly anchorage .....	85
Table 115 – Touch current limits .....	88
Table 116 – Sizes of conductors of power supply cord .....	96
Table 117 – Cord strain relief pull force .....	98
Table 118 – Current ripple limit of the EV supply equipment .....	115
Table 119 – Test parameter values .....	126
Table 120 – Recommended circuit parameters of the test load .....	136
Table AA.1 – Definition of symbols of the overall circuit diagram of a system A EV supply equipment.....	141
Table AA.2 – Parameters and values of the circuit diagram for a system A EV supply equipment.....	142
Table AA.3 – Principle of fault protection .....	143
Table AA.4 – Requirements for earth leakage current fault monitoring .....	145
Table AA.5 – Error shutdown times and criteria .....	150
Table AA.6 – Action and message parameter for error shutdown triggered by the EV supply equipment.....	152
Table AA.7 – Action and message parameter for error shutdown triggered by the EV .....	152
Table AA.8 – Emergency shutdown times and criteria .....	153
Table AA.9 – Actions and criteria for emergency shutdown .....	154
Table AA.10 – System A setup of the test load for regulation of the present current at side B in CCM.....	155
Table AA.11 – System A recommended steps for regulation of the present current at side B in CCM.....	155
Table AA.12 – Specification of measuring instrument.....	157
Table AA.13 – Voltage threshold for emergency shutdown.....	157
Table AA.14 – Maximum boost current for system A EV supply equipment.....	159
Table AA.15 – FPT states of the FPT EV supply equipment .....	160
Table AA.16 – FPT control process and states of the FPT EV supply equipment.....	161
Table AA.17 – Test scenarios .....	165

Table AA.18 – Normal shutdown times and criteria .....	166
Table AA.19 – Actions and message parameters for normal shutdown.....	166
Table AA.20 – Recommended specification of target current of the EV .....	171
Table AA.21 – Requirements for the side B performance of EV supply equipment .....	171
Table AA.22 – Setup of test load for protection against under-voltage at the vehicle connector.....	176
Table AA.23 – BPT states of BPT EV supply equipment.....	176
Table AA.24 – BPT control process of BPT EV supply equipment .....	178
Table AA.25 – Selection of protection measures against over-temperature .....	183
Table AA.26 – Protection measures against over-temperature .....	183
Table BB.1 – Parameters values of the control circuit for FPT.....	186
Table BB.2 – Error shutdown times and criteria .....	192
Table BB.3 – Emergency shutdown times and criteria.....	192
Table BB.4 – EV simulator voltage ranges emergency shutdown reaction test .....	196
Table BB.5 – Setup of the test load for side B current regulation in CCM .....	201
Table BB.6 – Recommended steps for minimum side B current regulation in CCM.....	202
Table BB.7 – Recommended steps for side B voltage regulation in CVM .....	204
Table CC.1 – Vehicle couplers for system C .....	210
Table CC.2 – Component values and tolerances for configuration EE .....	212
Table CC.3 – Proximity pilot voltages.....	213
Table CC.4 – Component values and tolerances for configuration FF .....	215
Table CC.5 – Component limits for the disabled side B of the EV supply equipment .....	217
Table CC.6 – Message code mapping for sequence diagram .....	218
Table CC.7 – Example of a sequence description .....	219
Table CC.8 – Sequence description for normal startup.....	221
Table CC.9 – Sequence description for normal shutdown or pause after energy transfer by EV or EV supply equipment.....	227
Table CC.10 – Overview of error and emergency shutdown cases .....	229
Table CC.11 – Sequence description for EV supply equipment and EV initiated error shutdown .....	231
Table CC.12 – Sequence description for EV initiated error shutdown based on DIN SPEC 70121 during energy transfer .....	234
Table CC.13 – Sequence diagram an emergency shutdown executed by the EV.....	237
Table CC.14 – Sequence diagram an emergency shutdown executed by the EV supply equipment.....	240
Table CC.15 – Sequence description for pause before cable-check phase by EV supply equipment using ISO 15118-2:2014 .....	243
Table CC.16 – Sequence description for pause after pre-charge phase and before energy transfer stage by the EV supply equipment using ISO 15118-2:2014 .....	247
Table CC.17 – Sequence description for renegotiation initiated by EV or EV supply equipment using ISO 15118-2:2014 .....	253
Table CC.18 – Insulation states and EV supply equipment reaction based on the insulation resistance .....	258
Table CC.19 – Values to design the EV supply equipment during pre-charge based on Figure CC.14 .....	261

Table CC.20 – Energy transfer control modes at different communication session stage/phase .....	282
Table CC.21 – EV simulator target current and voltage .....	301
Table CC.22 – Current ripple limits .....	301
Table CC.23 – Component valued for the inrush current limit test .....	311
Table CC.24 – Current ripple limits .....	318
Table CC.25 – Test setup values to measure side B voltage regulation in CVM during pre-charge .....	323
Table CC.26 – Current ripple limits .....	332
Table CC.27 – EV simulator characteristics .....	342
Table CC.28 – Test cases for the functional check of the IMD .....	352
Table EE.1 – Test load parameters .....	356
Table FF.1 – Possible combinations for multi-side B EV supply equipment .....	361
Table HH.1 – Key(s) and exemplary values for design verification .....	371

## INTERNATIONAL ELECTROTECHNICAL COMMISSION

**ELECTRIC VEHICLE CONDUCTIVE CHARGING SYSTEM –****Part 23: DC electric vehicle supply equipment**

## FOREWORD

- 1) The International Electrotechnical Commission (IEC) is a worldwide organization for standardization comprising all national electrotechnical committees (IEC National Committees). The object of IEC is to promote international co-operation on all questions concerning standardization in the electrical and electronic fields. To this end and in addition to other activities, IEC publishes International Standards, Technical Specifications, Technical Reports, Publicly Available Specifications (PAS) and Guides (hereafter referred to as "IEC Publication(s)"). Their preparation is entrusted to technical committees; any IEC National Committee interested in the subject dealt with may participate in this preparatory work. International, governmental and non-governmental organizations liaising with the IEC also participate in this preparation. IEC collaborates closely with the International Organization for Standardization (ISO) in accordance with conditions determined by agreement between the two organizations.
- 2) The formal decisions or agreements of IEC on technical matters express, as nearly as possible, an international consensus of opinion on the relevant subjects since each technical committee has representation from all interested IEC National Committees.
- 3) IEC Publications have the form of recommendations for international use and are accepted by IEC National Committees in that sense. While all reasonable efforts are made to ensure that the technical content of IEC Publications is accurate, IEC cannot be held responsible for the way in which they are used or for any misinterpretation by any end user.
- 4) In order to promote international uniformity, IEC National Committees undertake to apply IEC Publications transparently to the maximum extent possible in their national and regional publications. Any divergence between any IEC Publication and the corresponding national or regional publication shall be clearly indicated in the latter.
- 5) IEC itself does not provide any attestation of conformity. Independent certification bodies provide conformity assessment services and, in some areas, access to IEC marks of conformity. IEC is not responsible for any services carried out by independent certification bodies.
- 6) All users should ensure that they have the latest edition of this publication.
- 7) No liability shall attach to IEC or its directors, employees, servants or agents including individual experts and members of its technical committees and IEC National Committees for any personal injury, property damage or other damage of any nature whatsoever, whether direct or indirect, or for costs (including legal fees) and expenses arising out of the publication, use of, or reliance upon, this IEC Publication or any other IEC Publications.
- 8) Attention is drawn to the Normative references cited in this publication. Use of the referenced publications is indispensable for the correct application of this publication.
- 9) IEC draws attention to the possibility that the implementation of this document may involve the use of (a) patent(s). IEC takes no position concerning the evidence, validity or applicability of any claimed patent rights in respect thereof. As of the date of publication of this document, IEC had not received notice of (a) patent(s), which may be required to implement this document. However, implementers are cautioned that this may not represent the latest information, which may be obtained from the patent database available at <https://patents.iec.ch>. IEC shall not be held responsible for identifying any or all such patent rights.

IEC 61851-23 has been prepared by IEC technical committee 69: Electric power/energy transfer systems for electrically propelled road vehicles and industrial trucks. It is an International Standard.

This second edition cancels and replaces the first edition published in 2014. This edition constitutes a technical revision.

This edition includes the following significant technical changes with respect to the previous edition:

- a) the structure has been rearranged according to IEC 61851-1:2017;
- b) electrical safety requirements in Clause 8 and Clause 12 have been revised based on the requirements in IEC 62477-1 and inspired by the hazard based safety approach of IEC 62368-1;

- c) test methods for checking conformity to the stated requirements have been mostly added; general provisions for compliance tests have been specified in Clause 102;
- d) specific requirements and/or information for the following functions have been added: energy transfer with thermal management system (101.2), bi-directional power transfer control (Annex DD), multi- side B separated EV supply equipment (Annex FF), and communication and energy transfer process (Annex GG);
- e) Annex AA (system A), Annex BB (system B) and Annex CC (system C) have been updated including additions in conjunction with b) and c). This document has been limited to be applicable to system A, system B and system C;
- f) the former Annex DD and Annex EE have been deleted. A new Annex EE, with the requirements for the artificial test load, has been added.
- g) a new informative annex for the touch current and the touch impulse current (Annex HH) has been added.

The text of this International Standard is based on the following documents:

Draft	Report on voting
69/907/FDIS	69/925/RVD

Full information on the voting for its approval can be found in the report on voting indicated in the above table.

The language used for the development of this International Standard is English.

This document was drafted in accordance with ISO/IEC Directives, Part 2, and developed in accordance with ISO/IEC Directives, Part 1 and ISO/IEC Directives, IEC Supplement, available at [www.iec.ch/members\\_experts/refdocs](http://www.iec.ch/members_experts/refdocs). The main document types developed by IEC are described in greater detail at [www.iec.ch/publications](http://www.iec.ch/publications).

This document is to be read in conjunction with IEC 61851-1:2017.

The clauses of particular requirements in this document supplement or modify the corresponding clauses in IEC 61851-1:2017. Where the text of subsequent clauses indicates an "addition" to or a "replacement" of the relevant requirement, test specification or explanation of IEC 61851-1:2017, these changes are made to the relevant text of IEC 61851-1:2017, which then becomes part of this document. Where no change is necessary, the words "This clause of IEC 61851-1:2017 is applicable" are used. The new clauses which are not included in IEC 61851-1:2017 have a clause number starting from 101, for example 3.101, 101.1, etc. The annexes of this document are numbered using double-alphabet, for example Annex AA, to avoid confusion with the annexes in IEC 61851-1:2017.

In this document, the following print types are used:

- *test specifications: italic type.*
- notes: smaller roman type.

Figures in this document use L1 and N to represent the connection of the side A of the EV supply equipment to the AC supply network or DC supply network. This is only to simplify the figures and not to impose requirements.

A list of all parts in the IEC 61851 series, published under the general title *Electric vehicle conductive charging system*, can be found on the IEC website.

The committee has decided that the contents of this document will remain unchanged until the stability date indicated on the IEC website under [webstore.iec.ch](http://webstore.iec.ch) in the data related to the specific document. At this date, the document will be

- reconfirmed,
- withdrawn, or
- revised.

**IMPORTANT – The "colour inside" logo on the cover page of this document indicates that it contains colours which are considered to be useful for the correct understanding of its contents. Users should therefore print this document using a colour printer.**

## ELECTRIC VEHICLE CONDUCTIVE CHARGING SYSTEM –

### Part 23: DC electric vehicle supply equipment

#### 1 Scope

This part of IEC 61851 applies to the EV supply equipment to provide energy transfer between the supply network and electric vehicles (EVs), with a rated maximum voltage at side A of up to 1 000 V AC or up to 1 500 V DC and a rated maximum voltage at side B up to 1 500 V DC.

This document specifies the EV supply equipment of system A, system B and system C as defined in Annex AA, Annex BB and Annex CC. Other systems are under consideration.

This document provides the requirements for bidirectional power transfer (BPT) EV supply equipment for system A, with a rated maximum voltage at side A up to 1 000 V AC or 1 500 V DC. The requirements for reverse power transfer (RPT) and BPT for system B and system C are under consideration and are not specified in this document.

Annex DD provides information about BPT.

This document does not cover all safety aspects related to maintenance.

Requirements for systems not providing simple separation or protective separation between side A and side B are under consideration.

The requirements for digital communication between EV supply equipment and the EV to control energy transfer are defined in IEC 61851-24.

Requirements for energy transfer with an automated connection device are given in IEC 61851-23-1<sup>1</sup>.

Specific requirements for EV supply equipment with multiple vehicle connectors are provided in Annex FF.

General information about energy transfer control, signalling and digital communication is provided in Annex GG.

General information on the touch current and touch impulse current is provided in Annex HH.

Requirements for EV supply equipment without current, voltage and/or power control are under consideration.

EV supply equipment in compliance with this document are not intended to provide energy transfer to a single EV with

- multiple vehicle connectors of the same EV supply equipment, or
- multiple EV supply equipment.

Requirements for such use case are under consideration.

---

<sup>1</sup> Under preparation. Stage at the time of publication: IEC AFDIS 61851-23-1:2023.

NOTE Requirements for EVs mated to an EV supply equipment are specified in ISO 17409:2020. ISO 17409 will be revised to the ISO 5474 series<sup>2</sup>.

## 2 Normative references

The following documents are referred to in the text in such a way that some or all of their content constitutes requirements of this document. For dated references, only the edition cited applies. For undated references, the latest edition of the referenced document (including any amendments) applies.

IEC 60038:2009, *IEC standard voltages*

IEC 60068-2-75:2014, *Environmental testing – Part 2-75: Tests – Test Eh: Hammer tests*

IEC 60068-2-78, *Environmental testing – Part 2-78: Tests – Test Cab: Damp heat, steady state*

IEC 60227-1:2007, *Polyvinyl chloride insulated cables of rated voltages up to and including 450/750 V – Part 1: General requirements*

IEC 60245-1:2003, *Rubber insulated cables – Rated voltages up to and including 450/750 V – Part 1: General requirements*  
IEC 60245-1:2003/AMD1:2007

IEC 60320-1, *Appliance couplers for household and similar general purposes – Part 1: General requirements*

IEC 60364-4-43:2008, *Low-voltage electrical installations – Part 4-43: Protection for safety – Protection against overcurrent*

IEC 60364-5-53:2019, *Low-voltage electrical installations – Part 5-53: Selection and erection of electrical equipment – Devices for protection for safety, isolation, switching, control and monitoring*

IEC 60364-5-54:2011, *Low-voltage electrical installations – Part 5-54: Selection and erection of electrical equipment – Earthing arrangements and protective conductors*  
IEC 60364-5-54:2011/AMD1:2021

IEC 60384-14, *Fixed capacitors for use in electronic equipment – Part 14: Sectional specification – Fixed capacitors for electromagnetic interference suppression and connection to the supply mains*

IEC 60479-1:2018, *Effects of current on human beings and livestock – Part 1: General aspects*

IEC 60479-2:2019, *Effects of current on human beings and livestock – Part 2: Special aspects*

IEC 60529, *Degrees of protection provided by enclosures (IP Code)*

IEC 60664-1:2020, *Insulation coordination for equipment within low-voltage supply systems – Part 1: Principles, requirements and tests*

IEC 60811-501, *Electric and optical fibre cables – Test methods for non-metallic materials – Part 501: Mechanical tests – Tests for determining the mechanical properties of insulating and sheathing compounds*

---

<sup>2</sup> Under preparation.

IEC 60812:2018, *Failure modes and effects analysis (FMEA and FMECA)*

IEC 60990:2016, *Methods of measurement of touch current and protective conductor current*

IEC 61008-1:2010, *Residual current operated circuit-breakers without integral overcurrent protection for household and similar uses (RCCBs) – Part 1: General rules*

IEC 61008-1:2010/AMD1:2012

IEC 61008-1:2010/AMD2:2013

IEC 61009-1:2009, *Residual current operated circuit-breakers with integral overcurrent protection for household and similar uses (RCBOs) – Part 1: General rules*

IEC 61009-1:2009/AMD1:2012

IEC 61009-1:2009/AMD2:2013

IEC 60947-2:2016, *Low-voltage switchgear and controlgear – Part 2: Circuit-breakers*

IEC 60947-2:2016/AMD1:2019

IEC 61140:2016, *Protection against electric shock – Common aspects for installation and equipment*

IEC 61439-1:2020, *Low-voltage switchgear and controlgear assemblies – Part 1: General rules*

IEC 61439-7:2022, *Low-voltage switchgear and controlgear assemblies – Part 7: Assemblies for specific applications such as marinas, camping sites, market squares, electric vehicle charging stations*

IEC 61540:1997, *Electrical accessories – Portable residual current devices without integral overcurrent protection for household and similar use (PRCDs)*

IEC 61540:1997/AMD1:1998

IEC 61557-8:2014, *Electrical safety in low voltage distribution systems up to 1 000 V a.c. and 1 500 V DC – Equipment for testing, measuring or monitoring of protective measures – Part 8: Insulation monitoring devices for IT systems*

IEC 61558-1:2017, *Safety of transformers, reactors, power supply units and combinations thereof – Part 1: General requirements and tests*

IEC 61558-2-4:2021, *Safety of transformers, reactors, power supply units and combinations thereof – Part 2-4: Particular requirements and tests for isolating transformers and power supply units incorporating isolating transformers for general applications*

IEC 61643 (all parts), *Low-voltage surge protective devices*

IEC 61643-11, *Low-voltage surge protective devices – Part 11: Surge protective devices connected to low-voltage power systems – Requirements and test methods*

IEC 61643-21, *Low voltage surge protective devices – Part 21: Surge protective devices connected to telecommunications and signalling networks – Performance requirements and testing methods*

IEC 61851-1:2017, *Electric vehicle conductive charging system – Part 1: General requirements*

IEC 61851-21-2:2018, *Electric vehicle conductive charging system – Part 21-2: Electric vehicle requirements for conductive connection to an AC/DC supply – EMC requirements for off-board electric vehicle charging systems*

IEC 61851-24:2023, *Electric vehicle conductive charging system – Part 24: Digital communication between a DC EV charging station and an electric vehicle for control of DC charging*

IEC 62196-1:2022, *Plugs, socket-outlets, vehicle connectors and vehicle inlets – Conductive charging of electric vehicles – Part 1: General requirements*

IEC 62196-3:2022, *Plugs, socket-outlets, vehicle connectors and vehicle inlets – Conductive charging of electric vehicles – Part 3: Dimensional compatibility and interchangeability requirements for DC and AC/DC pin and contact-tube vehicle couplers*

IEC TS 62196-3-1:2020, *Plugs, socket-outlets, vehicle connectors and vehicle inlets – Conductive charging of electric vehicles – Part 3-1: Vehicle connector, vehicle inlet and cable assembly for DC charging intended to be used with a thermal management system*

IEC 62368-1:2023, *Audio/video, information and communication technology equipment – Part 1: Safety requirements*

IEC 62423:2009, *Type F and type B residual current operated circuit-breakers with and without integral overcurrent protection for household and similar uses*

IEC 62262, *Degrees of protection provided by enclosures for electrical equipment against external mechanical impacts (IK code)*

IEC 62477-1:2022, *Safety requirements for power electronic converter systems and equipment – Part 1: General*

IEC 62893-4-1:2020, *Charging cables for electric vehicles of rated voltages up to and including 0,6/1 kV – Part 4-1: Cables for DC charging according to mode 4 of IEC 61851-1 – DC charging without use of a thermal management system*

IEC Guide 115, *Application of measurement uncertainty to conformity assessment activities in the electrotechnical sector*

ISO 2719:2016, *Determination of flash point – Pensky-Martens closed cup method*

ISO 6469-3:2018<sup>3</sup>, *Electrically propelled road vehicles – Safety specifications – Part 3: Electrical safety*

ISO 7000, *Graphical symbols for use on equipment*, available at <http://www.graphical-symbols.info/equipment>

ISO 7010, *Graphical symbols – Safety colours and safety signs – Registered safety signs*, available at <https://www.iso.org/obp>

ISO 15118-2:2014, *Road vehicles – Vehicle-to-grid communication interface – Part 2: Network and application protocol requirements*

ISO 15118-3, *Road vehicles – Vehicle to grid communication interface – Part 3: Physical and data link layer requirements*

ISO 17409:2020, *Electrically propelled road vehicles – Conductive power transfer – Safety requirements*

---

<sup>3</sup> This publication has been withdrawn. A new edition of ISO 6469-3 (4<sup>th</sup> edition) came out in 2021.

DIN SPEC 70121:2014, *Electromobility – Digital communication between a DC EV charging station and an electric vehicle for control of DC charging in the combined charging system*

OECD 301 B, *OECD Guideline for testing of chemicals*

### 3 Terms and definitions

For the purposes of this document, the terms and definitions given in IEC 61851-1:2017 apply, except as follows.

ISO and IEC maintain terminological databases for use in standardization at the following addresses:

- IEC Electropedia: available at <http://www.electropedia.org/>
- ISO Online browsing platform: available at <http://www.iso.org/obp>

*Addition:*

NOTE The definitions included in this document are those having general application herein. Definitions applying to isolating transformers, safety isolating transformers, switch mode power supplies, and their construction are included in IEC 61558-1.

#### 3.1 Electric supply equipment

*Additional terms and definitions:*

##### 3.1.101

##### **separated EV supply equipment**

EV supply equipment where the side B circuit is separated from all other circuits

Note 1 to entry: See Clause 8 for the requirements of separation between each circuit.

##### 3.1.102

##### **non-separated EV supply equipment**

EV supply equipment where the side B circuit is not separated from one or more other circuits

Note 1 to entry: See Clause 8 for the requirements of separation between each circuit.

##### 3.1.103

##### **energy transfer**

##### **power transfer**

DEPRECATED: charging

delivery of energy, in either direction, between parts of a system

Note 1 to entry: The direction of the energy transfer is defined by the application.

#### 3.2 Insulation

##### 3.2.1

##### **basic insulation**

*Addition:*

Note 1 to entry: This concept does not apply to insulation used exclusively for functional purposes.

##### 3.2.8

##### **insulation**

*Replacement:*

all the materials and parts used to insulate conductive elements of a device

[SOURCE: IEC 60050-151:2001, 151-15-41]

*Additional terms and definitions:*

### **3.2.101**

#### **asymmetrical insulation faults asymmetrical faults**

defect in the insulation of an electric installation or equipment creating a resistive path to protective conductor having different resistances from the live conductors to protective conductor

[SOURCE: IEC 61557-8:2014, 3.1.20, modification – Words "phase conductors" replaced with "live conductors", and "earth" with "protective conductor".]

### **3.2.102**

#### **dead, adj**

de-energized, adj

qualifies a conductive part when it is not energized

[SOURCE: IEC 60050-151:2001, 151-15-59, modified – Term "de-energized" added.]

### **3.2.103**

#### **live, adj**

energized, adj

qualifies a conductive part having an electric potential difference with respect to a relevant reference

Note 1 to entry: The reference potential is usually the Earth or an equipotential frame.

Note 2 to entry: A live part may be temporarily dead when it is not energized. A neutral conductor is considered as live but earthing conductors are not.

Note 3 to entry: A part is energized (live) when it is electrically connected to a source of electric energy. It can also be energized (live) when it is electrically charged and/or under the influence of an electric or magnetic field.

Note 4 to entry: See IEC 60050-651:2014, 651-21-08.

[SOURCE: IEC 60050-151:2001, 151-15-58, modified – Term "live" added, as well as Notes 2 and 3 to entry.]

### **3.2.104**

#### **leakage current monitoring device**

DEPRECATED: leakage measuring device

passive electrical device for monitoring insulation resistance of separated DC system by measuring leakage current between live parts and exposed conductive part or the protective conductor

### **3.2.105**

#### **enhanced protective provision**

protective provision having a reliability of protection not less than that provided by two independent protective provisions

[SOURCE: IEC 60050-195:2021, 195-06-27]

### **3.2.106**

#### **fault protection**

protection against electric shock under single-fault conditions

[SOURCE: IEC 60050-195:2021, 195-06-02]

**3.2.107****insulation**

set of properties which characterize the ability of insulation to provide its function

Note 1 to entry: Examples of relevant properties are: resistance, breakdown voltage.

[SOURCE: IEC 60050-151:2001, 151-15-42]

**3.2.108****insulation monitoring device**

IMD

device which permanently monitors the insulation resistance to protective conductor of separated AC IT systems, AC IT systems with galvanically connected DC circuits having nominal voltages less than or equal to 1 000 V AC, as well as monitoring the insulation resistance of a separated DC IT systems with voltages less than or equal to 1 500 V DC, independent from the method of measuring

[SOURCE: IEC 61557-8:2014, 3.1.14, modified – Word "earth" replaced with "protective conductor" and "unearthed" with "separated".]

**3.2.109****live part**

<in electrical installations and equipment> conductive part intended to be energized under normal operating conditions, including the neutral conductor and mid-point conductor, but excluding the PEN conductor, PEM conductor and PEL conductor

Note 1 to entry: This concept does not necessarily imply a risk of electric shock.

[SOURCE: IEC 60050-195:2021, 195-02-19, modified – Note to entry added.]

**3.2.110****PELV system**

electric system in which the voltage cannot be more than the value of extra low voltage:

- under normal conditions; and
- under single fault conditions, except earth faults in other electric circuits

Note 1 to entry: PELV is the abbreviation for protective extra low voltage.

[SOURCE: IEC 60050-826:2022, 826-12-32]

**3.2.111****protective conductor**

PE

conductor provided for purposes of safety, for example, protection against electric shock

EXAMPLE Protective bonding conductor, protective earthing conductor and an earthing conductor when used for protection against electric shock.

[SOURCE: IEC 60050-826:2022, 826-13-22, modified – Word "electrical" deleted and example added in the definition. The Note to entry 1 has been deleted, and the example added.]

**3.2.112****protective-equipotential-bonding**

equipotential bonding for purposes of safety

EXAMPLE Protection against electric shock.

[SOURCE: IEC 60050-826:2022, 826-13-20, modified – Word "electrical" deleted in the definition and example added.]

**3.2.113****protective screening**

protective shielding <electrically> US

<electrically> separation of electric circuits and/or conductors from hazardous-live-parts by an electrically protective screen connected to the protective equipotential bonding system and intended to provide protection against electric shock

[SOURCE: IEC 60050-195:2021, 195-06-18]

**3.2.114****protective separation**

<electrically> separation of one electric circuit from another by means of:

- double insulation, or
- basic insulation and electrically protective screening, or
- reinforced insulation

[SOURCE: IEC 60050-826:2022, 826-12-29]

**3.2.115****rated DC withstand voltage**

value of a DC withstand voltage declared by the manufacturer to characterize the isolating behaviour of a surge protective device (SPD)

[SOURCE: IEC 62561-3:2017, 3.8, modified – Words "an ISG" replaced with "a surge protective device (SPD)".]

**3.2.116****single fault condition**

condition in which there is a fault of a single protective provision that is not an enhanced protective provision

Note 1 to entry: If a single fault condition results in one or more other fault conditions, all those are considered as one single fault condition.

**3.2.117****startle reaction**

physiological reaction due to a minimum derived value of touch voltage for a population for which a current flowing through the body is just enough to cause involuntary muscular contraction to the person through which it is flowing

**3.2.118****touch impulse current**

impulse current, or the corresponding charge or energy, dissipated in a human body or through livestock when it touches either a live part, or a hazardous-live-part or an exposed-conductive part of an installation or of equipment under certain conditions

Note 1 to entry: The impulse current has an RMS magnitude and duration associated with it in accordance with IEC 60479-2:2019, Clause 11.

Note 2 to entry: Capacitive coupling between side B live parts and protective conductor usually results from Y-capacitance, used for electromagnetic compatibility reasons, or from parasitic capacitive coupling.

**3.2.119****touch voltage**

<effective> voltage between conductive parts when touched simultaneously by a person or an animal

Note 1 to entry: The value of the effective touch voltage may be appreciably influenced by the impedance of the person or the animal in electric contact with these conductive parts.

[SOURCE: IEC 60050-826:2022, 826-11-05, modified – Words "a human being or a livestock" replaced with "a person or an animal, and note to entry added.]

### **3.2.120**

#### **SELV system**

electric system in which the voltage cannot be more than the value of extra-low voltage:

- under normal conditions; and
- under single fault conditions, including earth faults in other electric circuits

Note 1 to entry: SELV is the abbreviation for safety extra-low voltage.

[SOURCE: IEC 60050-195:2021, 195-06-28]

### **3.2.121**

#### **surge protective device**

#### **SPD**

device that is intended to protect the electrical apparatus from transient overvoltages and to divert surge currents

Note 1 to entry: A surge protective device contains at least one non-linear component.

[SOURCE: IEC 60050-614:2016, 614-03-48]

### **3.2.122**

#### **symmetrical insulation fault**

#### **symmetrical fault**

defect in the insulation of an electric installation or equipment creating a resistive path to protective conductor having approximately the same resistance from all live conductors to protective conductor

[SOURCE: IEC 61557-8:2014, 3.1.19, modified – Words “symmetrical fault” added in the term and “phase” is replaced by “live”]

### **3.2.123**

#### **Y-capacitance**

total capacitance bridging the insulation barriers of the DC+ and DC– of side B to other circuits and protective conductor

Note 1 to entry: The capacitors are of a type suitable for use in situations where failure of the capacitor could lead to electric shock.

Note 2 to entry: The total capacitance is commonly distributed equally over the live conductors.

Note 3 to entry: For more information, see IEC 60384-14.

## **3.3 Functions**

### **3.3.1**

#### **control pilot conductor**

*Replacement:*

#### **control pilot conductor**

#### **CP**

conductor incorporated in a cable assembly, which, together with the protective conductor, is part of the control pilot circuit

### 3.3.5 proximity function

*Replacement:*

#### proximity function PP

DEPRECATED: proximity pilot

electrical or mechanical means to indicate the insertion state of the vehicle connector in the vehicle inlet of the EV and/or to indicate the insertion state of the EV plug in the EV socket-outlet of the EV supply equipment

Note 1 to entry: The acronym PP is based on "plug present".

*Additional terms and definitions:*

### 3.3.101 coupling session

DEPRECATED: charging session

DEPRECATED: charge session

DEPRECATED: supply session

session that starts when the vehicle connector is mated to the vehicle inlet and terminates when the vehicle connector is un-mated from the vehicle inlet

Note 1 to entry: A coupling session can have zero, one or multiple communication sessions.

Note 2 to entry: See Figure 101.

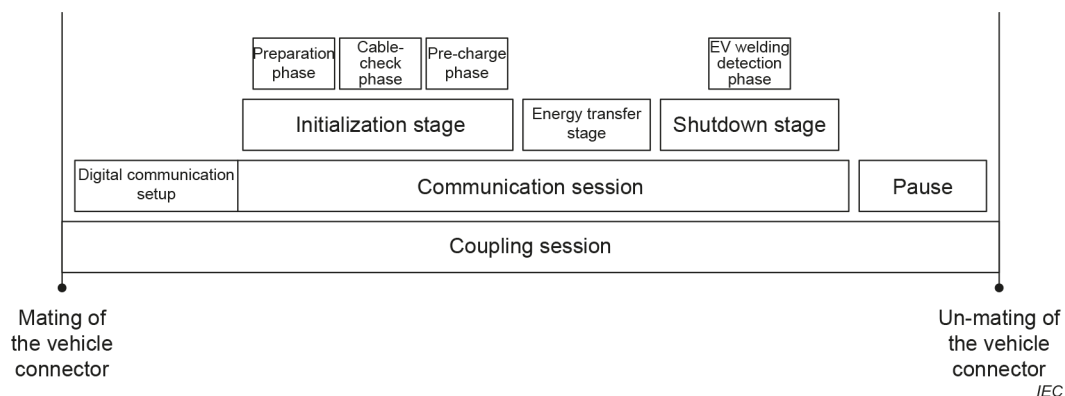

NOTE 1 Figure 101 shows the naming of the sessions, stages and phases. This is not a timing or sequence diagram. Sequence diagrams are specified for each system in the respective annex.

NOTE 2 Details about the digital communication setup are specified in IEC 61851-24.

**Figure 101 – Example of a coupling session**

### 3.3.102 communication session

session that includes the initialization stage, energy transfer stage, and the shutdown stage

Note 1 to entry: Multiple consecutive communication sessions can occur in a coupling session.

Note 2 to entry: A communication session can include only the initialization stage and shutdown stage, if the EV supply equipment is unable to perform energy transfer.

### 3.3.103 pause

period of time between communication sessions where the EV supply equipment does not perform energy transfer

Note 1 to entry: The EV supply equipment and/or the EV may enable sleep mode during a pause.

### **3.3.104**

#### **sleep mode**

state of a device or equipment to reduce energy consumption

### **3.3.105**

#### **initialization stage**

stage at the beginning of a communication session to set, check and confirm parameters for the purpose of energy transfer

Note 1 to entry: An initialization stage can be triggered by the user, wake-up/re-initialization triggered by the EV or EV supply equipment after sleep, a pause or a power outage.

### **3.3.106**

#### **energy transfer stage**

stage to perform energy transfer between the EV and the EV supply equipment

### **3.3.107**

#### **shutdown stage**

stage at the end of a communication session to reach a safe state

EXAMPLE Normal shutdown, error shutdown and emergency shutdown.

### **3.3.108**

#### **preparation phase**

phase during which an EV and EV supply equipment interact to set, check and confirm parameters and working conditions

EXAMPLE Perform compatibility check, verification of smart charging conditions.

### **3.3.109**

#### **cable-check phase**

phase to check if the side B can safely become live, based on the parameters exchanged by basic signalling and digital communication

### **3.3.110**

#### **pre-charge phase**

phase for the EV supply equipment or EV to limit the inrush current at side B

### **3.3.111**

#### **EV welding detection phase**

phase for the EV to check if the EV disconnection device is not welded

Note 1 to entry: EV welding detection phase is optional.

### **3.3.112**

#### **normal shutdown**

termination of the energy transfer initiated by the user, by the EV or by the EV supply equipment

### **3.3.113**

#### **error shutdown**

termination of the energy transfer caused by a failure detected by the EV supply equipment or the EV

### **3.3.114**

#### **emergency shutdown**

urgent termination of the energy transfer caused by a failure detected by the EV supply equipment or the EV

Note 1 to entry: An emergency shutdown may be performed by disconnecting the EV supply equipment from the supply network.

**3.3.115****controlled current mode****CCM**

DEPRECATED: CCC

DEPRECATED: CCCM

<EV supply equipment> control mode of the EV supply equipment to control the present current at side B according to the target current of the EV supply equipment

**3.3.116****controlled voltage mode****CVM**

DEPRECATED: CVC

DEPRECATED: CVCM

<EV supply equipment> control mode of the EV supply equipment to control the present voltage at side B according to the target voltage of the EV supply equipment

**3.3.117****controlled power mode****CPM**

DEPRECATED: CPCM

<EV supply equipment> control mode of the EV supply equipment to control the present power at side B according to the target power of the EV supply equipment

**3.3.118****thermal exchange**

function dissipating thermal energy from the thermal transport

[SOURCE: IEC TS 62196-3-1:2020, 3.105, modified – Words "method for cooling and" replaced with "function".]

**3.3.119****thermal exchange device**

means for dissipating thermal energy from the thermal transport

[SOURCE: IEC TS 62196-3-1:2020, 3.106, modified – Words "cooling and" removed.]

**3.3.120****thermal sensing**

function to provide a signal or measurement for obtaining temperature data of cable assemblies or parts thereof

[SOURCE: IEC TS 62196-3-1:2020, 3.101, modified – Word "method" replaced with "function to provide a signal or measurement", and "accessories" removed.]

**3.3.121****thermal sensing device**

means for thermal sensing

[SOURCE: IEC TS 62196-3-1:2020, 3.102, modified – Words "providing temperature data of accessories, cable assemblies or parts thereof" replaced with "thermal sensing".]

**3.3.122****thermal transport**

function for managing the thermal energy dissipation of cable assemblies or parts thereof by heat transfer

[SOURCE: IEC TS 62196-3-1:2020, 3.103, modified – Word "method" replaced with "function", "heat dissipation of accessories" replaced with "thermal energy dissipation of", and "independent of changing the current" replaced with "by heat transfer".]

### **3.3.123**

#### **thermal transport device**

means for managing thermal energy dissipation of cable assemblies or parts thereof

[SOURCE: IEC TS 62196-3-1:2020, 3.104, modified – Words "the heat dissipation of accessories" replaced with "thermal energy dissipation of", and "independent of changing the current" removed.]

### **3.3.124**

#### **forward power transfer**

forward energy transfer

FPT

DEPRECATED: charging

distribution of electricity from the supply network to an EV

### **3.3.125**

#### **reverse power transfer**

reverse energy transfer

RPT

distribution of electricity from an EV to the supply network or to a load

Note 1 to entry: Household appliances are covered by the IEC 60335 series.

Note 2 to entry: Load according to IEC 60050-151:2001, 151-15-15, means a device intended to absorb power supplied by another device or an electric power system.

### **3.3.126**

#### **bidirectional power transfer**

bidirectional energy transfer

BPT

DEPRECATED: bi-directional power transfer

combination of forward power transfer (FPT) and reverse power transfer (RPT)

Note 1 to entry: BPT can only be FPT, RPT or (free) floating between FPT and RPT, depending on the agreement with or request of DSO/CSO.

## **3.4 Vehicle**

### **3.4.1**

#### **electric vehicle**

**EV**

**(electric road vehicle)**

*Replacement:*

#### **electrically propelled vehicle**

**EV**

vehicle with one or more electric drive(s) for vehicle propulsion

[SOURCE: ISO 6469-3:2021, 3.15]

### **3.4.3 rechargeable energy storage system RESS**

*Replacement:*

#### **battery system**

DEPRECATED: RESS

DEPRECATED: EV battery

DEPRECATED: vehicle battery

DEPRECATED: vehicle/traction battery

DEPRECATED: traction battery

<EV> energy storage device that includes cells, cell assemblies or battery pack(s) as well as electrical circuits and electronics

Note 1 to entry: Battery system components can also be distributed in different devices (battery packs) within the vehicle.

Note 2 to entry: Examples of electronics are the battery control unit and contactors.

*Additional terms and definitions:*

#### **3.4.101**

##### **EV disconnection device**

dedicated disconnect or equivalent device(s) for energy transfer located in the vehicle power supply circuit between the vehicle inlet and the EV battery system

Note 1 to entry: The EV disconnection device is controlled during the communication session in accordance with the system specific sequence diagram between the EV supply equipment and the EV.

#### **3.4.102**

##### **vehicle power supply circuit**

voltage class B electric circuit which includes all parts that are conductively connected to the vehicle inlet that are mounted on the EV and that is energized during the energy transfer

Note 1 to entry: The definition is different from that in ISO 17409:2020. In the ISO 5474 series, the vehicle power supply circuit does not include anything off-board of the EV.

[SOURCE: ISO 5474-1:—, 3.2.21, modified – Definition reformulated and Note 1 to entry added.]

## **3.5 Cords, cables and connection means**

### **3.5.13**

*Replacement:*

#### **vehicle connector**

electric vehicle connector

part integral with, or intended to be attached to, one flexible cable

[SOURCE: IEC 62196-1:2022, 3.56]

### **3.5.14**

#### **vehicle inlet**

##### **electric vehicle inlet**

*Replacement:*

#### **vehicle inlet**

electric vehicle inlet

part incorporated in, or fixed to, the EV

Note 1 to entry: The resulting assembly when a vehicle connector is inserted into a vehicle inlet is called a "vehicle coupler".

[SOURCE: IEC 62196-1:2022, 3.57, modified – Words "electric vehicle" replaced with "EV".]

*Additional terms and definitions:*

**3.5.101**

**cable assembly**

<side B> assembly consisting of flexible cable fitted with a vehicle connector, and that is used to connect the EV to the EV supply equipment

**3.6 Service and usage**

**3.6.10**

**user**

*Replacement:*

person who uses or benefits from, or uses and benefits from, devices, systems or services

EXAMPLE Device or system may be HMI, EV or EV supply equipment; service may be energy transfer between EV and EV supply equipment.

[SOURCE: IEC 60050-871:2018, 871-02-05, modified – Term "active assisted living user" removed, abbreviated term "AAL" removed in the entry, and example added.]

**3.6.111**

**ordinary person**

person who is neither a skilled person nor an instructed person

Note 1 to entry: Ordinary persons include users of the EV supply equipment, persons who may have access to the EV supply equipment, and who may be in the vicinity of the EV supply equipment. Under normal operating conditions, ordinary persons should not be exposed to energy sources causing startle reaction, pain or injury.

[SOURCE: IEC 60050-826:2022, 826-18-03, modified – Note 1 to entry added.]

**3.6.112**

**skilled person**

<electrically> person with relevant education and experience to perceive risks and to avoid hazards which electricity can create

[SOURCE: IEC 60050-826:2022, 826-18-01, modified – Second preferred term "electrically skilled person" removed.]

**3.6.113**

**instructed person**

<electrically> person adequately advised or supervised by electrically skilled persons to perceive risks and to avoid hazards which electricity can create

[SOURCE: IEC 60050-826:2021, 826-18-02, modified – Second preferred term "electrically instructed person" removed.]

**3.6.114**

**human machine interface**

HMI

DEPRECATED: user interface

device/means that allows user interaction, interface between operator, operating staff or end user and the instrumentation and computer systems connected to the EVCC/EMS

EXAMPLE Display or user communication system, mobile phone interface.

Note 1 to entry: The HMI can be connected to an EVCC, an energy management system or another controller depending on the communication system used.

### 3.7 General terms

*Additional terms and definitions:*

#### 3.7.101

##### **fire enclosure**

enclosure intended as protection against the spread of fire from within the enclosure to outside the enclosure

Note 1 to entry: Some standards use the term "safeguard" instead of "protection".

[SOURCE: IEC 60050-903:2014, 903-04-10]

#### 3.7.102

##### **side A**

supply network side

DEPRECATED: input

DEPRECATED: primary circuit

side of the EV supply equipment connected to the supply network

#### 3.7.103

##### **side B**

EV side

DEPRECATED: output

DEPRECATED: DC output circuit

DEPRECATED: secondary circuit

side of the EV supply equipment connected to the EV

#### 3.7.104

##### **side B circuit**

electrical circuit at side B which includes all parts of the EV supply equipment that are conductively connected to the DC+ or DC– of the vehicle connector

#### 3.7.105

##### **supply network**

system for the distribution of electricity connected to side A

Note 1 to entry: The following terms are also used frequently in this context: system for distribution of electricity to the public, public distribution network, public network, prosumer's electrical installation (PEI), distributed energy resources (DER), battery bank, PV installation, generator, mains or electric grid, etc.

#### 3.7.106

##### **load dump**

spontaneous disconnection, during the energy transfer stage, of the battery system or other loads connected to side B

Note 1 to entry: Load dump can be caused by the load for the purpose of protection, or by a fault.

#### 3.7.107

##### **power electronics converter**

PEC

DEPRECATED: power electronic converter system

device or part thereof for the purpose of electronic power conversion

Note 1 to entry: PEC can include signalling, measurement, control circuitries and other parts, if essential for the power conversion function.

**3.7.108****ripple**

<current or voltage> set of unwanted periodic deviations with respect to the average value of the measured or supplied quantity

EXAMPLE Ripple occurring at frequencies which can be related to that of the supply network, or of some other definite source, such as a power-electronics converters (PECs).

Note 1 to entry: Ripple is determined under specified conditions and is a part of periodic and/or random deviation (PARD) – IEC 60050-312:2001, 312-07-01.

[SOURCE: IEC 60050-312:2001, 312-07-02, modified – Example added, which comes from the definition, and note clarified.]

**3.7.109****transient, adj**

pertaining to a phenomenon or quantity which passes from one steady state to another consecutive steady state

Note 1 to entry: The term "transient" is also used as a noun to mean a transient phenomenon or quantity.

[SOURCE: IEC 60050-312:2009, 103-05-02]

**3.7.110****transient, noun**

<current or voltage> phenomenon or quantity which varies between two consecutive steady states during a time interval short compared to the timescale of interest

[SOURCE: IEC 60050-702:2019, 702-07-781]

**3.7.111****applicable maximum current**

upper limit of the current that is used during the energy transfer stage, and which may dynamically be changed throughout the energy transfer stage

Note 1 to entry: On side B, there is an applicable maximum current of the EV supply equipment as well as an applicable maximum current of the EV.

Note 2 to entry: On side B, this limit may be changed by digital communication.

**3.7.112****applicable maximum power**

upper limit of the power that is used during the energy transfer stage, and which may dynamically be changed throughout the energy transfer stage

Note 1 to entry: On side B, there is an applicable maximum power of the EV supply equipment as well as an applicable maximum power of the EV.

Note 2 to entry: On side B, this limit may be changed by digital communication.

**3.7.113****applicable maximum voltage**

upper limit of the voltage between live parts that is used during the energy transfer stage, and which may dynamically be changed throughout the energy transfer stage

Note 1 to entry: On side B, there is an applicable maximum voltage of the EV supply equipment as well as an applicable maximum voltage of the EV.

Note 2 to entry: On side B, this limit may be changed by digital communication.

Note 3 to entry: For DC, the voltage between DC+ and DC-. For AC, the voltage between L1, L2, L3 and N as needed by the configuration.

**3.7.114****applicable minimum current**

lower limit of the current that is used during the energy transfer stage, and which may dynamically be changed throughout the energy transfer stage

Note 1 to entry: On side B, there is an applicable minimum current of the EV supply equipment as well as an applicable minimum current of the EV.

Note 2 to entry: On side B, this limit may be changed by digital communication.

**3.7.115****applicable minimum power**

lower limit of the power that is used during the energy transfer stage, and which may dynamically be changed throughout the energy transfer stage

Note 1 to entry: On side B, there is an applicable minimum power of the EV supply equipment as well as an applicable minimum power of the EV.

Note 2 to entry: On side B, this limit may be changed by digital communication.

**3.7.116****applicable minimum voltage**

lower limit of the voltage between live parts that is used during the energy transfer stage, and which may dynamically be changed throughout energy transfer

Note 1 to entry: On side B, there is an applicable minimum voltage of the EV supply equipment as well as an applicable minimum voltage of the EV.

Note 2 to entry: On side B, this limit may be changed by digital communication.

Note 3 to entry: For DC, the voltage between DC+ and DC-. For AC the voltage between L1, L2, L3 and N as needed by the configuration.

**3.7.117****measured current**

result of a measurement of the present current measured under certain measurement conditions

Note 1 to entry: Measurement conditions can be applying a filter, having an uncertainty in measurement, etc.

**3.7.118****measured voltage**

result of a measurement of the present voltage measured under certain measurement conditions

Note 1 to entry: Measurement conditions can be applying a filter, having an uncertainty in measurement, etc.

**3.7.119****measured power**

result of a measurement of the present power measured under certain measurement conditions

Note 1 to entry: Measurement conditions can be applying a filter, having an uncertainty in measurement, etc.

**3.7.120****negotiated maximum current**

<at side B> upper limit of the current operating range agreed upon during the initialization stage between the EV supply equipment and the EV

Note 1 to entry: At side B, this limit is negotiated between the EV supply equipment and the EV by digital communication and can be changed in a new initialization stage.

**3.7.121****negotiated maximum power**

<at side B> upper limit of the power operating range agreed upon during the initialization stage between the EV supply equipment and the EV

Note 1 to entry: At side B, this limit is negotiated between the EV supply equipment and the EV by digital communication and can be changed in a new initialization stage.

**3.7.122****negotiated maximum voltage**

<at side B> upper limit of the voltage operating range between live parts agreed upon during the initialization stage between the EV supply equipment and the EV

Note 1 to entry: At side B, this limit is negotiated between the EV supply equipment and the EV by digital communication and can be changed in a new initialization stage.

**3.7.123****negotiated minimum current**

<at side B> lower limit of the current operating range agreed upon during the initialization stage between the EV supply equipment and the EV

Note 1 to entry: At side B, this limit is negotiated between the EV supply equipment and the EV by digital communication, and can be changed in a new initialization stage.

**3.7.124****negotiated minimum power**

<at side B> lower limit of the power operating range agreed upon during the initialization stage between the EV supply equipment and the EV

Note 1 to entry: At side B, this limit is negotiated between the EV supply equipment and the EV by digital communication, and can be changed in a new initialization stage.

**3.7.125****negotiated minimum voltage**

<at side B> lower limit of the voltage operating range between live parts agreed upon during the initialization stage between the EV supply equipment and the EV

Note 1 to entry: At side B, this limit is negotiated between the EV supply equipment and the EV by digital communication, and can be changed in a new initialization stage.

**3.7.126****present current**

instantaneous physical value of the current

Note 1 to entry: The present current is the instantaneous value of the current which would be acquired by an ideal/perfect measurement device in a single sample without any filtering and without any measurement tolerance/error.

**3.7.127****present voltage**

instantaneous physical value of the voltage

Note 1 to entry: The present voltage is the instantaneous value of the voltage which would be acquired by an ideal/perfect measurement device in a single sample without any filtering and without any measurement tolerance/error.

**3.7.128****present power**

instantaneous physical value of the power

Note 1 to entry: The present power is the instantaneous value of the power which would be acquired by an ideal/perfect measurement device in a single sample without any filtering and without any measurement tolerance/error.

**3.7.129****rated boost current**

<side B> upper limit of the current specified by the manufacturer up to which the EV supply equipment has been designed to operate for a limited period of time

Note 1 to entry: The rated boost current is more than or equal to the rated continuous current.

Note 2 to entry: The rated boost current of the side B cable assembly is under consideration in IEC 62196-1, IEC 62196-3 and IEC 62196-3-1. For more information, see 101.3.

**3.7.130****rated current**

<side A> current under normal operating conditions assigned by the manufacturer

**3.7.131****rated continuous current**

<side B> upper limit of the current specified by the manufacturer up to which the EV supply equipment has been designed to operate continuously

Note 1 to entry: In the IEC 62196 (published before 2023) series, the rated continuous current is called "rated current".

**3.7.132****rated boost power**

<side B> upper limit of the power specified by the manufacturer up to which the EV supply equipment has been designed to operate for a limited period of time

Note 1 to entry: The rated boost power is greater than or equal to the rated continuous power.

**3.7.133****rated continuous power**

<side B> upper limit of the power specified by the manufacturer up to which the EV supply equipment has been designed to operate continuously

**3.7.134****rated maximum power**

<side A> upper limit of the power specified by the manufacturer up to which the EV supply equipment has been designed to operate

**3.7.135****rated maximum voltage**

<side A or side B> upper limit of the voltage between live parts specified by the manufacturer up to which the EV supply equipment has been designed to operate

**3.7.136****rated minimum current**

<side A or side B> lower limit of the current specified by the manufacturer down to which the EV supply equipment has been designed to operate

**3.7.137****rated minimum power**

<side A or side B> lower limit of the power specified by the manufacturer down to which the EV supply equipment has been designed to operate

**3.7.138****rated minimum voltage**

<side A or side B> lower limit of the voltage between live parts specified by the manufacturer down to which the EV supply equipment has been designed to operate

**3.7.139**

**target current**

<EV> requested current to the EV supply equipment, which may dynamically be changed by digital communication

Note 1 to entry: On side B, this target current is requested by the EV only.

**3.7.140**

**target power**

<EV> requested power to the EV supply equipment, which may dynamically be changed by digital communication

Note 1 to entry: On side B, this target power is requested by the EV only.

**3.7.141**

**target voltage**

<EV> requested voltage to the EV supply equipment, which may dynamically be changed by digital communication

Note 1 to entry: On side B, this target voltage is requested by the EV only.

**3.7.142**

**target current**

<EV supply equipment> value of current that the EV supply equipment attempts to reach

Note 1 to entry: The target current of the EV supply equipment at side B is dynamically calculated based on certain values, for example, the target values of the EV, the negotiated limits of side B or applicable limits of side B or of side A.

Note 2 to entry: The target current of the EV supply equipment at side B is not communicated to the EV by digital communication.

Note 3 to entry: The target current of the EV supply equipment at side A is following the grid code of the DSO.

**3.7.143**

**target power**

<EV supply equipment> value of power that the EV supply equipment attempts to reach

Note 1 to entry: The side B target power of the EV supply equipment is dynamically calculated based on certain values, for example, the target values of the EV, the negotiated limits of side B or applicable limits of side B or of side A.

Note 2 to entry: The side B target power of the EV supply equipment is not communicated to the EV by digital communication.

Note 3 to entry: The side A target power of the EV supply equipment is following the grid code of the DSO.

**3.7.144**

**target voltage**

<EV supply equipment> value of voltage that the EV supply equipment attempts to reach

Note 1 to entry: The side B target voltage of the EV supply equipment is dynamically calculated based on certain values, for example, the target values of the EV, the negotiated limits of side B or applicable limits of side B or of side A.

Note 2 to entry: The side B target voltage of the EV supply equipment is not communicated to the EV by digital communication.

Note 3 to entry: The side A target voltage of the EV supply equipment is following the grid code of the DSO.

**3.7.145****auxiliary circuit**

auxiliary power supply

classification of an electric component or circuit with a maximum working voltage of  $\leq 30$  V AC (RMS) or  $\leq 60$  V DC, respectively

Note 1 to entry: Circuit(s) for signalling, digital communication, and for the management and control of energy transfer.

**3.7.146****EV communication controller**

EVCC

DEPRECATED: vehicle charging control function

DEPRECATED: VCCF

DEPRECATED: vehicle charging/discharging control function

DEPRECATED: VCDCF

embedded system, within the EV, which implements the communication between the EV and the SECC in order to support specific functions

Note 1 to entry: Such specific functions could be, for example, controlling input and output channels, encryption, or data transfer between EV and SECC.

**3.7.147****supply equipment communication controller**

SECC

entity which implements the communication to one or multiple EVCC(s)

Note 1 to entry: Further details regarding possible architectures are given in Annex A of ISO 15118-1:2019.

Note 2 to entry: Functions of a supply equipment communication controller may control input and output channels, data encryption, or digital communication between EVCC and SECC.

[SOURCE: ISO 15118-1:2019, 3.1.68, modified – Words "and which may be able to interact with secondary actors" deleted, Note 1 to entry deleted, and word "vehicle" replaced with EVCC in Note 3 to entry.]

**3.7.148****digital communication**

exchange of digitally encoded information

Note 1 to entry: HLC in the ISO 15118 series is compliant with the term digital communication in SAE J1772, SAE 2836, SAE 2847 and SAE 2931.

Note 2 to entry: See also IEC 61851-24 for additional information about digital communication exchanged between EV supply equipment and an EV.

[SOURCE: ISO 15118-1:2019, 3.1.47, modified, Note 2 to entry added]

**3.7.149****working voltage**

highest RMS value of the AC or DC voltage across any particular insulation which can occur when the equipment is supplied at rated maximum voltage of the EV supply equipment at side A and operated at the rated maximum voltage of the EV supply equipment at side B

Note 1 to entry: Transient overvoltages are disregarded.

Note 2 to entry: Both open-circuit conditions and normal operating conditions are taken into account.

[SOURCE: IEC 60050-851:2008, 851-12-31, modified – Words "rated voltage" replaced with the end of the definition starting with "rated maximum voltage".]

## 4 General requirements

IEC 61851-1:2017, Clause 4, is applicable, except as follows.

*The following sentence is not applicable:*

Assemblies for EV supply equipment shall comply with IEC 61439-7 with the exceptions or additions as indicated in Clause 13.

*Addition:*

NOTE In the following countries, the EV supply equipment is designed to be used at an altitude  $\leq 1\,000$  m according to the national standard: JP.

## 5 Classification

IEC 61851-1:2017, Clause 5, is applicable, except as follows.

*Additional subclauses:*

### 5.101 Characteristics of EV supply equipment

#### 5.101.1 Separation type

The EV supply equipment shall be classified according to the type of separation between side A and side B:

- separated EV supply equipment;
- non-separated EV supply equipment (under consideration)

#### 5.101.2 Control system

The EV supply equipment shall be classified according to the type of control system:

- regulated EV supply equipment:
  - a) controlled current mode;
  - b) controlled voltage mode;
  - c) combination of a) and b);
- non-regulated EV supply equipment (under consideration).

#### 5.101.3 System

The EV supply equipment shall be classified according to the system:

- system A (see Annex AA);
- system B (see Annex BB);
- system C (see Annex CC).

#### 5.101.4 Thermal management system

The EV supply equipment shall be classified according to the thermal management system of the side B cable assembly:

- using thermal sensing;
- using thermal sensing and thermal transport;
- none.

### **5.101.5 Power distribution system**

The EV supply equipment shall be classified according to the power distribution system to which the EV supply equipment is intended to be connected in its final application:

- single-phase equipment on star TN or TT system;
- single-phase equipment on centre-earthed TN or TT system;
- single-phase equipment connected line-to-line on star TN or TT system;
- single-phase equipment connected line-to-neutral on star IT system;
- single-phase equipment connected line-to-line on star IT system;
- three-phase equipment on star TN or TT system;
- three-phase equipment on star IT system;
- three-phase equipment on unearthed delta system;
- three-phase equipment on centre-earthed delta system.

## **6 Charging modes and functions**

IEC 61851-1:2017, Clause 6, is applicable, except as follows.

### **6.2 Charging modes**

#### **6.2.1 Mode 1**

IEC 61851-1:2017, 6.2.1, is not applicable.

#### **6.2.2 Mode 2**

IEC 61851-1:2017, 6.2.2, is not applicable.

#### **6.2.3 Mode 3**

IEC 61851-1:2017, 6.2.3, is not applicable.

### **6.3 Functions provided in Modes 2, 3 and 4**

*Replacement of the title of this subclause:*

#### **6.3 Functions provided in Mode 4**

##### **6.3.1 Mandatory functions in Modes 2, 3 and 4**

*Replacement of the title of this subclause:*

##### **6.3.1 Mandatory functions in Mode 4**

###### **6.3.1.1 General**

*Replacement:*

The EV supply equipment shall supply a DC current and voltage to the EV battery system according to an EVCC request.

The following functions shall be provided by EV supply equipment:

- continuous continuity checking of the protective conductor according to 6.3.1.2;
- verification that the EV is properly connected to the EV supply equipment according to 6.3.1.3;
- energization of the power supply to the EV according to 6.3.1.4;
- de-energization of the power supply to the EV according to 6.3.1.5;
- maximum allowable current according to 6.3.1.6;
- DC supply for EV according to 6.3.1.101;
- measuring current and voltage according to 6.3.1.102;
- latching of the vehicle coupler according to 6.3.1.103;
- compatibility check according to 6.3.1.104;
- insulation resistance check before energy transfer according to 6.3.1.105;
- protection against overvoltage between DC+ and DC– according to 6.3.1.106;
- verification of vehicle connector latching according to 6.3.1.107;
- control circuit supply integrity according to 6.3.1.108;
- short-circuit check before energy transfer according to 6.3.1.109;
- user initiated shutdown according to 6.3.1.110;
- overload protection for parallel conductors (conditional function) according to 6.3.1.111;
- voltage limitation between side B live parts (DC+ and DC–) and protective conductor according to 6.3.1.112;
- shutdown of EV supply equipment according to 6.3.1.113.

The EV manufacturer should consider the requirements for overvoltage and overcurrent according to this document and ISO 17409.

If the EV supply equipment can supply more than one EV simultaneously, the EV supply equipment shall provide all functions listed above independently at each vehicle connector.

### **6.3.1.2 Continuous continuity checking of the protective conductor**

*Replacement:*

The protective conductor continuity between the EV supply equipment and the EV shall be monitored continuously. The EV supply equipment shall trigger and complete an emergency shutdown according to 6.3.1.113.4 and according to:

- AA.3.8.2 for system A;
- BB.5.1 for system B;
- CC.4.7 for system C;

after a loss of electrical continuity of the protective conductor between the EV supply equipment and EV.

NOTE Protective conductor continuity is monitored by the control pilot function.

*Compliance for system A and system B is checked by the following test. Compliance for system C is checked by CC.7.6.3.*

*The test setup for system A is shown in Figure 129. The test setup for system B is shown in Figure 130.*

The test shall be performed according to the following procedure.

- 1) Connect the EV supply equipment to a test load with a dedicated EV simulator for each system.
- 2) Measure  $V_{T8}$  and  $A_{T1}$  continuously.
- 3) Start a communication session with the procedure specified by the EV supply equipment manufacturer.
- 4) Confirm that side B is at OP4, specified in Figure 133.
- 5) Open  $S_{T15}$ .
- 6) Check that the EV supply equipment triggered and completed an emergency shutdown.
- 7) Check the result in Table 101.

**Table 101 – Verification criterion**

System	Verification criterion
A	See Table AA.8.
B	The present current at side B ( $A_{T1}$ ) is $\leq 5$ A DC in $t_{pe}$ or less after the loss of protective conductor continuity. The $t_{pe}$ includes the detection time and fall time of the current. See Table BB.3 for the specific time.

Confirm that  $V_{T8} \leq 60$  V DC.

### 6.3.1.3 Verification that the EV is properly connected to the EV supply equipment

This subclause of IEC 61851-1:2017 is applicable.

### 6.3.1.4 Energization of the power supply to the EV

*Addition:*

Further requirements for normal startup are given in CC.3.2 for system C.

*Compliance is checked by the following test.*

The test setup for system A is shown in Figure 129. The test setup for system B is shown in Figure 130. The test setup for system C is shown in Figure 131.

The test shall be performed according to the following procedure.

- 1) Connect the EV supply equipment to a test load with a dedicated EV simulator for each system.
- 2) Measure  $V_{T8}$  continuously.
- 3) Simulate the open circuit of the control pilot by opening the switch for each system shown below:
  - system A:  $S_{T5}$ ;
  - system B:  $S_{T4}$ ;
  - system C:  $S_{T3}$ ;
- 4) Start a communication session with the procedure specified by the EV supply equipment manufacturer.
- 5) Confirm that  $V_{T8} \leq 60$  V DC.

### **6.3.1.5 De-energization of the power supply to the EV**

*Replacement:*

If the pilot signal is interrupted, the EV supply equipment shall perform a shutdown as indicated for each system.

*Compliance is checked for system A by the test in AA.3.2, for system B by the test in BB.5.5, and for system C by the test in CC.7.6.6.*

*Additional subclause:*

#### **6.3.1.5.101 De-energization in case of failure in control circuit**

In case of failure in the control circuit of the EV supply equipment, such as short-circuit, earth leakage current, SECC failure or excess temperature, the EV supply equipment shall terminate the supply of current at side B. The EV supply equipment manufacturer shall perform a failure modes and effects analysis (FMEA) according to IEC 60812 to show conformity with the above requirement.

*Compliance is checked by inspection.*

### **6.3.1.6 Maximum allowable current**

*Replacement:*

A means shall be provided to inform the EV of the value of the applicable maximum current of the EV supply equipment at side B. The value of the applicable maximum current of the EV supply equipment at side B shall be communicated and shall be less than or equal to the rated boost current of the EV supply equipment at side B.

The communicated value may change, without being more than the rated boost current of the EV supply equipment at side B, to adapt to power limitations, for example, for load management.

*Compliance is checked by design review for system A, system B and system C.*

*Additional subclauses:*

#### **6.3.1.101 DC supply for the EV**

The EV supply equipment shall supply controlled DC voltage or current (not simultaneously, but as requested by the EV during the communication session) to the EV according to the EVCC requests. Requirements for energy transfer performance of regulated DC voltage or current are given in 101.1.1, 101.1.2, 101.1.3, 101.1.4, 101.1.5, and 101.1.6.

In either case mentioned above, the supplied regulated values shall be less than or equal to the maximum ratings of the EV supply equipment.

*Compliance is checked by the applicable tests in 101.1.1 through 101.1.6.*

The EV can change the target current of the EV and/or the target voltage of the EV.

NOTE EVs are equipped with different technologies and battery systems with different voltages. In order to avoid any error during energy transfer and to guarantee that the EV supply equipment will be able to transfer energy to all existing and future battery systems, any communication session is controlled by the EV. Any EV that is to be connected to a EV supply equipment is equipped with an EVCC for controlling the communication session.

### 6.3.1.102 Measuring current and voltage

The EV supply equipment shall measure the present current and the present voltage at side B. The accuracy of these measurements shall meet the defined accuracy for each system in AA.4.4, BB.4.2 and CC.6.3.

The measured values of present voltage and present current at side B shall be provided by the EV supply equipment to the EV through digital communication.

*Compliance for system A and system B is checked by the following test. Compliance for system C is checked by CC.7.6.9, CC.7.6.10, and CC.7.6.17.*

*The test setup for system A is shown in Figure 129. The test setup for system B is shown in Figure 130.*

*For system A:*

*The test shall be performed according to the following procedure.*

- 1) *Connect the EV supply equipment to a test load with a dedicated EV simulator for the system under test.*

*NOTE 1 Test load indicated in Figure 132 unless otherwise specified.*

- 2) *Start a communication session with the procedure specified by the EV supply equipment manufacturer.*
- 3) *Set the target current of the EV simulator at  $I_{EVSE\_rated\_boost\_sideB}$ ,  $I_{Avg}$  and  $I_{Min}$  of the EV supply equipment which are defined as:*

*$I_{EVSE\_rated\_boost\_sideB}$  = rated boost current of the EV supply equipment at side B*

*$I_{Avg}$  =  $I_{EVSE\_rated\_boost\_sideB} / 2$*

*$I_{Min}$  = 5 A*

- 4) *Set the target voltage of the EV simulator at  $V_{EVSE\_rated\_max\_sideB}$ ,  $V_{Avg}$  and  $V_{EVSE\_rated\_min\_sideB}$  of the EV supply equipment which are defined as:*

*$V_{EVSE\_rated\_max\_sideB}$  = rated maximum voltage of the EV supply equipment at side B*

*$V_{Avg}$  =  $(V_{EVSE\_rated\_max\_sideB} + V_{EVSE\_rated\_min\_sideB}) / 2$*

*$V_{EVSE\_rated\_min\_sideB}$  = rated minimum voltage of the EV supply equipment at side B*

*The side B voltage is set to  $V_{EVSE\_rated\_max\_sideB}$ ,  $V_{Avg}$  and  $V_{EVSE\_rated\_min\_sideB}$  of the EV supply equipment by one of the following measures:*

- *$A_{T1}$  shall be adjusted to set  $V_{T8}$  at  $V_{EVSE\_rated\_max\_sideB}$ ,  $V_{Avg}$  and  $V_{Min}$  of the EV supply equipment with either the electronic load  $U_{T5}$  operating at constant resistance or using the resistors  $R_{T10}$  and  $R_{T11}$  to set the voltage point;*
- *electronic load  $U_{T5}$  shall be operated under the constant voltage mode.*

- 5) *Trend a chart of  $V_{T8}$  and  $A_{T1}$ .*

- 6) *Check that the difference between the measured current and voltage of the EV supply equipment at side B and the values measured with  $V_{T8}$  and  $A_{T1}$  are between the limits specified in AA.4.4.*

*For system B:*

- 1) *Connect the EV supply equipment to a test load with a dedicated EV simulator for the system under test.*

*NOTE 2 Test load indicated in Figure 132 unless otherwise specified.*

- 2) Start a communication session with the procedure specified by the EV supply equipment manufacturer.
- 3) Set the target current of the EV simulator at  $I_{EVSE\_rated\_boost\_sideB}$ ,  $I_{Med}$  and  $I_{Min}$  of the EV supply equipment which are defined as:

$I_{EVSE\_rated\_boost\_sideB}$  = rated boost current of the EV supply equipment at side B

$I_{Med} = (I_{EVSE\_rated\_boost\_sideB} + I_{Min}) / 2$

$I_{Min}$  = the higher value between 5 A and rated minimum current specified of the EV supply equipment at side B

- 4) Set the target voltage of the EV simulator at  $V_{EVSE\_rated\_max\_sideB}$ ,  $V_{Med}$  and  $V_{EVSE\_rated\_min\_sideB}$  of the EV supply equipment which are defined as:

$V_{EVSE\_rated\_max\_sideB}$  = rated maximum voltage of the EV supply equipment at side B

$V_{Med} = (V_{EVSE\_rated\_max\_sideB} + V_{EVSE\_rated\_min\_sideB}) / 2$

$V_{EVSE\_rated\_min\_sideB}$  = rated minimum voltage of the EV supply equipment at side B

- 5) Trend a chart of  $V_{T8}$  and  $A_{T1}$ .
- 6) Check that the difference between the measured current and voltage of the EV supply equipment at side B and the values measured with  $V_{T8}$  and  $A_{T1}$  are between the limits specified in BB.4.2.

### 6.3.1.103 Latching of the vehicle connector

The requirements for latching the vehicle connector are defined in Annex AA, Annex BB and Annex CC for each system.

Once latched, the vehicle connector shall remain latched until the present voltage at side B between DC+ and DC– is < 60 V DC. This voltage limit applies throughout the coupling session including after the energy transfer stage. In case of an EV supply equipment malfunction, a means for disconnection may be provided, but if provided, that disconnection means shall be safe according to this document.

NOTE 1 The actuation portion of the latching function can be in either the vehicle connector or the vehicle inlet.

NOTE 2 Voltage criteria for latching/unlatching function can be < 60 V DC; for example, 30 V DC in system A.

The EV supply equipment shall have the following functions when the latching is done by the EV supply equipment:

- electrical or mechanical latching function to retain the latched status;
- function to detect the disconnection of the electrical circuits for the latching function.

Additional requirements are given in AA.3.6, BB.5.9 and CC.4.2. Specific voltage for system A is specified in AA.3.3.

Compliance is checked by the following tests a) and b).

#### a) Normal condition test

Simulate a normal coupling session. Check that the vehicle connector is latched on the vehicle inlet whenever the present voltage at side B between DC+ and DC– is  $\geq 60$  V DC.

#### b) Abnormal condition test

Simulate a condition in which the present voltage at side B between DC+ and DC– remains  $\geq 60$  V DC after the end of the energy transfer stage, for example, by keeping the EV disconnection device closed. Check that the vehicle connector is latched on the vehicle inlet whenever the present voltage at side B between DC+ and DC–  $\geq 60$  V DC.

Vehicle connectors and vehicle inlets shall comply with the requirements of IEC 62196-1 and IEC 62196-3. See also 9.101.

### 6.3.1.104 Compatibility check

Compatibility between the EV and the EV supply equipment shall be checked with the information exchanged at the preparation phase.

For system A, the EV supply equipment shall check if target voltage and rated minimum voltage of the EV ("target battery voltage" and "minimum battery voltage" in IEC 61851-24) are between the rated maximum and rated minimum voltage of the EV supply equipment at side B. In case this condition is not met, the EV supply equipment shall trigger an error shutdown.

For system B, the EV supply equipment checks that rated minimum voltage of the EV supply equipment at side B is less than the maximum permissible charge voltage. In case this condition is not met, the EV supply equipment shall trigger an error shutdown.

For system C, see CC.5.6.

*Compliance for system A and system B is checked by the following test. Compliance for system C is checked by CC.7.5.1.*

*The test setup for system A is shown in Figure 129. The test setup for system B is shown in Figure 130.*

- 1) *Connect the EV supply equipment to a test load with a dedicated EV simulator for the system under test.*
- 2) *Start energy transfer with the procedure specified by the EV supply equipment manufacturer.*
- 3) *Using the EV simulator, communicate the data or message in Table 102 to the EV supply equipment via digital communication.*

**Table 102 – Data/message for the compatibility check test**

System	Data/Message (refer to IEC 61851-24)	Value
A (case 1)	Target battery voltage	420 V
	Maximum battery voltage	410 V
A (case 2)	Target battery voltage	Rated maximum voltage of the EV supply equipment at side B + 10 V
	Maximum battery voltage	600 V
A (case 3)	Target battery voltage	Rated minimum voltage of the EV supply equipment at side B – 10 V
	Maximum battery voltage	Rated maximum voltage of the EV supply equipment at side B
B	Maximum permissible charge voltage of battery system	Rated minimum voltage of the EV supply equipment at side B – 10 V

- 4) *For each case, check that the EV supply equipment triggers an error shutdown, displaying a relevant alarm or error information, if any. For system A, perform the test separately for each case.*
- 5) *Confirm that  $V_{T6}$ ,  $V_{T7}$  and  $V_{T8}$  are < 60 V DC.*

### 6.3.1.105 Insulation resistance check before energy transfer

The EV supply equipment shall check the insulation resistance between side B live parts (DC+/DC–) and protective conductor to the vehicle chassis, including any exposed conductive part of the EV supply equipment, before the EV disconnection device are allowed to close.

If the insulation resistance is less than the system specific limit or it cannot be determined in the specified time or less, the EV supply equipment shall trigger an error shutdown and indicate to the EV that energy transfer is not allowed.

For system A and system B, when the insulation resistance  $R$  does not fulfil Formula (1), the EV supply equipment shall trigger an error shutdown:

$$R \geq 100 \frac{\Omega}{V} \times U \quad (1)$$

where

$U$  is the rated maximum voltage of the EV supply equipment at side B, expressed in volts. Details are specified in AA.4.3.3 and BB.8.

For system C, see CC.4.1.4.

*Compliance is checked by the tests in AA.4.3.3, BB.8 and CC.7.6.13.*

### 6.3.1.106 Protection against overvoltage at side B between DC+ and DC–

#### 6.3.1.106.1 General

The EV supply equipment shall detect an overvoltage between DC+ and DC– at the vehicle connector and perform an emergency shutdown or error shutdown if an overvoltage is detected, according to 6.3.1.106.2 and 6.3.1.106.3.

When the vehicle connector is being mated to the vehicle inlet, the EV supply equipment and the EV shall not trigger a shutdown due to a present voltage at side B (positive or negative voltage), between DC+ and DC–, between DC+ and PE or between DC– and PE, unless otherwise specified in 6.3.1.112, Annex AA, Annex BB and Annex CC.

According to ISO 17409:2020, 6.5.2, when unmated, the EV can have a voltage > 60 V DC and > 30 V AC between DC+ and PE, and between DC– and PE. It is recommended that the EV does not have a common mode voltage > 60 V, as unbalanced insulation faults can generate differential voltages at side B > 60 V. For system C, the EV may try to use  $R_{s6}$  and  $R_{s7}$  in Figure CC.3 of the disabled side B circuit to limit this common mode voltage.

Overvoltage protection during the initialization stage, cable-check phase and pre-charge phase is under consideration.

#### 6.3.1.106.2 Protection against overvoltage at side B between DC+ and DC– by emergency shutdown

For system A, the EV supply equipment shall fulfil the overvoltage protection requirements in AA.3.12.

For system B and system C, the EV supply equipment shall trigger an emergency shutdown in 1 ms or less if, during the energy transfer stage, the present voltage at side B between DC+ and DC– is more than the voltage thresholds specified in Table 103 for more than 9 consecutive ms.

**Table 103 – Voltage threshold for emergency shutdown reaction for system B and system C**

Negotiated maximum voltage at side B ( $U$ )	Voltage threshold V
$U \leq 500$ V	550
$500$ V < $U \leq 750$ V	825
$750$ V < $U \leq 850$ V	935
$850$ V < $U \leq 1\ 000$ V	1 100

Compliance is checked by BB.5.6 for system B and CC.7.6.5.1 for system C.

### 6.3.1.106.3 Protection against overvoltage at side B between DC+ and DC– by error shutdown

The EV supply equipment shall also react depending on condition of the present voltage at side B between DC+ and DC– according to Table 104.

**Table 104 – EV supply equipment reaction depending on the present voltage at side B condition**

Present voltage at side B condition	System	EV supply equipment reaction
The present voltage at side B between DC+ and DC– is more than the negotiated maximum voltage at side B for 400 consecutive ms	A	Trigger an error shutdown in 1,6 s or less
	C	Trigger an error shutdown in 50 ms or less
The present voltage at side B between DC+ and DC– is more than the negotiated maximum voltage at side B for more than 200 consecutive ms and less than 400 consecutive ms	A and C	Allow energy transfer or trigger an error shutdown
The present voltage at side B between DC+ and DC– is more than the negotiated maximum voltage at side B for 200 or less consecutive ms	A and C	Allow energy transfer
The present voltage at side B between DC+ and DC– is more than the negotiated maximum voltage at side B	B	Trigger an error shutdown in 500 ms or less

NOTE 1 For system A and system B, the EV cannot change the applicable maximum voltage of the EV during the communication session.

For system A, specific requirements for the error shutdown timing criteria are defined in Table AA.5.

NOTE 2 The emergency and error shutdown are necessary to prevent overcharging the battery system and cannot be assumed as a withstand capability of the EV supply equipment.

Compliance is checked by the following tests according to Table 105.

**Table 105 – Compliance tests for protection against overvoltage at side B between DC+ and DC–**

Fault scenario	System A	System B	System C
The EV switches a voltage source and the present voltage at side B between DC+ and DC– becomes more than the rated maximum voltage of the EV	Test a) and test b)	Test a)	CC.7.6.5.2 CC.7.6.5.3
The EV modifies the applicable maximum voltage of the EV to a value less than the present voltage at side B	Not applicable	Not applicable	CC.7.6.5.4

Test a)

The test setup for system A is shown in Figure 129. The test setup for system B is shown in Figure 130.

The test shall be performed according to the following procedure.

- 1) Connect the EV supply equipment to a test load with a dedicated EV simulator for the system under test. The setup of the test load in Figure 132 is in Table 106.

**Table 106 – Test load setup for protection against overvoltage test**

System	Switches					Circuit parameter setup
	S <sub>T</sub> 17 S <sub>T</sub> 18	S <sub>T</sub> 19	S <sub>T</sub> 20	S <sub>T</sub> 21	S <sub>T</sub> 22	
A	closed	closed	closed	open	open	L <sub>T</sub> : 0 H R <sub>T</sub> 10: 0 Ω (bypassed) U <sub>T</sub> 4: not used U <sub>T</sub> 5: an electronic load operating under constant voltage mode shall be used
B	closed	closed	open	closed	open	L <sub>T</sub> : 0 H R <sub>T</sub> 10: 0 Ω R <sub>T</sub> 11: variable U <sub>T</sub> 4: controlled voltage source C <sub>T</sub> 5: 5 600 μF (different case dependent)

- 2) Measure V<sub>T</sub>8 and A<sub>T</sub>1 continuously.
- 3) Start energy transfer with the procedure specified by the EV supply equipment manufacturer.
- 4) Using the EV simulator, communicate the data or message in Table 107 to the EV supply equipment via digital communication.

**Table 107 – Data/messages for protection against overvoltage test**

System	Data/Message name	Value
A	Target voltage of the EV	410 V
	Rated maximum voltage of the EV	420 V
	Target current of the EV	$I_{EVSE\_max}$
B	Applicable maximum voltage of the EV	≤ rated maximum voltage of the EV
	Target voltage of the EV	= negotiated maximum voltage at side B – 10 V

- 5) Confirm that  $V_{T8}$  is at the negotiated maximum voltage at side B and the EV supply equipment is operating at the designated OP.
- 6) Simulate an overvoltage at side B between DC+ and DC– by the methods in Table 108 and check the results.

**Table 108 – Overvoltage condition and verification criterion**

System	Methods to simulate overvoltage at side B between DC+ and DC–	Verification criterion
A	Adjust $U_{T5}$ to increase $V_{T8}$ to 430 V DC $\pm$ 3 V DC during 400 ms	See Table AA.5.
B	Adjust $U_{T4}$ to increase $V_{T8}$ to 15 V $\pm$ 3 V more than the negotiated maximum voltage at side B	The present current at side B ( $A_{T1}$ ) is $\leq$ 5 A DC in 1 s or less after the overvoltage is applied. The present voltage at side B ( $V_{T8}$ ) is $\leq$ 60 V DC in 1 s or less after the overvoltage is applied.

Test b)

The test setup for system A is shown in Figure 129. The test setup for system B is shown in Figure 130.

Execute the same procedure than in test a) until step 5).

- 6) Simulate an overvoltage at side B between DC+ and DC– by adjusting  $U_{T5}$  for system A or  $U_{T4}$  for system B, increasing  $V_{T8}$  to 430 V  $\pm$  3 V, and then decreasing  $V_{T8}$  to 410 V  $\pm$  3 V. The purpose is to have  $V_{T8} > 420$  V for less than 200 ms, as shown in Figure 102.
- 7) Check that the EV supply equipment allows energy transfer.

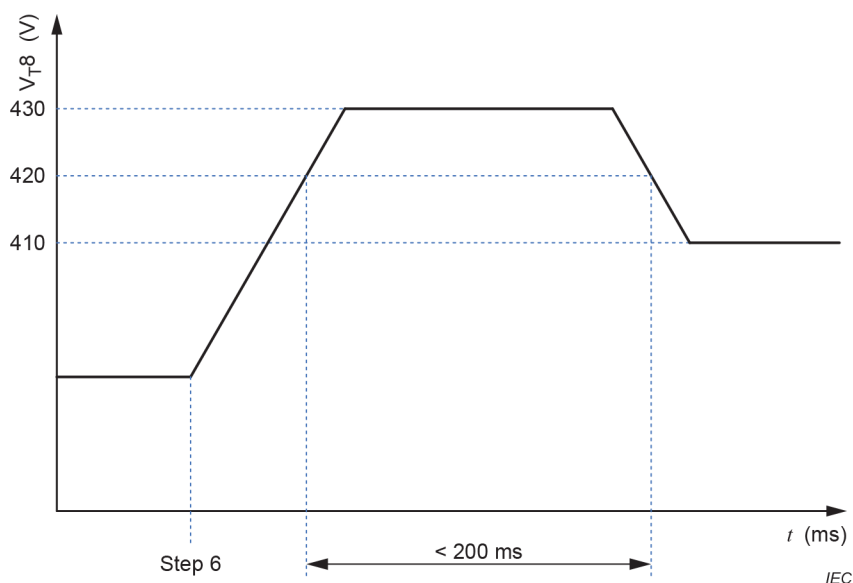

**Figure 102 – Voltage  $V_{T8}$  to apply to simulate short period overvoltage at side B between DC+ and DC–**

**6.3.1.107 Verification of vehicle connector latching**

Subclause 6.3.1.107 is only applicable for EV supply equipment such as system A and system B, which are responsible for latching of vehicle connector.

The EV supply equipment shall not energize the side B cable assembly when the vehicle connector is unlatched.

*Compliance is checked by inspection, operation and AA.3.6 for system A, BB.5.9 for system B.*

**6.3.1.108 Control circuit supply integrity**

If an earth fault, short-circuit or overcurrent is detected at side B, the power supply for the control circuit of the EV supply equipment shall not be interrupted until the FPT sequence is completed and the vehicle coupler is safely unlatched.

*Compliance is checked by the following tests according to Table 109.*

**Table 109 – Control circuit supply integrity test**

Fault scenario	System A	System B	System C
Earth fault	AA.3.1.2	BB.5.11	CC.7.6.14
Short-circuit	AA.3.8.3	BB.5.8	CC.7.6.16
Overcurrent	AA.3.4	Design review <sup>a</sup>	Design review
<sup>a</sup> For system B, FS1 and S <sub>S2</sub> shall be designed according to Figure BB.1.			

**6.3.1.109 Short-circuit check before energy transfer**

With the EV mated to the EV supply equipment and before the EV disconnection device is closed, the EV supply equipment shall have a means to check for a short-circuit between side B live parts (DC+/DC–) up to the EV disconnection device.

If short-circuit is detected, the EV supply equipment shall perform an error shutdown.

*Compliance for system A and system B is checked by the following test. For system C, see CC.7.6.20.*

*The test setup for system A is shown in Figure 129. The test setup for system B is shown in Figure 130.*

*The test shall be performed according to the following procedure.*

- 1) *Connect the EV supply equipment to a test load with dedicated EV simulator for each system.*
- 2)  *$S_{T17}$  and  $S_{T18}$  are open.*
- 3) *The short-circuit resistance  $R_{T2}$  shall be  $100 \Omega \pm 20 \%$ . The short-circuit inductance  $L_{T1}$  shall be  $0 \text{ mH}$ .*
- 4) *Switch  $S_{T8}$  is open.*
- 5) *Simulate the short-circuit at side B between DC+ and DC– by closing the switch  $S_{T8}$ .*
- 6) *Start energy transfer with the procedure defined by the EV supply equipment manufacturer.*
- 7) *The EV supply equipment shall trigger an error shutdown before  $S_{T17}$  and  $S_{T18}$  are allowed to close.*

#### **6.3.1.110 User initiated shutdown**

The EV supply equipment shall have a means to allow the user to initiate a normal shutdown anytime during the coupling session. The activation of this means may depend on an authorization by the user.

NOTE 1 The EV can also have a means for the user to initiate a normal shutdown.

NOTE 2 For system A, a means to trigger an error shutdown is also possible.

*Compliance is checked by the tests in AA.8, BB.4.5 or CC.7.6.18.*

#### **6.3.1.111 Overload protection for parallel conductors (conditional function)**

If more than one conductor or wire is used in parallel, the EV supply equipment shall be designed such that none of the conductors or wires will be overloaded.

*Compliance is checked by verifying that the parallel conductors*

- are the same length,*
- consist of the same conductor material,*
- are the same cross-section,*
- have the same insulation type, and*
- are terminated in the same manner.*

If more than one vehicle connector contact is used in parallel for DC+ or DC–, the EV supply equipment shall be designed such that none of the contacts will be overloaded.

NOTE For example, the currents on the different path can be monitored, the contact temperature can be monitored, or more than one power source can be used.

*Compliance is checked by design review.*

### **6.3.1.112 Voltage limitation between side B live parts (DC+ and DC–) and protective conductor**

#### **6.3.1.112.1 Maximum voltage between side B live parts (DC+ and DC–) and protective conductor under normal operation**

Under normal operation, at side B, no voltage more than the present voltage between DC+ and DC– plus 50 V DC shall occur between live parts (DC+ and DC–) and protective conductor. This voltage limitation does not apply for transient overvoltages. See Figure 103 and Figure 104.

Components of the EV supply equipment, for example, an IMD, may superimpose a common mode voltage to protective conductor onto the present voltage at side B. This may shift the voltage between side B live parts (DC+/DC–) and the protective conductor up to present voltage at side B plus 50 V DC.

Components of the EV supply equipment, for example, resistors, may shift each side B live part (DC+/DC–) up to protective conductor through a resistor, which results in a large common mode side B voltage swing.

The measurement circuits might introduce a larger common mode voltage offset if connected to an intermediate bus voltage. These circuits shall not cause a voltage shift that is more than the requirements in 6.3.1.112.

The EV supply equipment may employ passive and/or active techniques to minimize the touch impulse current, possibly in coordination with the IMD or earth fault monitor of the EV supply equipment.

NOTE Close to symmetrical, voltages between side B live parts (DC+/DC–) and the protective conductor help to minimize the touch impulse current.

Figure 103 shows an example of a correct implementation and Figure 104 shows an example of an incorrect implementation.

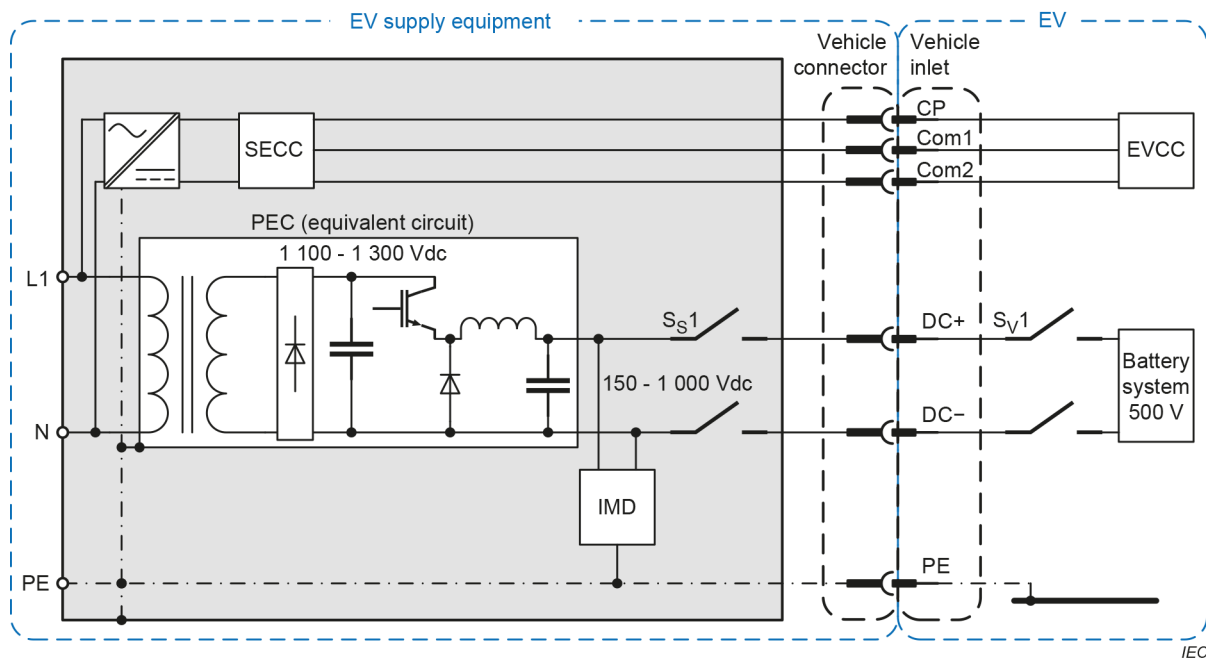

a) Typical IMD implementation

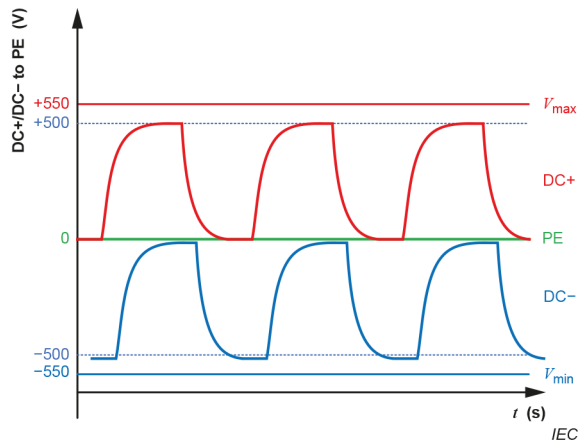

b) Waveform of an IMD implementation with a switched resistor

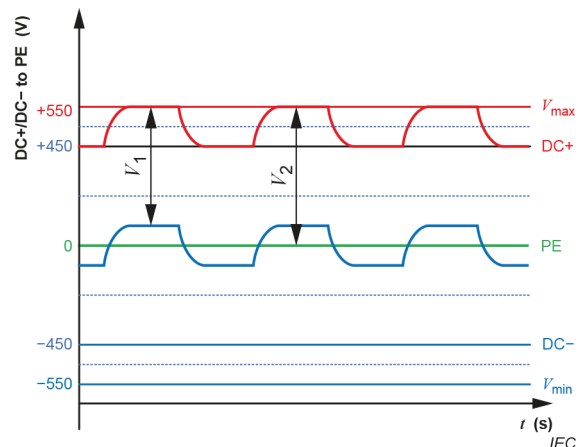

c) Waveform of an IMD implementation with a pulsed signal

**Key**

$V_1$	voltage at side B between DC+ and DC-	$V_{max}$	upper voltage limit for DC+ and DC-
$V_2$	maximum common mode voltage (that is, with reference to PE) including IMD	$V_{min}$	lower voltage limit for DC+ and DC-
PE	protective conductor		

NOTE 1 If the voltage between DC+/DC- and protective conductor is > 704 V DC, the required C1 impulse current limitation specified as special protection in 8.105.1 cannot be met.

NOTE 2 System A requires relatively low earthing resistance for earth leakage current monitoring, and large offset shown in Figure 103 does not occur in normal operational condition.

**Figure 103 – Typical voltages between side B live parts (DC+/DC-) and protective conductor under normal operation**

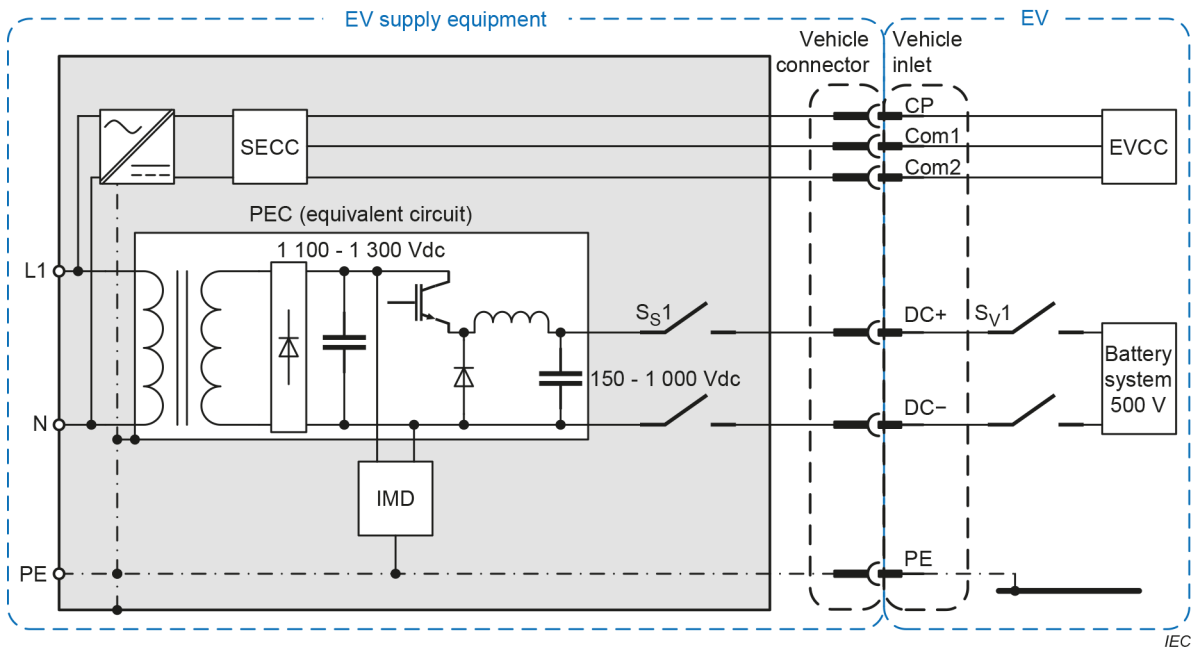

a) Incorrect IMD implementation

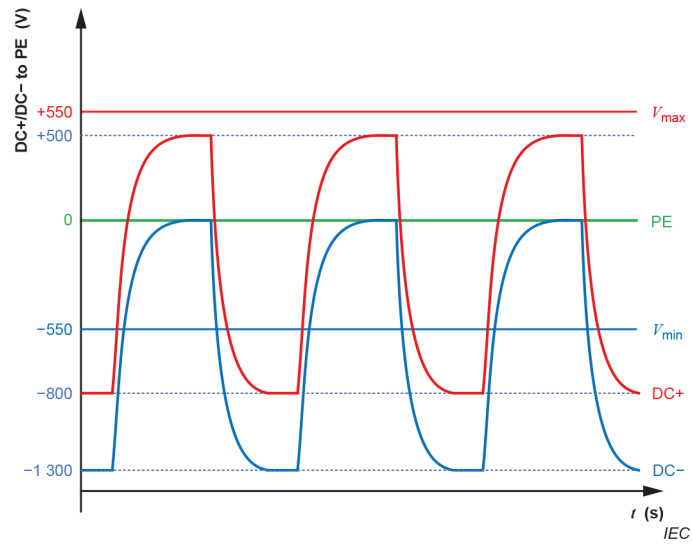

b) Waveform of an incorrect IMD implementation

**Key**

- $V_{max}$  upper voltage limit for DC+ and DC-      PE protective conductor
- $V_{min}$  lower voltage limit for DC+ and DC-

**Figure 104 – IMD connection which results in a voltage more than the maximum voltage limits**

Compliance is checked by the following test:

The test setup for system A is shown in Figure 129. The test setup for system B is shown in Figure 130. The test setup for system C is shown in Figure 131.

1) *Preconditions for the test:*

- The EV simulator shall use the following limits  $V_{EV\_rated\_max} = V_{EVSE\_rated\_max\_sideB}$  and  $I_{EV\_rated\_max} = I_{EVSE\_rated\_boost\_sideB}$  during the compatibility check (see 6.3.1.104) in order to not limit the operating range.
- For system A and system C: The EV simulator shall draw current during this test, in order to reach and maintain power transfer.

2) *The following voltage and current values shall be applied:*

- $V_{EV\ simulator} = 0,8 \times V_{EVSE\_rated\_max\_sideB}$
- $I_{EVSE\ intended} = I_{EV\_trg} = I_{EVSE\_rated\_boost\_sideB} / 2$

3) *Perform the following actions:*

- For system A:
  - i) The FPT sequence shall be successfully done until state DC-C (energy transfer).
  - ii) Wait until  $A_{T1} \geq 80\%$  of  $I_{EVSE\ intended}$  for 5 s.
  - iii) Measure  $V_{T6}$ ,  $V_{T7}$  and  $V_{T8}$  continuously for 10 s.
- For system B:
  - i) The FPT sequence shall be successfully done until  $t6$  (IMD enabled).
  - ii) During  $t6$  (insulation resistance check), wait until  $V_{T8} \geq 80\%$  of  $V_{EVSE\_max}$ .
  - iii) Measure  $V_{T6}$ ,  $V_{T7}$  and  $V_{T8}$  continuously for 100 s.
- For system C:
  - i) The FPT sequence shall be successfully done until  $t = t8$  according to Figure CC.5, including the message "PowerDeliveryReq" (according to DIN SPEC 70121:2014 or ISO 15118-2:2014).
  - ii) Wait until  $A_{T1} \geq 80\%$  of  $I_{EV\_trg}$  for 5 s.
  - iii) Measure  $V_{T6}$ ,  $V_{T7}$  and  $V_{T8}$  continuously for 100 s.

Low pass filter shall be applied, in order to filter out transients. Recommended cut-off frequency: 10 Hz to 200 Hz.

4) *Check the expected results:  $V_{T6}$  and  $V_{T7}$  shall be less than or equal to the following limit:*

$$|V_{T6}| \leq V_{T8} + 50\text{ V DC and } |V_{T7}| \leq V_{T8} + 50\text{ V DC}$$

### 6.3.1.112.2 Maximum voltage between side B live parts (DC+/DC–) and protective conductor in case of an insulation fault at side B to the protective conductor

The insulation requirements between side B of the EV supply equipment and the protective conductor, excluding the side B cable assembly, depend on the working voltage. See 8.105.5.

Case 1: For a side B with a working voltage of  $\leq 550\text{ V DC}$ , basic protection shall be provided between this part of the circuit and the protective conductor.

Compliance is checked by inspection.

Case 2: For a side B with a working voltage of > 550 V DC, if a fault to the protective conductor causes a voltage between side B live parts (DC+/DC-) and protective conductor of less than or equal to 110 % of the present voltage at side B, basic protection shall be provided between this part of the circuit and the protective conductor. See fault A in Figure 105.

*Compliance is checked by inspection.*

Case 3: For a side B with a working voltage of > 550 V DC, if a fault to the protective conductor causes a voltage between side B live parts (DC+/DC-) and the protective conductor of more than 110 % of the present voltage at side B between DC+ and DC-, double or reinforced protection shall be provided between this part of the circuit and the protective conductor. See fault B in Figure 105.

NOTE 1 Threshold of 550 V DC is due to backward compatibility with IEC 61851-23:2014.

*Compliance is checked by inspection.*

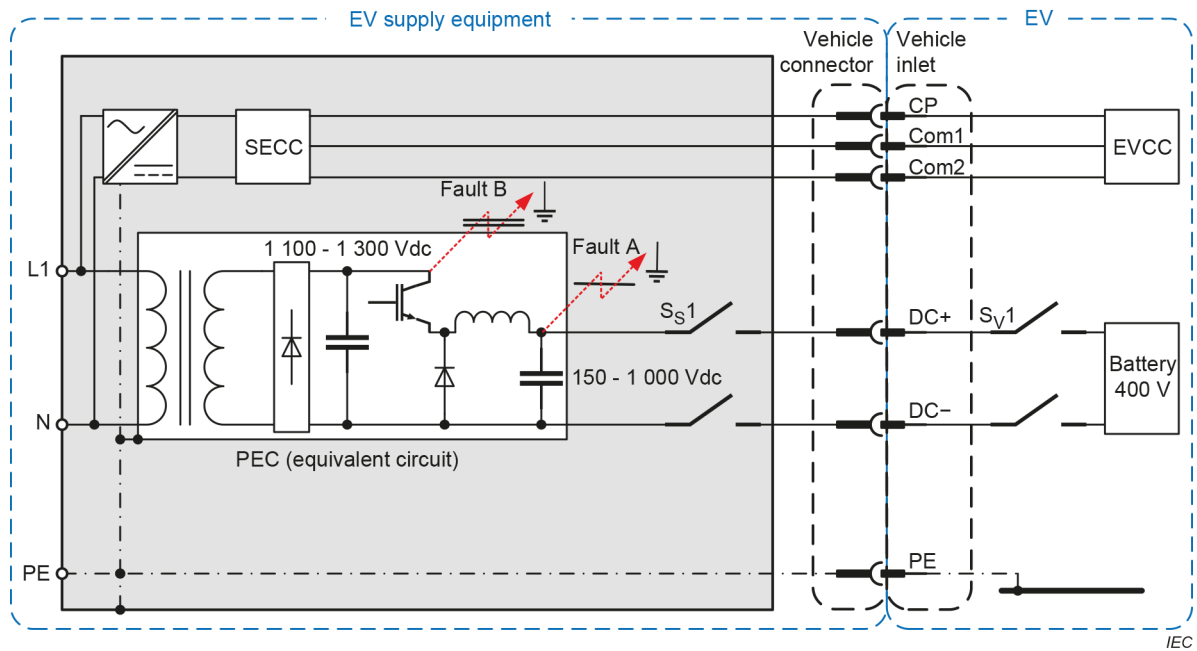

a) Fault locations

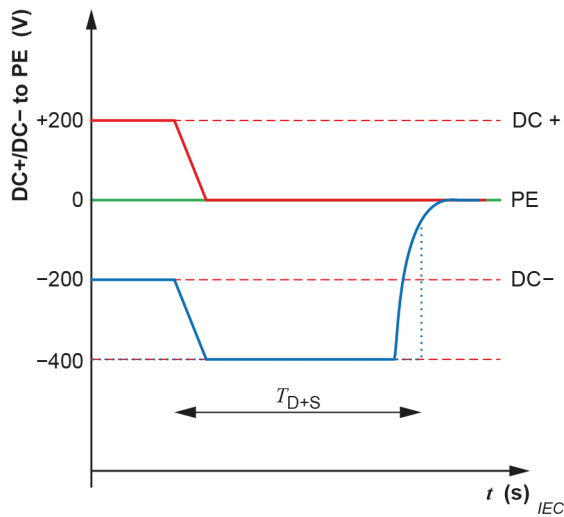

b) Waveform of fault A

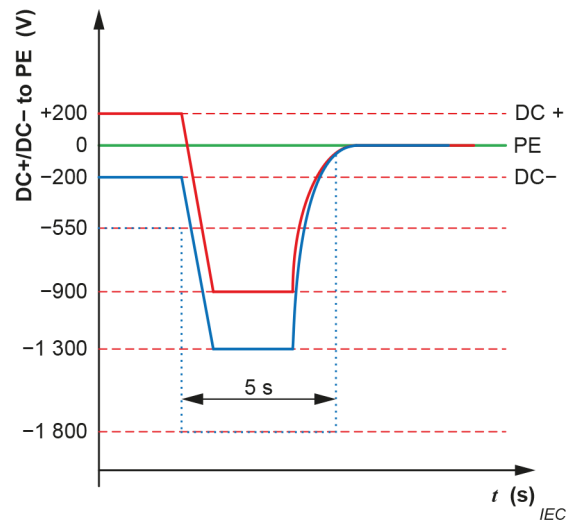

c) Waveform of fault B

**Key**

- PE protective conductor
- $T_{D+S}$  detection time of the IMD/earth leakage current monitoring device plus the error shutdown time
- (single line) basic insulation (see fault A)
- (double lines) double insulation or basic insulation and electrically protective screening (shielding) or reinforced insulation (see fault B)

**Figure 105 – Examples of a fault between the secondary circuit and the protective conductor**

The following requirements apply under a fault to the protective conductor.

For EV supply equipment based on case 3, with a rated maximum voltage of the EV supply equipment at side B of  $\leq 500$  V DC: if a voltage  $> 550$  V DC is present for more than 1 s between side B live parts (DC+/DC-) and the protective conductor, the EV supply equipment shall trigger and complete an error shutdown in 4 s or less. See Figure 105.

For EV supply equipment based on case 3, with a rated maximum voltage of the EV supply equipment at side B of  $> 500$  V DC and  $\leq 1\,000$  V DC: if a voltage more than 110 % of the present voltage at side B between DC+ and DC- is present for more than 1 s between side B live parts (DC+/DC-) and the protective conductor, the EV supply equipment shall trigger and complete an error shutdown in 4 s or less. See Figure 105.

In 5 s or less after a fault to the protective conductor, the EV supply equipment shall limit the temporary overvoltage  $V_{\text{toV}}$  between side B live parts (DC+/DC-) and the protective conductor to 1 800 V DC.

NOTE 2 Side B voltages between DC+ and DC-  $> 1\,000$  V DC are under consideration.

*Compliance is checked by the following tests.*

*The test setup for system A is shown in Figure 129. The test setup for system B is shown in Figure 130. The test setup for system C is shown in Figure 131.*

*Test between DC- and the protective conductor:*

- 1) *Connect the EV supply equipment to a test load with dedicated EV simulator for each system.*
- 2) *Measure voltages  $V_{T6}$ ,  $V_{T7}$ ,  $V_{T8}$  and current  $A_{T1}$ .*
- 3) *Start energy transfer with the procedure specified by the EV supply equipment manufacturer.*
- 4) *Confirm that the operating point is at OP2 as specified in Figure 133.*
- 5) *Preconditions for the fault condition:*
  - a)  *$R_{T4}$  shall be 150 k $\Omega$ ;*
  - b)  *$U_{T2}$  shall be set in order that, when  $S_{T10}$  is closed,  $V_{T7}$  is*
    - i)  *$(0,1 \times V_{EVSE\_rated\_max\_sideB})$  if  $V_{EVSE\_rated\_max\_sideB}$  is  $> 500$  V DC, or*
    - ii)  *$550 \text{ V} - V_{EVSE\_rated\_max\_sideB}$  if  $V_{EVSE\_rated\_max\_sideB}$  is  $\leq 500$  V DC.*
- 6) *Close  $S_{T10}$ .*
- 7) *Check that the EV supply equipment performs an error shutdown.*
- 8) *Check that  $V_{T6}$  and  $V_{T7}$  are  $< 60$  V DC in 5 s or less after closing  $S_{T10}$ .*

*Test between DC+ and the protective conductor.*

- 1) *Connect the EV supply equipment to a test load with dedicated EV simulator for each system.*
- 2) *Measure voltages  $V_{T6}$ ,  $V_{T7}$ ,  $V_{T8}$  and current  $A_{T1}$ .*
- 3) *Start energy transfer with the procedure specified by the EV supply equipment manufacturer.*
- 4) *Confirm that the operating point is at OP2 as specified in Figure 133.*
- 5) *Preconditions for the fault condition:*
  - a)  *$R_{T3}$  shall be 150 k $\Omega$ ;*

b)  $U_{T1}$  shall be set in order that, when  $S_{T9}$  is closed,  $V_{T6}$  is

- i)  $-(0,1 \times V_{EVSE\_rated\_max\_sideB})$  if  $V_{EVSE\_rated\_max\_sideB}$  is  $> 500$  V DC, or
- ii)  $-550$  V +  $V_{EVSE\_rated\_max\_sideB}$  if  $V_{EVSE\_rated\_max\_sideB}$  is  $\leq 500$  V DC.

6) Close  $S_{T9}$ .

7) Check that the EV supply equipment performs an error shutdown.

8) Check that  $V_{T6}$  and  $V_{T7}$  are  $< 60$  V DC in 5 s or less after closing  $S_{T9}$ .

NOTE 3 The tests simulate a fault that can either be in the EV supply equipment or EV.

### 6.3.1.113 Shutdown of the EV supply equipment

#### 6.3.1.113.1 General

At the end of the shutdown stage, the EV supply equipment shall reduce the present current at side B to  $\leq 5$  A DC and shall be designed such that the present voltage at side B remains  $\leq 60$  V DC between DC+ and DC–, between DC+ and the protective conductor, and DC– and the protective conductor.

According to ISO 17409:2020, 6.5.2, when unmated, the EV may have a voltage  $> 60$  V DC and  $> 30$  V AC between DC+ and PE, and between DC– and PE.

The IMD or the earth leakage current monitoring device may be used by the EV supply equipment to reduce the voltage at side B to  $\leq 60$  V DC between DC+ and the protective conductor, and DC– to the protective conductor.

#### 6.3.1.113.2 Normal shutdown

Normal shutdown occurs as a result of an intrinsic reaction of the EV or the EV supply equipment or a user interaction, for other reasons than the presence of a failure.

At the end of the normal shutdown sequence, the EV supply equipment shall reduce and maintain:

- the present current at side B  $\leq 5$  A DC, and
- the present voltage at side B  $\leq 60$  V DC between DC+ and DC–, DC+ and the protective conductor, and DC– and the protective conductor.

Further requirements are specified in AA.4.3.5.1, BB.4.5 and CC.3.3.

#### 6.3.1.113.3 Error shutdown

After the error shutdown is triggered by the EV supply equipment, the EV supply equipment shall reduce and maintain:

- the present current at side B  $\leq 5$  A, and
- the present voltage at side B  $\leq 60$  V DC between DC+ and DC–, between DC+ and the protective conductor, and DC– and the protective conductor.

Timing and further requirements to initiate an error shutdown are specified

- for system A, in AA.3.8.1 and AA.4.3.5.2,
- for system B, in BB.5.1, and
- for system C, in CC.3.4.

NOTE The compliance test verifies the shutdown time which consists of performance time plus trigger time as defined in AA.3.8.1, AA.4.3.5.2, BB.5.1 and CC.3.4 where error shutdown is the consequence. The trigger time does not need to be verified provided shutdown time complies with the specific requirement.

#### 6.3.1.113.4 Emergency shutdown

After the emergency shutdown is triggered by the EV supply equipment, the EV supply equipment shall reduce and maintain:

- the present current at side B  $\leq 5$  A in 30 ms or less for system A and system B, and in 20 ms or less for system C, and
- the present voltage at side B  $\leq 60$  V DC between DC+ and DC–, between DC+ and the protective conductor, and DC– and the protective conductor in 1 s or less for system A and system C, and in 500 ms or less for system B.

NOTE 1 The compliance checks the total time, which consists of the timings above plus triggering time as defined in the respective clauses where emergency shutdown is the consequence. The trigger time does not need to be verified provided shutdown time complies with the specific requirement.

Further requirements are specified in AA.4.3.5.3, BB.5.1 and CC.3.4.

*Compliance for system A and system B is checked by the following test.*

*Compliance for system C is checked by CC.7.6.2 and CC.7.6.6.*

*The test setup for system A is shown in Figure 129. The test setup for system B is shown in Figure 130.*

*The test shall be performed according to the following procedure.*

- 1) *Connect the EV supply equipment to a test load with dedicated EV simulator with a test load for each system.*
- 2) *Start energy transfer with the procedure specified by the EV supply equipment manufacturer.*
- 3) *Confirm that  $V_{T8}$  is at the rated maximum voltage of the EV supply equipment at side B and the EV supply equipment is operating at the rated maximum current at side B.*
- 4) *Open the relay for each system as specified below:*
  - *for system A:  $S_{T5}$ ;*
  - *for system B:  $S_{T4}$ .*
- 5) *The EV supply equipment shall trigger and complete an emergency shutdown, displaying a relevant alarm or error information, if any, according to the following:*
  - *for system A, according to AA.3.8.2.*
  - *for system B, according to BB.5.1 and Table BB.3.*

#### 6.3.2 Optional functions for Modes 2, 3 and 4

*Replacement of the title of this subclause:*

#### 6.3.2 Optional functions for Mode 4

##### 6.3.2.1 General

*Replacement:*

The following functions, if provided by the EV supply equipment, shall comply with applicable clauses as given below:

- ventilation during supply of energy according to 6.3.2.2;
- Mode 4 using system C according to 6.3.2.4;
- sleep mode of the EV supply equipment according to 6.3.2.101;

- detection/adjustment of the applicable maximum current of the EV supply equipment at side B according to 6.3.2.102.

Other additional functions may be provided.

NOTE In the following countries, a positive means to prevent unintentional disconnect is required: US.

*Additional subclauses:*

### **6.3.2.101 Sleep mode of the EV supply equipment**

The EV supply equipment may support a sleep mode to minimize power consumption. If a sleep mode is supported, the EV supply equipment shall implement a wake-up function to be woken up by the EV.

For system A, the EV supply equipment shall wake up by receiving the specific CAN ID from the EV.

*Compliance is checked by the following test:*

- 1) Set the EV supply equipment in sleep mode.
- 2) Send a wake-up signal from EV simulator to the EV supply equipment.
- 3) The EV supply equipment shall
  - for system A, communicate CAN message ID: H'708 after receiving H'700 from the EV simulator as indicated in IEC 61851-24:2023, Table A.2 and Table A.3,
  - for system B, under consideration, and
  - for system C, see CC.5.2.

The availability of the wake-up function of the EV supply equipment during a coupling session may depend on conditions defined by the EV supply equipment manufacturer.

### **6.3.2.102 Detection/adjustment of the applicable maximum current of the EV supply equipment at side B**

The EV supply equipment may change the applicable maximum current of the EV supply equipment at side B and shall communicate it to EV via digital communication. The EV should limit the target current of the EV according to the change in the applicable maximum current of the EV supply equipment at side B. The target current of the EV shall be less than or equal to the applicable maximum current of the EV supply equipment at side B.

For specific requirements, see AA.7.2, BB.13 and CC.5.5.

## **7 Communications**

IEC 61851-1:2017, Clause 7, is applicable, except as follows.

### **7.1 Digital communication between the EV supply equipment and the EV**

*Addition:*

Protective measures defined in this document shall not rely on communicated values between the EV supply equipment and the EV.

Annex GG provides general information on the communication and FTP sequence between the EV supply equipment (SECC) and the EV (EVCC).

Requirements on the digital communication for BPT control for system A are specified in Annex AA.

*Additional subclause:*

#### **7.1.101 Basic communication interface**

Typical interfaces of control pilot function on EV supply equipment are specified in Annex AA, Annex BB and Annex CC. Each system carries out control pilot function through the control pilot conductors and terminals specified in IEC 62196-3.

## **8 Protection against electric shock**

IEC 61851-1:2017, Clause 8, is replaced with the following:

*Replacement:*

### **8.101 General provisions**

#### **8.101.1 General**

Requirements for protection against electric shock shall be according to one or more of the following standards, unless otherwise specified in this document:

- IEC 62477-1:2022;
- IEC 62368-1:2023;
- IEC 61439-7:2022.

Additional requirements for system C are shown in CC.4.1.

For the purposes of this document, the EV supply equipment is considered to be a type of PEC equipment.

Hazard based safety models according to IEC 62368-1:2023 may be used to evaluate protection against electric shock.

Protection against electric shock including potential hazards on side B of the EV supply equipment under conditions of intended use and reasonably foreseeable misuse shall be provided by at least one of the following measures:

- basic protection and fault protection, see 8.102 and 8.103;
- enhanced protective provision, see 8.104.

Protection under normal operating conditions is provided by basic protection, and protection under single fault conditions is provided by fault protection.

Specific protective measures for side B are provided in 8.105.

Protection of side A of the EV supply equipment may include an RCD according to 8.105.9.

Specific requirements for protective measures for non-separated EV supply equipment are under consideration.

### 8.101.2 Intended use and reasonably foreseeable misuse

The EV supply equipment shall meet the following requirements, considering intended use and reasonably foreseeable misuse:

- hazardous-live-parts shall not be accessible and accessible-conductive-parts shall not be hazardous live;
- hazardous voltage shall not be disconnected with the vehicle connector.

*Compliance for hazardous-live-parts is checked according to 8.102, 8.103 and 8.104.*

*Compliance for hazardous voltage is checked according to 6.3.1.103.*

### 8.101.3 Limitation of touch current or touch voltage

Under normal operating conditions and single fault conditions, an ordinary person shall be protected against a harmful electric shock by either

- limiting the touch current and the touch energy, or
- limiting the touch voltage.

Body impedance corresponding to water wet conditions in IEC 60479-1:2018, 3.1.8, shall be considered under the normal operation conditions and single fault conditions.

*Compliance for hazardous-live-parts is checked according to 8.102, 8.103, 8.104 and 8.105.*

NOTE The skin of a sweating person or a person after immersion in sea water is not considered.

### 8.101.4 Threshold of perception and startle reaction

Protective measures shall be provided to prevent startle reactions during intended use and reasonably foreseeable misuse, before, during and after a communication session, under normal conditions and during single fault conditions. During the normal operating conditions, perception may be possible.

NOTE 1 Curve a (boundary between AC-1/AC-2, DC-1/DC-2) of IEC 60479-1:2018, Table 11 and Table 13, corresponds to the threshold of startle reaction in this document.

NOTE 2 The intended use includes, but is not limited to, handling of energy transfer accessories such as side B cable assembly, vehicle connector and vehicle inlets, initiating a communication session, ending a communication session, an ordinary person or animal entering or exiting the EV, opening and retrieving an item from the EV trunk/boot or other storage areas, touching the vehicle chassis, and touching exposed metal parts of the EV supply equipment.

For the current path, finger at the vehicle connector to feet, and hand at the vehicle chassis to feet, shall be considered under normal and single fault conditions. The current path from hand to hand shall be considered for special protection provisions. See the IEC 60479 series.

Protection by means of limitation of touch current shall be provided, such that a steady-state touch current flowing between simultaneously accessible conductive parts shall be less than

- 0,5 mA AC/2 mA DC under normal operation, and
- 3,5 mA AC/10 mA DC under single fault condition.

*Compliance is checked by measurement according to 12.6.*

The EV supply equipment shall limit the discharge energy, such that discharge energy shall be less than

- 5  $\mu$ J under normal operation, and
- 0,5 mJ under single fault condition.

NOTE 3 The values are based on IEC 61140:2016, 5.2.7 b).

For relevant requirement, see 8.105.4.

*Compliance is checked by design review.*

Special protection shall be provided such that, in case of a failure of the provision for basic protection and a simultaneous failure of the provision for fault protection of side B, the steady-state touch current is less than or equal to curve b, the upper boundary of the DC–2 zone, as specified in IEC 60479-1:2018, Figure 22 and Table 13.

Special protection shall be provided such that, in case of a failure of the provision for basic protection and a simultaneous failure of the provision for fault protection of side B, the touch current is less than or equal to the  $c_1$  curve as specified in IEC 60479-2:2019, Figure 23, and IEC 60479-1:2018, Figure 22, respectively.

The following parameters shall be used:

- a human body impedance of 575  $\Omega$ ;
- the maximum Y-capacitances of the EV according to ISO 17409:2020;
- a worst-case asymmetric leakage resistance of the EV where energy transfer is still possible.

*For system B, compliance is checked by design review according to Annex HH.*

*For system A and system C, compliance is checked by the following test.*

*The test setup for system A is shown in Figure 129. The test setup for system C is shown in Figure 131.*

*Pre-conditions for the test:*

- *For all systems:*
  - a) *The fault resistance is 575  $\Omega$ , to represent the human body impedance.*
  - b) *The EV supply equipment manufacturer shall specify the operating point at which the EV supply equipment has the maximum energy stored in the Y-capacitance between DC+/DC– and the protective conductor.*
  - c) *The test setup shall have the maximum EV Y-capacitance ( $C_{T7}/ C_{T8}$ ) for the operating point specified in step b), as specified by ISO 17409.*

NOTE 4 The EV supply equipment can switch in more PECs depending on the current demand, and/or put modules in series or parallel due to the voltage demand. This can influence the total Y-capacitance and leakage current.

- *Additionally, for system A:*
  - d) *Set the test load and target current of the EV  $I_{Req}$  (see Clause AA.5), of the EV simulator so that the EV supply equipment operates at the operating point specified in precondition b).*
- *Additionally, for system C:*
  - e) *Approach the test point as specified in step b) according to CC.7.4.*

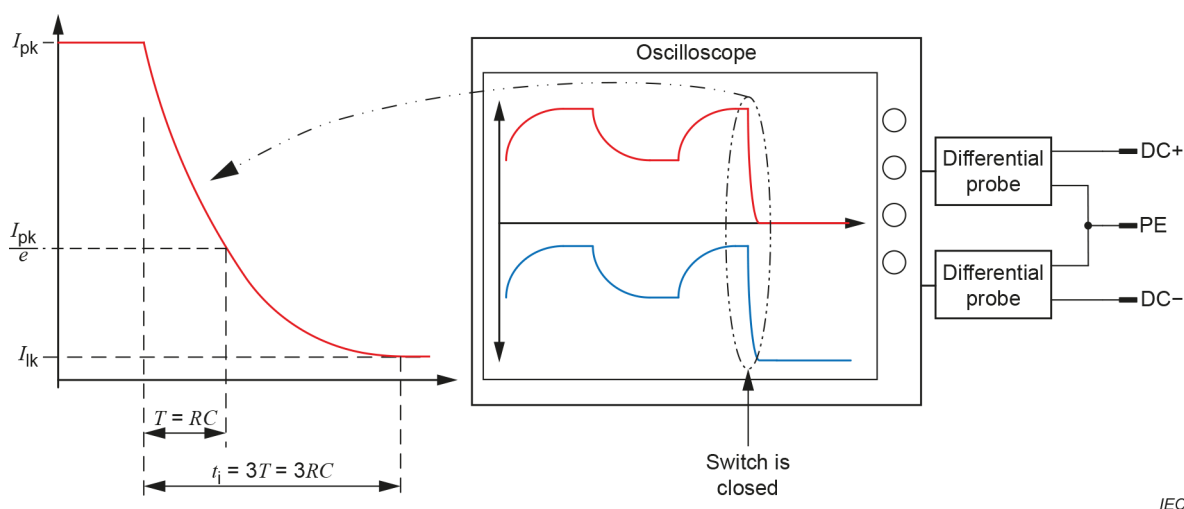

**Figure 106 – Measurement of the touch leakage current**

The test shall be executed as follows:

- 1) Close  $S_{T13}$ .
- 2) Determine the threshold of  $R_{T6}$  where the earth leakage current monitoring device (for system A) or IMD (for system C) trips.
- 3) Add  $\leq 10\%$  to the trip value for  $R_{T6}$  in order to continuously charge with the maximum allowed asymmetric leakage resistance.
- 4) Wait until the operating point defined in step b) is reached.
- 5) Apply the defined fault resistance  $R_{T5}$  at the maximum voltage by closing  $S_{T11}$ .

NOTE 5 For system C, the maximum voltage includes the voltage superimposed by the IMD.

- 6) The currents through  $R_{T5}$  and  $R_{T6}$  can be determined by measuring the voltage over the known resistance  $R_{T5}$ .
- 7) Measure the discharge curve with an oscilloscope and extract the time constant of the discharge event  $t_i = 3RC$  and determine  $I_{RMS} = \frac{I_{peak}}{\sqrt{6}}$ . See Figure 106.
- 8) Measure the steady state leakage current  $I_{RT5}$ .
- 9) Repeat the test by:
  - closing  $S_{T11}$  in step 1),
  - determining the threshold with  $R_{T5}$  in step 2),
  - applying the defined fault resistance  $R_{T6}$  by closing  $S_{T13}$  in step 5),
  - measuring the voltage over  $R_{T6}$  in step 6), and
  - measuring  $I_{RT6}$  in step 8).

NOTE 6 The dynamic behaviour of the IMD (for example, switching) can influence this test; it can be necessary to repeat the test a few times to ensure that worst case condition is tested.

10) Check the expected results:

- a) The steady-state leakage current  $I_{RT5}$  and  $I_{RT6}$  measured in step 8) are less than or equal to the DC-2 limit (line b) in IEC 60479-1:2018, Figure 22 and Table 13.

NOTE 7 In steady-state, the DC2 limit is 25 mA.

- b) The points  $(I_{RMS}, t_i)$  measured in step 7) are less than or equal to the  $C_1$  limit in IEC 60479-2:2019, Figure 23, and IEC 60479-1:2018, Figure 22.

NOTE 8 See Figure HH.4.

## **8.102 Basic protection**

### **8.102.1 General**

Basic protection in the EV supply equipment is employed to prevent persons from touching hazardous live parts. Basic protection shall be provided by one or more of the measures given in 8.102.2, 8.102.3, 8.102.4, and 8.102.5.

### **8.102.2 Protection by means of basic insulation of live parts**

Protection by means of basic insulation of live parts in the EV supply equipment shall be according to IEC 62477-1:2022, 4.4.3.2.

Basic insulation shall be provided by solid insulation or clearance and/or creepage distance.

Any accessible conductive part is considered to be a hazardous live part if not separated from the live parts by required insulation.

Basic insulation shall be designed and tested to withstand the impulse voltages and temporary overvoltages for the circuits to which they are connected.

*Compliance is checked by inspection and test.*

*Test shall be conducted according to Table 28 of IEC 62477-1:2022, 5.2.3.4 (only for circuits connected directly to mains supply, see 6.3.1.112), and IEC 62477-1:2022, 5.2.3.2.*

### **8.102.3 Protection by means of enclosures or barriers**

Protection by means of enclosures or barriers in the EV supply equipment shall be according to 8.105.4 and 12.4.

Enclosures shall be suitable for use in their intended environments.

The EV supply equipment shall have adequate mechanical strength and shall be so constructed that no hazard occurs when subjected to intended use and expected misuse over the expected lifetime in accordance with 12.107.

It shall only be possible to open enclosures or remove barriers

- with the use of a tool or key, or
- after de-energization of hazardous live parts.

For additional requirements, see 12.107.

### **8.102.4 Protection by means of limitation of voltage**

Basic protection by the provision of limitation of voltage shall be fulfilled where the following conditions are met:

- a) steady-state touch voltage under normal operation is less than the values in Table 110;
- b) steady-state touch voltage under single fault condition is less than the values in Table 111;
- c) a non-recurring DC touch voltage under normal operation is less than the limit in Table 110;
- d) a non-recurring DC touch voltage for fingertip to feet under single fault condition is less than the limit in Figure 107;

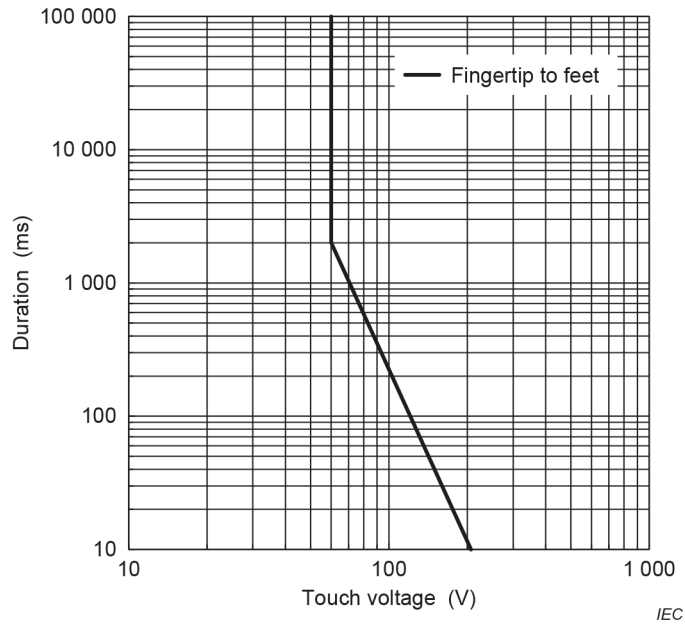

**Figure 107 – Touch time – DC voltage under single fault condition (water wet, fingertip to feet)**

e) the voltage is supplied by one of the following sources:

- 1) a safety isolating transformer for the auxiliary circuit including control pilot;

NOTE Safety isolating transformers are those that comply with IEC 61558-2-6.

- 2) a source of voltage providing a degree of safety equivalent to that of a safety isolating transformer;
- 3) electrochemical (for example, battery system).

**Table 110 – Touch voltage under normal operation**

Body contact area	AC (RMS)	DC
Part of body	Basic protection	
Hand		
Fingertip	12 V	30 V
NOTE The values are based on a current path from the contact area of the body to feet, with the person in standing position.		

**Table 111 – Touch voltage under single fault conditions**

Body contact area	AC (RMS)	DC
Part of body	Fault protection	
Hand		
Fingertip	30 V	60 V
NOTE 1 The values are based on a current path from the contact area of the body to feet, with the person in standing position and in water wet conditions.		
NOTE 2 If these values cannot be met under single fault conditions, protective separation is needed.		

*Compliance is checked by inspection and measurement.*

### **8.102.5 Protection by means of limitation of steady-state touch current**

Limitation of steady-state touch current is a provision whereby touch current is limited to non-hazardous values. The limits are provided in 8.101.4.

The protective impedance limiting the touch current shall comply with IEC 62477-1:2022, 4.4.5.5.

*Compliance is checked by test in IEC 62477-1:2022, 4.4.5.5.*

## **8.103 Fault protection**

### **8.103.1 General**

Fault protection provides protection against bodily harm due to contact with hazardous electrical energy during and after failure of the basic protection.

Fault protection shall be provided by one or more of the following measures:

- protective equipotential bonding in 8.103.2 in combination with the protective conductor;
- automatic disconnection of supply in 8.103.4;
- supplementary insulation in 8.103.5;
- electrically protective screening in 8.103.6.

Fault protection shall be independent and additional to those for basic protection.

### **8.103.2 Protective-equipotential-bonding**

Protective-equipotential-bonding is a provision whereby items are bonded together to avoid hazardous touch voltages.

Protective-equipotential-bonding in the EV supply equipment shall be according to IEC 62477-1:2022, 4.4.4.2.

*Compliance is checked by visual inspection and tests in accordance with IEC 62477-1:2022, 4.4.4.2.*

### **8.103.3 Effective protective conductor continuity between the enclosure and the external protective circuit**

Exposed conductive parts of the EV supply equipment shall be effectively connected to the terminal for the external protective conductor, and the resistance from the conductive part to the terminal of the external protective conductor shall be  $\leq 0,1 \Omega$ .

*Compliance is checked by the following test.*

- 1) *Make verification using a resistance measuring instrument which can drive a current of  $\geq 10$  A (AC or DC). Pass the current between each exposed conductive part and the terminal for the external protective conductor.*
- 2) *Confirm that the resistance is  $\leq 0,1 \Omega$ .*

NOTE Routine testing can be performed according to IEC 62477-1:2022, 5.2.3.11.4.

#### **8.103.4 Automatic disconnection of supply**

Automatic disconnection of supply in the EV supply equipment shall be according to IEC 62477-1:2022, 4.4.4.4, except as follows.

- The protective device may be provided in any suitable upstream part of the installation or the EV supply equipment. The EV supply equipment manufacturer shall give appropriate information for the installation of external protection. The information may be provided in a circuit diagram.

*Compliance is checked by inspection and measurement in accordance with IEC 62477-1:2022, 4.4.4.4.*

#### **8.103.5 Supplementary insulation**

Supplementary insulation in the EV supply equipment shall be according to IEC 62477-1:2022, 4.4.4.5.

*Compliance is checked by inspection.*

#### **8.103.6 Electrically protective screening**

Electrically protective screening in the EV supply equipment shall be according to IEC 62477-1:2022, 4.4.4.7. Electrically protective screening shall consist of a conductive screen interposed between hazardous-live-parts of the EV supply equipment and the part being protected, whereby the screen is separated from live parts by at least basic insulation.

The protective screen shall

- be connected to the protective-equipotential-bonding system of the EV supply equipment, and that interconnection shall comply with the requirements of IEC 62477-1:2022, 4.4.4.2, and
- comply with the requirements for elements of the protective-equipotential-bonding system according to IEC 61140:2016, 5.3.3.3, 5.3.3.4 and 5.3.3.5.

*Compliance is checked by inspection and tests in accordance with IEC 62477-1:2022, 4.4.4.3.*

### **8.104 Enhanced protective provision**

#### **8.104.1 General**

An enhanced protective provision provides both basic protection and fault protection according to one or more of the provisions specified in 8.104.2 and 8.104.3.

#### **8.104.2 Double or reinforced insulation**

Double insulation in the EV supply equipment shall be according to IEC 62477-1:2022, 4.4.5.2.

Reinforced insulation in the EV supply equipment shall be according to IEC 62477-1:2022, 4.4.5.3.

NOTE In the following country, additional requirements for equipment employing a system of double and or reinforced insulation are required: US.

*Compliance is checked by inspection and tests in accordance with of IEC 62477-1:2022, 4.4.5.2 and 4.4.5.3.*

### 8.104.3 Protective separation between circuits

Protective separation between circuits in the EV supply equipment shall be according to IEC 62477-1:2022, 4.4.5.4.

For side B, the steady-state touch current shall be less than or equal to curve b, the upper boundary of the DC-2 zone, as specified in IEC 60479-1:2018, Figure 22 and Table 13. Additionally, the touch current shall be less than or equal to the  $c_1$  curve as specified in IEC 60479-2:2019, Figure 23, and IEC 60479-1:2018, Figure 22, respectively. See 8.101.4.

*Compliance is checked by inspection and tests in accordance with IEC 62477-1:2022, 4.4.5.4.*

## 8.105 Requirements for separated EV supply equipment

### 8.105.1 General

The side B of the EV supply equipment shall be designed according to the provisions against electric shock, for basic protection, fault protection and special protection as specified in Table 112.

**Table 112 – Safety provisions for protection against electric shock for EV supply equipment at side B**

Provisions for basic protection Protection in absence of a fault	Provisions for fault protection Protection in case of a fault	Provisions for special protection
Basic insulation <sup>g</sup> : <ul style="list-style-type: none"> <li>– (solid) basic insulation</li> <li>– basic insulation by air</li> <li>– inside barriers or enclosures</li> </ul>	For class I <sup>j</sup> portions: <ul style="list-style-type: none"> <li>– Protective separation between side A and side B <sup>a, c</sup> (8.105.5)</li> <li>– Protective equipotential bonding to accessible conductive parts (IEC 61140:2016, 5.3.3.2), for example, for metal housing <sup>a</sup> (8.105.1), in combination with:                             <ul style="list-style-type: none"> <li>• for system A (AA.3.8.2): disconnection of the EV by triggering an emergency shutdown upon loss of protective equipotential bonding <sup>h</sup>;</li> <li>• for system B (BB.14) and system C (CC.4.6): mechanical robustness of the equipotential bonding by both                                     <ul style="list-style-type: none"> <li>i) minimum cross section of the protective conductor, and</li> <li>ii) using a vehicle coupler according to IEC 62196-1, IEC 62196-3 and IEC 62196-3-1.</li> </ul> </li> </ul> </li> <li>– Electrically protective screening (shielding) between hazardous-live-parts and accessible surfaces of parts of insulating material (8.105.5).</li> </ul> For class II <sup>j</sup> portions: Double or reinforced insulation (8.105.5). Accessible SELV/PELV circuits: Protective separation between side B and the SELV/PELV circuit, or basic insulation and all of the conditions given in footnote <sup>e</sup> (8.105.5).	<ul style="list-style-type: none"> <li>– Protective separation between side A and side B <sup>a, c</sup> (8.105.5)</li> <li>– Continuous continuity checking of the protective conductor and de-energization upon loss of continuity <sup>a, d</sup> (6.3.1.2)</li> <li>– For system B, the protective equipotential bonding withstands the short-circuit energy <sup>i</sup> (8.105.11, Clause BB.14)</li> <li>– Perform an error shutdown when an asymmetric or symmetric insulation fault to protective conductor occurs, detected by the IMD or earth leakage current monitoring device <sup>a, e</sup> (8.105.1)</li> <li>– Multiple side Bs shall be separated from each other by basic insulation <sup>a, f</sup> (8.105.1)</li> <li>– Limitation of steady-state touch current (B) and impulse current (<math>C_1</math>) <sup>a</sup> (8.101.4)</li> <li>– Limitation of Y-capacitance to &lt; 500 nF per rail <sup>a, b</sup> (8.105.3)</li> </ul>

- a The EV supply equipment shall provide this provision in order to support the protective provisions of an EV that is designed entirely as class I equipment or that contains portions that are designed as class I equipment. This applies even if the EV supply equipment itself is designed entirely as class II equipment.
- b The EV supply equipment shall provide this provision in order to support the protective provisions of an EV that uses limitation of touch energy as provision for fault protection in accordance with ISO 6469-3:2018 and ISO 17409:2015.
- c This single provision serves simultaneously as:
- fault protection for class I equipment, or class I portions of the system, in case of a failure of the basic protection between live parts and accessible conductive parts, and
  - special protection for class II equipment, or class II portions of the system, in case of a failure of the provision for basic protection and a simultaneous failure of the provision for fault protection.
- d This provision serves simultaneously
- to prevent hazards caused by "blinding" of the IMD/leakage current monitoring device, and
  - to prevent hazards caused by a loss of equipotential bonding for class I portions of the system.
- e Conditions:
- the PELV circuit is connected to the protective conductor;
  - no hazardous voltage or touch current occurs (see 8.101.3) in the PELV circuit due to an insulation fault between the PELV circuit and the DC circuit;
  - the IMD or earth leakage current monitoring device detects this insulation fault between the PELV circuit and the DC circuit, and triggers an error or emergency shutdown.
- f In order to consider only one EV for calculation of the Y-capacitance ( $C_y$ ) and in order to prevent interference caused by multiple IMDs.
- g For each portion of the EV supply equipment, one of these provisions for basic protection shall be implemented. See also IEC 61140:2016, 5.2.
- h The disconnection of the EV is achieved by opening the EV disconnection device via CP, see Figure AA.1.
- i This short-circuit energy is a consequence of two independent faults, one from DC+ to the protective conductor and one from DC– to the protective conductor, of which one occurs in the EV and the other one occurs in the EV supply equipment.
- j Considering IEC 61140:2016, 7.3 and 7.4.

Requirements for protection against electric shock hazard for separated EV supply equipment are defined for each system in AA.3.1, Clause BB.2, and CC.4.1.

In case the EV supply equipment can supply more than one EV simultaneously, independent protection means (protection against electrical shock, overload and short-circuit protection) for each vehicle connector shall be implemented.

If the EV supply equipment has multiple side B circuits, all the requirements in this document on side B shall apply at each side B circuit individually.

If the EV supply equipment has multiple side B circuits, each side B circuit shall be separated from each other by at least basic insulation.

NOTE 1 This means each side B is not allowed to share a DC+ and/or DC–, with any other side B.

NOTE 2 The protective conductor of each vehicle connector is shared by bonding to the protective conductor of side A, see 8.105.2.

Additional requirements for multi-side B EV supply equipment are specified in Annex FF.

NOTE 3 In the following countries, both separated EV supply equipment and non-separated EV supply equipment must comply with the requirements in national standards: US, CA.

*Compliance is checked by design review.*

### 8.105.2 Equipotential bonding on side B

The EV supply equipment shall provide a protective conductor for side B. This protective conductor shall provide protective equipotential bonding of exposed conductive parts of the EV supply equipment and the EV. This protective conductor shall also be used for earth leakage current monitoring (see AA.3.1.2), insulation resistance check (see BB.2.2 and Clause BB.8), or insulation monitoring (CC.4.1.3), respectively.

The EV supply equipment shall provide this protective conductor to the EV through the appropriate contact of the vehicle connector according to IEC 62196-1, IEC 62196-3 and IEC 62196-3-1.

For system A, the requirement for RPT EV supply equipment is specified in AA.6.1.

The side A protective conductor terminal, if any, shall be bonded to the side B protective conductor. If the supply network provides a protective conductor to the EV supply equipment, this protective conductor shall be bonded to the protective conductor of the side B.

If the supply network does not provide a protective conductor to the EV supply equipment or the protective conductor provided by the supply circuit is not earthed, the user manual shall state that the EV supply equipment is only allowed to be operated by skilled personnel or instructed personnel.

NOTE In the following countries, an ordinary person can operate the RPT EV supply equipment even if the supply circuit (in this case, an EV) and/or the load does not provide an earthed protective conductor, or the earth (ground where the earthing rod of the RPT EV supply equipment can be inserted) is not available nearby: JP.

*Compliance is checked by inspection.*

### 8.105.3 Impedance to protective conductor on side B

When side B is live, the actual total physical insulation resistance of the EV supply equipment between side B live parts (DC+/DC–) to the protective conductor, which will not result in a shutdown, shall limit the touch current within the DC-2 area of IEC 60479-1:2018, Figure 22.

NOTE 1 The actual total physical insulation resistance is a combination of the impedance of all the components within the EV supply equipment and the EV in parallel.

NOTE 2 The measured insulation resistance does not include the internal resistance of the insulation measurement device or earth leakage current monitoring device.

*Compliance is checked according to 8.101.4.*

For system A, an earth leakage current monitor in the EV supply equipment shall detect the first fault, and for system C, an IMD shall detect the first fault and disconnect the supply or perform an error shutdown. The earth leakage current monitoring device and the IMD do not provide fault protection but can prevent a hazardous electric shock as special protection.

NOTE 3 For system B, the EV will perform the insulation monitoring during energy transfer.

The reaction time of IMD or earth leakage current monitoring device shall be according to AA.3.1.2, BB.2.2, BB.8 and CC.4.1.6. The value of the Y-capacitances shall ensure that the reaction time of IMD or earth leakage current monitoring device is less than the limit. In the side B circuit, the Y-capacitance between DC+ and the protective conductor shall be < 500 nF. In the side B circuit, the Y-capacitance between DC– and the protective conductor shall be < 500 nF.

NOTE 4 The side B circuit Y-capacitance requirements for the EV supply equipment result in a total capacitance of 1 µF.

The limitation of stored energy in the Y-capacitors shall not be used as fault protection under single fault condition for the EV supply equipment.

The special protection required in 8.101.4 may be provided by limited impedance between side B live parts (DC+/DC–) and the protective conductor, including the connected EV.

NOTE 5 System A requires the limitation of the Y-capacitance of EVs with battery system voltages to  $\leq 500$  V DC, such that the total stored energy per side B live part (DC+/DC–) to protective conductor of the EV supply equipment mated to the EV is  $\leq 0,2$  J under the worst-case scenario.

*Compliance to the Y-capacitance limit is checked by the following test.*

*The test setup for system A is shown in Figure 129. The test setup for system C is shown in Figure 131.*

*Pre-conditions for the test:*

- *For all systems:*
  - a) *The fault resistance is 1 k $\Omega$ , a low enough resistance to cancel out the influence of other circuit resistances. Set  $R_{T5}$  or  $R_{T6}$  to the fault resistance value.*
  - b) *The EV supply equipment manufacturer shall specify the operating point at which the EV supply equipment has the maximum energy stored in the Y-capacitance between DC+/DC– and the protective conductor.*
  - c) *The Y-capacitances ( $C_{T7}/C_{T8}$ ) of the EV simulator shall be known.*

NOTE 6 The EV supply equipment can switch in more PECs depending on the current demand, and/or put modules in series or parallel due to the voltage demand. This can influence the total Y-capacitance and leakage current.

- *Additionally, for system A:*
  - d) *Set the test load and target current of the EV  $I_{Req}$  (see Clause AA.5) of the EV simulator so that the EV supply equipment operates at the operating point specified in step b).*
- *Additionally, for system C:*
  - e) *Approach the test point as specified in step b) according to CC.7.4.*

*The test shall be executed as follows.*

- 1) *Wait until the EV supply equipment reaches the operating point specified at precondition b).*
- 2) *Close  $S_{T11}$  or  $S_{T13}$  to apply the fault resistance ( $R_{T5}$  or  $R_{T6}$ ).*
- 3) *Measure the discharge curve of the capacitance. By extracting the time constant of the discharge event, the total capacitance can be determined (Formula (2)). See Figure 106.*

$$C = \frac{t}{R_{T\_Fault}} \quad (2)$$

where

$C$  is the Y-capacitance, expressed in Farad;

$R_{T\_Fault}$  is the fault resistance, expressed in Ohms;

$t$  is the discharge time, expressed in seconds;

- 4) *Check that, after subtracting the Y-capacitance of the EV simulator (precondition c)), the maximum total parallel Y-capacitance is  $< 1$   $\mu$ F.*

#### **8.105.4 Degrees of protection against access to hazardous-live-parts**

Degrees of protection for enclosures of EV supply equipment shall fulfil at least IPXXC.

Compliance is checked by inspection and measurement.

**8.105.5 Insulation barriers**

The EV supply equipment shall have insulation barriers as shown in Figure 108. The EV supply equipment shall provide the minimum protective measures as defined in Table 113.

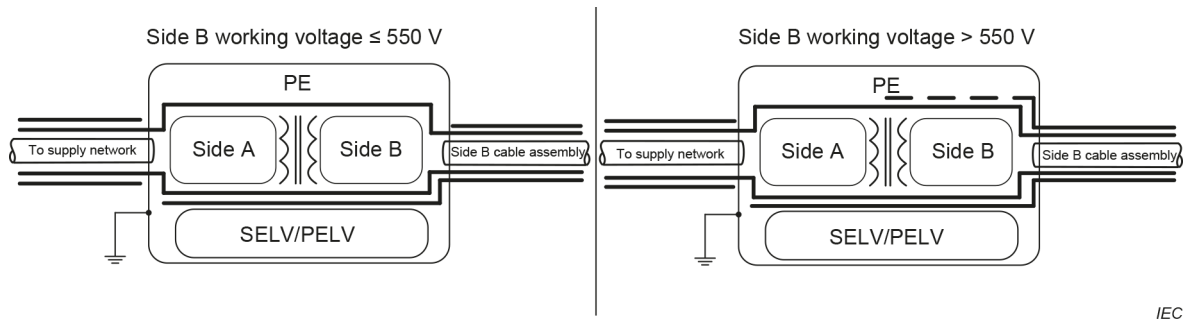

IEC

**Key**

- PE                      protective conductor
- (single line)        basic insulation
- (double lines)      double insulation or basic insulation and electrically protective screening (shielding) or reinforced insulation
- (dashed line)        basic insulation or double/reinforced insulation. See Table 113.

NOTE Threshold of 550 V DC is due to backward compatibility with IEC 61851-23:2014.

**Figure 108 – Insulation barriers**

Table 113 gives the required property (with respect to protection) of barriers between the type of circuits given in the first column of Table 113 and the type of circuits, or persons, given in the first row of Table 113.

**Table 113 – Minimum protective measures**

	Side B	SELV/PELV	Protective conductor	Ordinary person
Side A	Protective separation	Protective separation	Basic insulation <sup>a</sup>	<ul style="list-style-type: none"> <li>– Double/reinforced insulation, or</li> <li>– Basic insulation and electrically protective screening (shielding), or</li> <li>– A combination of both</li> </ul>
Side B	n.a	Protective separation <sup>b</sup>	For a working voltage $\leq 550$ V DC: Basic insulation For a working voltage $> 550$ V DC: <ul style="list-style-type: none"> <li>– Basic insulation, or</li> <li>– Double/reinforced insulation<sup>c</sup></li> </ul>	<ul style="list-style-type: none"> <li>– Double/reinforced insulation, or</li> <li>– Basic insulation and electrically protective screening (shielding), or</li> <li>– A combination of both</li> </ul>
SELV	n.a	n.a	Functional insulation <sup>d</sup>	None
Protective conductor	n.a	n.a	n.a	None
<p><sup>a</sup> Local regulations may require double insulation. In some countries, extra monitoring of protective conductor is required when using basic insulation. For some systems, for example, TT systems, double insulation to protective conductor is required up to the RCD, if one is installed in the EV supply equipment.</p> <p><sup>b</sup> In accordance with IEC 62477-1:2022, Table 2 and 4.4.5.5, basic insulation between side B and PELV is allowed if all of the following conditions are met:</p> <ul style="list-style-type: none"> <li>– the PELV circuit is connected to the protective conductor;</li> <li>– no hazardous voltage or touch current occurs (see 8.101.3) in the PELV circuit due to an insulation fault between the PELV circuit and the DC circuit;</li> <li>– the IMD or earth leakage current monitoring device detects this insulation fault between the PELV circuit and side B, and triggers an error or emergency shutdown.</li> </ul> <p><sup>c</sup> If there is a part of the side B circuit with a working voltage <math>&gt; 550</math> V DC and a fault to the protective conductor will cause an offset between side B live parts (DC+/DC-) to protective conductor <math>&gt; 110</math> % of the present voltage at side B, double/reinforced insulation is required between this part and the protective conductor. See 6.3.1.112.2.</p> <p>NOTE Threshold of 550 V DC is due to backward compatibility with IEC 61851-23:2014.</p> <p><sup>d</sup> If SELV is not connected to the protective conductor, a 500 V AC RMS test voltage may be applied to test the insulation.</p>				

Outside of a fire enclosure, the live parts (DC+/DC-) of the side B circuit shall be separated by double or reinforced insulation from each other and other circuits.

*Compliance is checked by inspection.*

### 8.105.6 Stored energy

#### 8.105.6.1 Disconnection of plug-and-cable-connected EV supply equipment

For EV supply equipment that is plug-and-cable-connected at side A, where the connection pins are accessible after unplugging, 1 s after disconnecting the standard plug from the standard socket-outlet, for example, as described in IEC 60309-1, the voltage between any combination of accessible contacts of the standard plug shall be  $\leq 60$  V DC and  $\leq 12$  V AC (RMS) or the stored energy available shall be  $< 0,5$  mJ.

*Compliance is checked by inspection and by the test method in IEC 62368-1:2023, 5.5.2.2, measured 1 s after the disconnection of the plug.*

NOTE Requirements for the EV are specified in ISO 17409:2020.

### 8.105.6.2 Loss of supply voltage to permanently-connected EV supply equipment

The voltage between any side A live parts or between any side A live part and the protective conductor, when measured at the side A terminals of the EV supply equipment, shall be  $\leq 60$  V DC and  $\leq 12$  V AC (RMS) or the stored energy shall  $\leq 0,5$  mJ in 5 s or less after disconnecting the EV supply equipment from the live supply network.

*Compliance is checked by inspection and by the test method in IEC 62368-1:2023, 5.5.2.2, measured 5 s after disconnecting the EV supply equipment from the live supply network.*

### 8.105.7 Disconnection from vehicle

If the present voltage between any contacts at the vehicle connector is  $> 60$  V DC or  $> 12$  V AC (RMS) during energy transfer, the EV supply equipment shall reduce the voltage between any contacts to  $\leq 60$  V DC and  $\leq 12$  V AC (RMS) in 1 s or less after un-mating the vehicle connector from the vehicle inlet.

The voltage shall be measured at the unmated vehicle connector.

*Compliance shall be checked according to the following procedure.*

*The test setup for system A is shown in Figure 129. The test setup for system B is shown in Figure 130. The test setup for system C is shown in Figure 131.*

- 1) *Connect the EV supply equipment to a test load with a dedicated EV simulator for the system under test.*
- 2) *Start a communication session with the procedure specified by the EV supply equipment manufacturer.*
- 3) *Check that  $V_{T8}$  at the rated maximum voltage of the EV supply equipment at side B.*
- 4) *Measure  $V_{T6}$ ,  $V_{T7}$  and  $V_{T8}$  continuously.*
- 5) *Stop the communication session based on the stop sequence defined by each system.*
- 6) *The test is passed if the voltage values  $V_{T6}$ ,  $V_{T7}$  and  $V_{T8}$  are  $\leq 60$  V DC in 1 s or less after disconnecting all the signal lines or the connector-latch circuit, if any.*

### 8.105.8 Protective (earthing) conductor from the supply network

The protective (earthing) conductor and the protective conductor from the supply network shall be of sufficient rating according to the requirements of IEC 60364-5-54:2011, 543.1.2.

NOTE In the following countries, the size and rating of the protective earthing conductor are determined by national codes and regulations: CA, US, JP.

The EV supply equipment shall provide either

- a protective (earthing) conductor from the side A earthing terminal of the supply network to the EV, or
- a protective conductor from the EV supply equipment to the EV, if fault protection is based on protective separation. See requirements in 8.105.11.

For permanently connected EV supply equipment, protective (earthing) conductors shall not be switched.

Protection class II EV supply equipment shall have a lead-through protective conductor with double insulation or reinforced insulation for the protective conductor bonded to the vehicle chassis.

*Compliance is checked by inspection.*

### 8.105.9 Residual current protective devices

The EV supply equipment intended for fixed installation may rely on RCD(s) incorporated in the EV supply equipment and/or provided upstream by the installation as defined in the installation manual of the EV supply equipment and relevant circuit diagrams.

Plug and cable EV supply equipment shall be provided with RCD(s) within the EV supply equipment enclosure or on the cable or the plug, and double insulation to the protective conductor is required between the plug and any parts not protected by RCD(s).

RCDs incorporated in EV supply equipment enclosure, if any, shall be at least of type A and comply with one of the following standards: IEC 61008-1, IEC 61009-1, IEC 60947-2 or IEC 62423.

RCDs incorporated on the cable, if any, shall be at least of type A and comply with IEC 61540.

RCDs shall disconnect all live conductors.

NOTE 1 In the following countries, the RCD shall be located in 0,3 m or less of the plug of the EV supply equipment or in the plug: US, CA.

The EV supply equipment manufacturer shall check compatibility with RCDs incorporated in the EV supply equipment, or to be provided by the installation, by simulation or calculation of current in the protective conductor under normal and single fault conditions according to the guideline provided in IEC 62477-1:2022, Annex H.

In case more than one supply networks are connected to the side A of the EV supply equipment, each connection to a supply network shall comply to the requirements in 8.105.9.

Plug and cable EV supply equipment shall always be designed such that under normal and fault conditions any resulting DC component of the current in the protective conductor is  $\leq 6$  mA DC.

NOTE 2 Limitation of DC component of the current in the protective conductor can be achieved by

- double or reinforced insulation of the circuit that can cause a DC leakage current to any other circuit and protective conductor, or
- DC leakage detection that disconnects the circuit that causes excessive DC leakage current. For example, adding an RDC-DD according to IEC 62955 inside the EV supply equipment.

*Compliance is checked by inspecting the construction and documents provided by the EV supply equipment manufacturer.*

### 8.105.10 Safety requirements for auxiliary circuits between the EV supply equipment and the EV

Any auxiliary circuit, which extends beyond the EV supply equipment enclosure for connection with the EV, for example, control pilot circuit, shall be extra low voltage (SELV or PELV) according to IEC 62477-1.

*Compliance is checked by inspection.*

### 8.105.11 Protective conductor dimension cross-sectional area

The protective earthing conductor or protective conductor of side B of the EV supply equipment shall

- comply with the requirements of IEC 60364-5-54:2011, 543.1.2, and
- be designed according to AA.3.1.1, BB.14 or CC.4.6.

NOTE In the following countries, the size and rating of a protective earthing conductor is specified in national code and regulation: US, CA.

For system A and system C, the prospective fault current is equivalent to the first fault current for a fault of negligible impedance between the side B live parts (DC+/DC–) and the protective conductor.

For system B, the prospective fault current is equivalent to the rating of the protective devices. See 13.101.

*Compliance is checked by inspection and measurement.*

## **9 Conductive electrical interface requirements**

IEC 61851-1:2017, Clause 9, is applicable, except as follows.

### **9.1 General**

*Replacement:*

The physical conductive electrical interface requirements between the EV and the EV supply equipment are defined in IEC 62196-3 or IEC TS 62196-3-1.

### **9.5 Functional description of the DC interface**

*Replacement:*

General requirements and ratings shall be in accordance with the requirements specified in IEC 62196-3 or IEC TS 62196-3-1.

### **9.7 Wiring of the neutral conductor**

*Replacement:*

Wiring instructions shall be provided in the installation manual (see 16.1).

*Additional subclause:*

#### **9.101 Avoidance of breaking under load**

The vehicle couplers are not intended for breaking under load. Un-mating shall not take place under load under normal operation condition, by latching the vehicle connector to the vehicle inlet.

In addition to the latching mechanism defined in 6.3.1.103, in case of an unintended un-mating of the vehicle coupler, the present current at side B shall be reduced in a defined time or less to contain a possible electric arc within the vehicle coupler housing. The time to reduce the present current at side B shall comply with the values specified in AA.3.8.2, BB.5, CC.4.3 and CC.4.4, using a speed of separation of the vehicle connector of  $0,8 \text{ m/s} \pm 0,1 \text{ m/s}$  according to IEC 62196-1.

Un-mating the vehicle coupler in case of a fault of the latching function shall be detected by the loss of electrical continuity of pilot circuit(s), for example, control pilot, proximity circuit, to mitigate electrical arcing and shock hazards by performing an emergency shutdown.

*Compliance is checked by the test in 6.3.1.113.4.*

The system specific requirements for breaking capacity and system redundancy are defined in AA.3.6 and AA.3.8.2 for system A, BB.5 for system B, and CC.4.3 and CC.4.4 for system C.

## 10 Requirements for adaptors

### Replacement:

Vehicle adapters between the vehicle connector and the vehicle inlet shall be used if specifically designated and approved by the vehicle manufacturer or by the EV supply equipment manufacturer. The vehicle adapters can be designed in accordance with IEC TS 62196-7<sup>4</sup> and “CHAdeMO 3.0 inlet adapter performance confirmation sheet” published by CHAdeMO Association<sup>5</sup>; other national requirements can apply.

Such vehicle adapters shall comply with the requirements of this document and IEC 62196-3. The vehicle adapters shall be marked to indicate the specific conditions of use allowed by the vehicle adapter manufacturer, for example, IEC 62196-1, IEC 62196-3 and IEC 62196-3-1, IEC 62196-7.

NOTE 1 Revision of the requirement “Vehicle adapters shall not be used to connect a vehicle connector to a vehicle inlet” in IEC 61851-1:2017 is under consideration.

NOTE 2 IEC TS 62196-7 allows vehicle adapters to connect a vehicle connector of configuration AA or configuration BB as specified in IEC 62196-3 to a vehicle inlet according to IEC PAS 63454 and of configuration GG (to be specified in IEC 62196-3).

The vehicle adapters shall be of any of the following construction types (see Figure 109):

- Type A: A portable vehicle adapter containing an adapter inlet and an adapter connector in the same housing.
- Type B: A portable vehicle adapter containing an adapter inlet and an adapter connector in different housings, wired/connected together by a cable.
- Type C: A vehicle adapter containing an adapter inlet and an adapter connector in the different housings wired by a cable, with the housing of the adapter inlet fixed to the EV supply equipment.

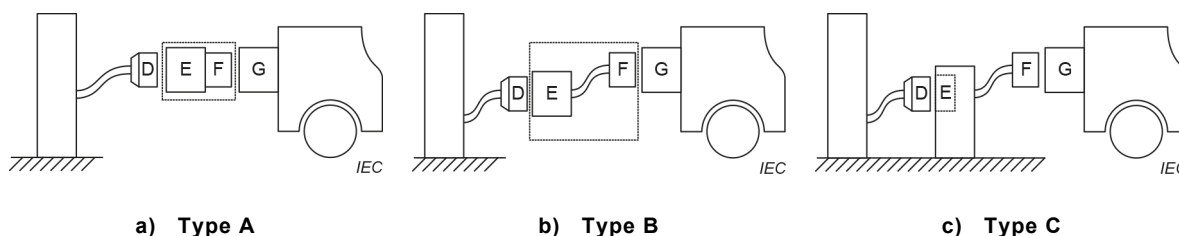

### Key

D	vehicle connector	F	adapter connector
E	adapter inlet	G	vehicle inlet

NOTE Construction types are based on IEC TS 62196-7.

**Figure 109 – Construction types of vehicle adapters**

<sup>4</sup> Under preparation. Stage at the time of publication: IEC TS CD 62196-7:2023.

<sup>5</sup> CHAdeMO is the trademark of the CHAdeMO Association. This information is given for the convenience of users of this document and does not constitute an endorsement by IEC of the specification named. Equivalent specifications may be used if they can be shown to lead to the same results.

## 11 Cable assembly requirements

IEC 61851-1:2017, Clause 11, is applicable, except as follows.

### 11.1 General

*Replacement:*

The EV supply equipment shall be equipped with a non-detachable side B cable assembly.

The side B cable assembly shall be provided with a cable that is suitable for the application according to IEC 62893-4-1:2020 and for cable assemblies with thermal transport device according to IEC 62893-4-1:2020.

### 11.6 Strain relief

*Replacement of the 2<sup>nd</sup> paragraph:*

For case C, the strain relief at the EV supply equipment shall be in accordance with 11.6.101.

*Additional subclauses:*

#### 11.6.101 Strain relief of the EV supply equipment's side B cable assembly

Side B cable assemblies shall be connected to the enclosure of the EV supply equipment so that the conductors are relieved from strain, including twisting, where they are connected to the terminals or terminations, and that their covering is protected from abrasion.

The construction shall ensure that the side B cable assembly cannot touch accessible metal parts or internal metal parts, for example, cable anchorage screws, if these are electrically connected to accessible metal parts, unless the accessible metal parts are connected to the internal protective earth terminal.

The design of the cable anchorage shall be such that the anchorage or its components are properly positioned relative to the side B cable assembly when assembled. Cable anchorages shall present no sharp edges to the side B cable assembly and shall be designed in a way that their components shall not be lost when the enclosure of the EV supply equipment is being opened.

Makeshift methods, such as tying the side B cable assembly into a knot or tying the ends with string, shall not be used. Cable anchorages and cable inlets shall be suitable for the different types of flexible side B cable assemblies that may be connected.

If a cable entrance is provided with a sleeve to prevent damage to the side B cable assembly, this sleeve shall be of insulating material and shall be smooth and free from burrs. If a bell-mouthed opening is provided, the diameter at the end shall be at least 1,5 times the diameter of the cable with the largest cross-sectional area to be connected.

Helical metal springs, whether bare or covered with insulating material, are not allowed as side B cable assembly sleeves.

*Compliance is checked by inspection and by the tests in 11.6.102.*

### 11.6.102 Test of the anchorage of the side B cable assembly

The device under test (DUT) is the EV supply equipment. The test shall be performed for each side B cable assembly attached to the DUT according to the test setups in Figure 110 and Figure 111. Any cable management systems for the side B cable assembly shall be removed before the test.

The apparatus for testing the side B cable assembly anchorage shown in Figure 110 shall be set up next to the DUT in such a way that the side B cable assembly points horizontal from the enclosure of the DUT, see Figure 111.

Dimensions in millimetres

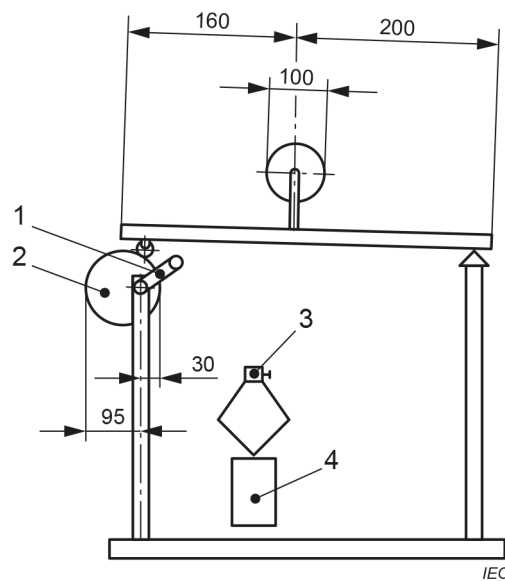

#### Key

1	crank	3	cable fixation
2	eccentric	4	weight

**Figure 110 – Apparatus to test the side B cable assembly anchorage**

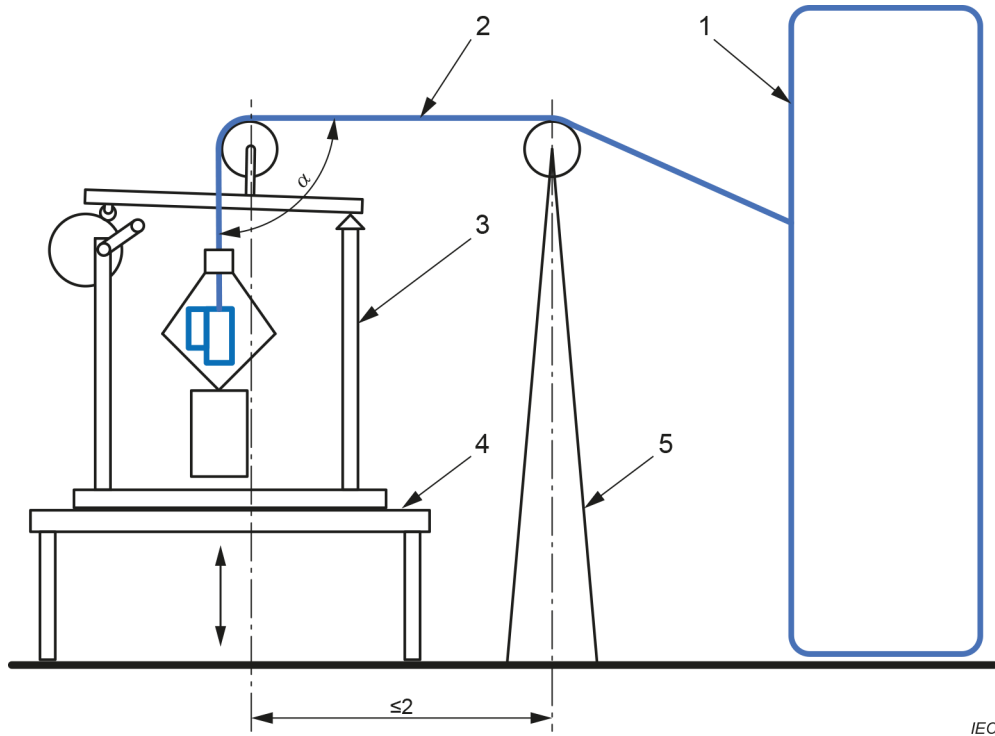

**Key**

- 1 DUT
- 2 side B cable assembly
- 3 test apparatus
- 4 table, height adjustable
- 5 cable support
- α 90° ± 10°

**Figure 111 – Test setup the side B cable assembly anchorage**

The vehicle connector, if any, of the side B cable assembly is fixed in the test apparatus (see Figure 110) so that the axis of the cable is vertical where it enters the vehicle connector.

If the free length of the side B cable assembly between the apparatus and the enclosure of the EV supply equipment is more than two meters, then the side B cable assembly shall be supported by appropriate means, see Figure 111. An adhesive strip shall be placed on the cable at the point where the side B cable assembly exits the DUT's enclosure or the strain relief means provided in the DUT. This adhesive strip will be used for the measurement of the longitudinal displacement after the force is applied by allowing for measurement of any displacement based on movement of the adhesive strip. Additionally, a mark is to be made on the adhesive strip and the enclosure or strain relief means, and the two marks are to be aligned in order to indicate any twisting or rotary movement of the cable after the torque is applied.

The side B cable assembly shall be subjected 100 times to a pull of the value specified in Table 114. Each pull shall be applied without jerks and with a duration of 1 s.

Immediately afterwards, the side B cable assembly shall be subjected to a torque of the value specified in Table 114 for 1 min.

After the tests, any displacement of the adhesive strip from the point where it enters the enclosure or strain relief means is to be measured. Additionally, any displacement between the mark made on the adhesive strip and the mark made on the enclosure or strain relief means is to be measured. These measured values are then compared to the maximum displacement values in Table 114.

**Table 114 – Pull force and torque test values for side B cable assembly anchorage**

Rated continuous current of the EV supply equipment at side B	Pulling force	Torque	Maximum displacement
A	N	Nm	mm
13 to 20	160	0,6	2,4
30 to 32	200	0,7	2,4
60 to 70	240	1,4	2,4
125	240	2,7	2,4
200	250	5,4	2,4
250	500	11,0	4,8
> 400	500	16,3	4,8

The test is passed if all the following conditions are met:

- the side B cable assembly shall not indicate damage when inspected by normal or corrected vision;
- the side B cable assembly shall not be displaced by more than the values indicated in Table 114.

#### **11.101 Cable breakaway**

The cable shall be constructed or connected to terminals within the enclosure in such a way that, if the cable anchorage fails, the conductors would break in the following sequence when strain is applied:

- the control pilot conductor/conductors;
- the current carrying conductors;
- the protective conductor.

Compliance is checked by inspection.

#### **11.102 Surface temperature of the side B cable assembly**

The side B cable assembly (including cable, vehicle connector and any additional handle or grip) shall be treated as a graspable part.

The surface temperature of the side B cable assembly (including the vehicle connector) shall be less than or equal to the temperature rating of the insulation used and, during normal operation of the EV supply equipment under the ambient temperature of 40 °C, the graspable part shall be ≤ 50 °C for metal parts and ≤ 60 °C for non-metal parts.

If the cable surface is intended to be considered as a touchable part, the cable shall be provided with a warning label or marking according to ISO 7010-W017:2011-05 (hot surface) or ISO 7010-W001:2011-05 (general warning) attached and be equipped with a handle or a grip (see Figure 112). In such case, the touchable part shall be ≤ 60 °C for metal parts and ≤ 85 °C for non-metal parts.

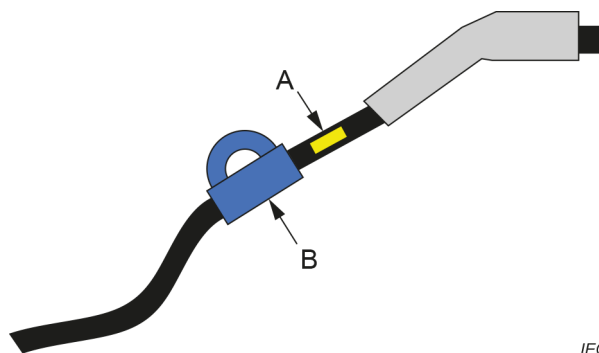

IEC

**Key**

- A warning label
- B handle or grip

**Figure 112 – Example of a side B cable assembly equipped with handle and a warning label attached to the cable**

NOTE In the following countries, the warning label is mandatory: JP, CA.

*Compliance is checked by the following test.*

*For a side B cable assembly equipped only with thermal sensing, the test shall be performed at an ambient temperature between 20 °C and 40 °C and the obtained results shall be corrected to an ambient temperature of 40 °C (if applicable).*

*For a side B cable assembly equipped with thermal transport device, the test shall be performed at an ambient temperature of (40 ± 5) °C. The results are corrected to an ambient temperature of 40 °C.*

*For an EV supply equipment that does not support the boost current, the following applies.*

- *Thermal stabilisation is considered to have occurred when three successive readings, taken at intervals of 10 min or more, indicate an increase of ≤ 2 K.*
- *The test current is the rated continuous current of the EV supply equipment at side B, according to EV supply equipment manufacturer’s data sheet, if not stated otherwise, and shall remain constant during the test.*

*For an EV supply equipment that supports the boost current, the following applies.*

- *Thermal stabilisation is considered to have occurred when the temperature reading reached the maximum value specified by the EV supply equipment manufacturer.*
- *The test current is initially the rated boost current of the EV supply equipment at side B, which will be reduced to the rated continuous current of the EV supply equipment at side B after transferring energy for a certain period of time during the test, all of which may be specified in the EV supply equipment manufacturer’s data sheet, if not stated otherwise.*

*The test procedure is as follows.*

- 1) *Connect the EV supply equipment to a test load with a dedicated EV simulator for the system under test. The setup of the test load for each system is shown in Table AA.10, Table BB.2, and Figure 132.*
- 2) *Start the measurement of the surface temperature of the side B cable assembly. The measurement points shall include two or more locations from each of the touchable and graspable part of the side B cable assembly, that is, four points or more in total.*

- 3) *Start energy transfer at the test current with the procedure specified by the EV supply equipment manufacturer. For an EV supply equipment supporting boost current, repeat the designated communication session cyclically until the thermal stabilization of the surface temperature of the side B cable assembly has been confirmed.*
- 4) *Confirm that the thermal stabilization has been reached for all the measurement points.*

*This test is passed if*

- *for non-metal parts: all the temperature measurements are  $\leq 60$  °C for the graspable part and  $\leq 85$  °C for the touchable part during the test, and*
- *for metal parts: all the temperature measurements are  $\leq 50$  °C for the graspable part and  $\leq 60$  °C for the touchable part during the test.*

## **12 EV supply equipment constructional requirements and tests**

IEC 61851-1:2017, Clause 12, is applicable, except as follows.

### **12.1 General**

*Addition:*

The EV supply equipment shall comply with the restrictions/limitations as specified in the data sheet of the side B cable assembly manufacturer.

*Compliance is checked by inspection.*

### **12.2 Characteristics of mechanical switching devices**

#### **12.2.5 Relays**

IEC 61851-1:2017, 12.2.5, is not applicable.

### **12.3 Clearances and creepage distances**

*Replacement of the 1<sup>st</sup> paragraph:*

The clearance and creepage distances in the DC EV supply equipment, installed as intended by the EV supply equipment manufacturer, shall be according to the requirements specified in IEC 62477-1.

*Addition:*

The side B of an EV supply equipment shall be designed according to a rated impulse voltage of  $\geq 2\,500$  V DC.

*Compliance is checked according to IEC 61851-1:2017, 12.7.*

### **12.4 IP degrees**

#### **12.4.1 Degrees of protection against solid foreign objects and water for the enclosures**

*Addition:*

For an EV supply equipment of stationary type, the test conditions shall be according to the installation conditions specified by the EV supply equipment manufacturer. These conditions shall be as indicated in the installation manual.

## 12.5 Insulation resistance

IEC 61851-1:2017, 12.5, is applicable, except as follows.

*Replacement of the last paragraph:*

The conditioning test for the insulation test and the touch current can be avoided if the conditioning for the test of IEC 61851-23:2023, 12.9, followed by test of IEC 61851-23:2023, 12.5, IEC 61851-23:2023, 12.6, and final test of IEC 61851-23:2023, 12.9, are conducted sequentially in that order.

*Addition:*

Insulation resistance does not include components bridging insulation according to 12.108 and IMD or earth leakage current monitoring device. These circuits shall be disconnected during the test.

## 12.6 Touch current

IEC 61851-1:2017, 12.6, is replaced with the following.

*Replacement:*

### 12.6.101 Touch current limit

The AC (RMS) and DC touch current shall be less than or equal to the values indicated in Table 115.

**Table 115 – Touch current limits**

Condition	AC (RMS)	DC
Normal operation	0,5 mA	2 mA
Fault condition according to IEC 60990:2016, 6.2.2	3,5 mA	10 mA

For class I EV supply equipment, if the test touch current is more than the limits of Table 115, 12.6.103 is applicable.

*Compliance is checked by the test in 12.6.102.*

### 12.6.102 Test

#### 12.6.102.1 Test configuration

*Test configurations for measurement of leakage current shall be according to IEC 60990:2016, 5.4.1. If the EV supply equipment is classified by the EV supply equipment manufacturer for use only on certain supply networks, the EV supply equipment shall be tested with each of those systems.*

#### 12.6.102.2 Application of measuring network

*The measuring network is defined in IEC 60990:2016, Figure 3, Figure 4 and Figure 5.*

*IEC 60990:2016, Figure 4, shall be applied for AC touch current measurement  $\leq 2$  mA RMS, and IEC 60990:2016, Figure 5, shall be applied for AC touch current measurement  $> 2$  mA RMS.*

*Any of IEC 60990:2016, Figure 3, Figure 4 or Figure 5, shall be used for DC touch current measurement.*

*Terminal A of the measuring network is connected to each conductive or unearthed accessible surface in turn. For each application of the terminal A electrode, the terminal B electrode is applied to earth, then to each of the other accessible parts in turn. All accessible conductive or unearthed surfaces are to be tested for touch currents.*

*For an accessible non-conductive part, the test is made to metal foil having dimensions of 100 mm by 200 mm in contact with the part.*

#### **12.6.102.3 Test condition**

*Circuitry which is connected through a fixed resistance or referenced to earth for monitoring purpose which is not continuously operated, and which does not contribute to a protective conductor current during normal operation of the side B circuit of EV supply equipment may be disconnected before this test.*

*The test shall be made with the EV supply equipment to a test load with a dedicated EV simulator for the system under test according to Figure 132 at rated boost power of the EV supply equipment at side B.*

*The touch current shall be measured in 1 h or less after the damp heat continuous test of IEC 60068-2-78, test Cab, at  $40\text{ °C} \pm 2\text{ °C}$  and 93 % relative humidity for 4 d, with the EV supply equipment connected to a supply network according to IEC 60990:2016, Clause 6. The present voltage at side A shall be the rated maximum voltage of the supply network.*

*Measurements shall be made with each of the applicable fault conditions according to IEC 60990:2016, 6.2.2.*

#### **12.6.102.4 Test measurements**

*The AC (RMS) value and the DC value of touch current shall be determined as indicated in IEC 60990:2016, Figure 3, Figure 4 or Figure 5.*

*The test is passed if the measured values are less than or equal to the corresponding touch-current limits specified in Table 115.*

#### **12.6.103 Protection measures for the test touch current more than 3,5 mA**

For the side A of a class I EV supply equipment under the fault condition of opened earthing conductor, if the test touch current under the fault condition of opened earthing conductor is  $> 3,5\text{ mA RMS}$ , one of the following requirements shall be met.

- a) The protective earthing conductor shall have a cross-sectional area of  $\geq 10\text{ mm}^2$  Cu or  $\geq 16\text{ mm}^2$  Al, through its total length.
- b) Where the protective earthing conductor has a cross-sectional area of  $< 10\text{ mm}^2$  Cu or  $< 16\text{ mm}^2$  Al, a second protective earthing conductor of more than or equal to the same cross-sectional area shall be provided up to a point where the protective earthing conductor has a cross-sectional area of  $\geq 10\text{ mm}^2$  Cu or  $\geq 16\text{ mm}^2$  Al.

NOTE This can require that the EV supply equipment has a separate terminal for a second protective earthing conductor.

- c) Automatic disconnection of the supply in case of loss of continuity of the protective earthing conductor from supply network.

A caution symbol shall be placed on the outside of the EV supply equipment, visible to the user. See 16.1 e).

The minimum size of the protective earthing conductor shall be indicated in the installation manual. Local safety regulations can apply.

*Compliance is checked by inspection.*

## **12.7 Dielectric withstand voltage**

### **12.7.2 Impulse dielectric withstand (1,2 µs/50 µs)**

*Replacement of the 2<sup>nd</sup> paragraph:*

The impulse voltage shall be applied to side A live parts and exposed conductive parts.

*Additional subclauses:*

#### **12.7.101 Suppression of transient overvoltage at side A (insulation coordination)**

When applying the test setup of IEC 61851-21-2:2018, Annex E, with an impulse voltage according to IEC 60664-1:2020, Table F.1, at side A, the EV supply equipment shall limit the present voltage at side B to:

- 2 500 V DC between DC+ and the protective conductor,
- 2 500 V DC between DC– and the protective conductor, and
- (present voltage at side B (before the impulse) plus 500 V DC) between DC+ and DC– .

*Compliance is checked by applying the test setup of IEC 61851-21-2:2018, Annex E, with a present voltage at side A according to IEC 60664-1:2020, Table F.1.*

*The test shall be performed with the test setup as described in IEC 61851-21-2:2018, Figure E.1, with the following modifications:*

- *without a DC power feed through filter (no.15);*
- *without a power load (no.16);*
- *with open lines at the supply/load port of termination (no.10).*

*For EV supply equipment designed to be connected to an AC supply network, the test shall be performed sequentially between L1/L2/L3/N and PE with a single positive pulse at the highest peak of the sine wave, and between L1/L2/L3/N and PE with a single negative pulse at the lowest peak of the sine wave.*

*For EV supply equipment designed to be connected to a DC supply network, the test shall be performed sequentially between L+/L- and PE with a single positive pulse and a single negative pulse.*

*The test shall be performed at*

- *rated maximum voltage of the EV supply equipment at side B, and*
- *rated minimum voltage of the EV supply equipment at side B.*

*For system A, this test shall be performed during insulation resistance check before energy transfer. A special test-mode with CVM can be used, if available.*

*For system B and system C, this test shall be performed in CVM.*

NOTE 1 The overvoltage reduction can be achieved by combination of one or more attenuation means according to IEC 60664-1:2020, 4.2.2.5.

NOTE 2 For specification of the overvoltage category (OVC) of side A of the EV supply equipment, see IEC 61851-1:2017, 12.3.

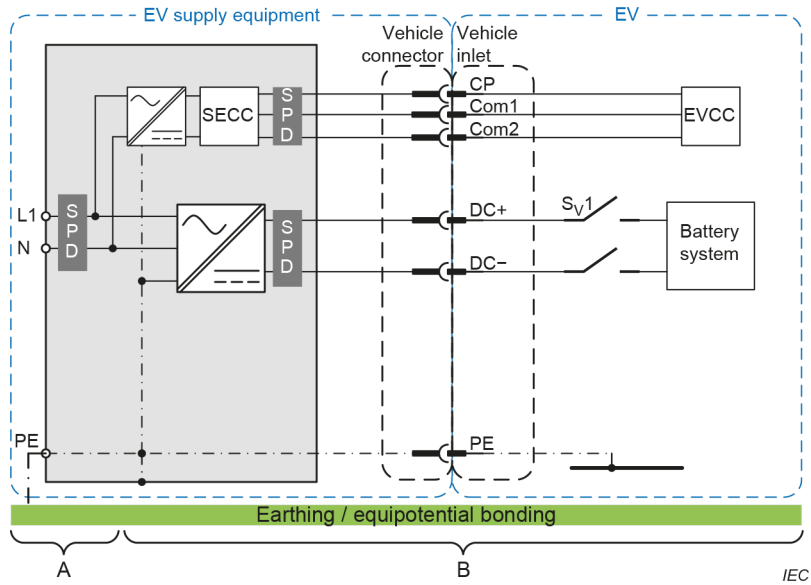

a) EV supply equipment

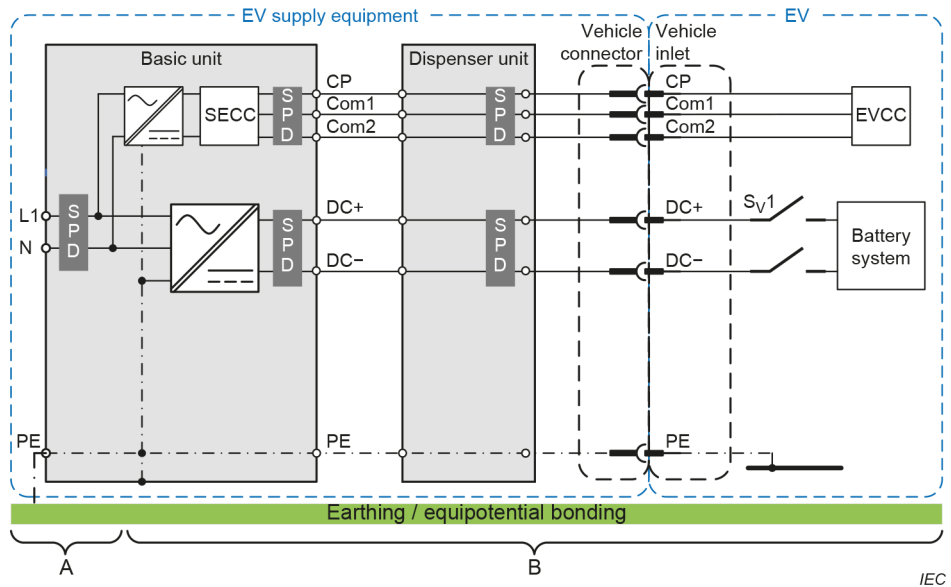

b) EV supply equipment with a basic unit and a dispenser unit

**Key**

L1, N	AC or DC supply network	CP	control pilot(s) and/or digital communication conductors
PE	protective conductor	SPD	surge protection device
DC+	positive terminal of side B	A	see 12.7.101
DC-	negative terminal of side B	B	see 12.7.102
Com1, Com2	digital communication conductors (if applicable)		

NOTE Examples: In case the EV supply equipment has long DC cables, or DC cables close to a lightning protection system.

**Figure 113 – Example setup of SPD for the protection of the EV supply equipment against transients**

### 12.7.102 Protection against transient overvoltages of atmospheric origin or due to switching

Any power or digital communication conductors connected to the EV supply equipment shall be protected against lightning or switching events by the use of appropriate means, such as:

- surge protective devices (SPDs) within the EV supply equipment;
- SPDs within side A of the EV supply equipment;
- environmentally protected installations of the EV supply equipment.

The EV supply equipment shall be classified with respect to the SPD function installed according to IEC 60364-5-53:2019, Clause 534. This information shall be provided in the installation manual.

The selection and erection of SPDs shall be done according to IEC 60364-5-53:2019, Clause 534.

SPDs shall be according to:

- IEC 61643-11 for AC, if any,
- IEC 61643-21 for digital communication conductors, if any, and

SPDs should be according to IEC 61643-41<sup>6</sup>, for DC, if any.

Surge protective components (for example, MOV, GDT, TVS) can be incorporated in the EV supply equipment for other reasons. If these components are used as part of an SPD, the SPD shall be tested according to the IEC 61643 series.

The EV supply equipment shall provide a protection level at the vehicle connector for system A, system B or system C with a rated maximum voltage of the EV supply equipment at side B  $\leq 1\,000$  V DC, for example, by using SPDs with a protection level of:

- 2 500 V DC between DC+ and protective conductor, and
- 2 500 V DC between DC– and protective conductor.

The installation manual of the EV supply equipment shall include the following information for the erection and energy coordination of the SPDs for protection against transient overvoltages at the vehicle connector:

- The installation including the EV supply equipment shall provide a protection level at the vehicle connector of 2 500 V between DC+/DC– and protective conductor, for example, by using SPDs.
- Either:
  - what types of SPDs are installed in the EV supply equipment, including the discharge current at which the protection level of 2 500 V DC between DC+/DC– and protective earthing conductor can be met, or
  - that no SPD is installed.
- IEC 60364-5-53 provides information for the energy coordination of the SPDs included in EV supply equipment with upstream SPDs already erected in the supply network.
- The IEC 62305 series provides information for protection against lightning. The test class and the surge/impulse current requirement ( $I_n$  and/or  $I_{imp}$ ) for these devices may be determined according to the IEC 60364-5-53.

---

<sup>6</sup> Under preparation. Stage at the time of publication: IEC CC 61643-41:2023.

- SPDs and other clamping devices limiting the voltage at the side B circuit, between live parts (DC+/DC–) and the protective conductor, shall have high impedance with a rated DC withstand voltage of  $\geq 1\,200$  V DC; for example, SPD-assemblies which include one or more "voltage switching type" SPD between side B live parts (DC+ and DC–) and the protective conductor can meet this requirement. A simultaneous transient overvoltage during a temporary overvoltage needs not to be considered, because this temporary overvoltage only occurs for a short period of time. See Figure 114.

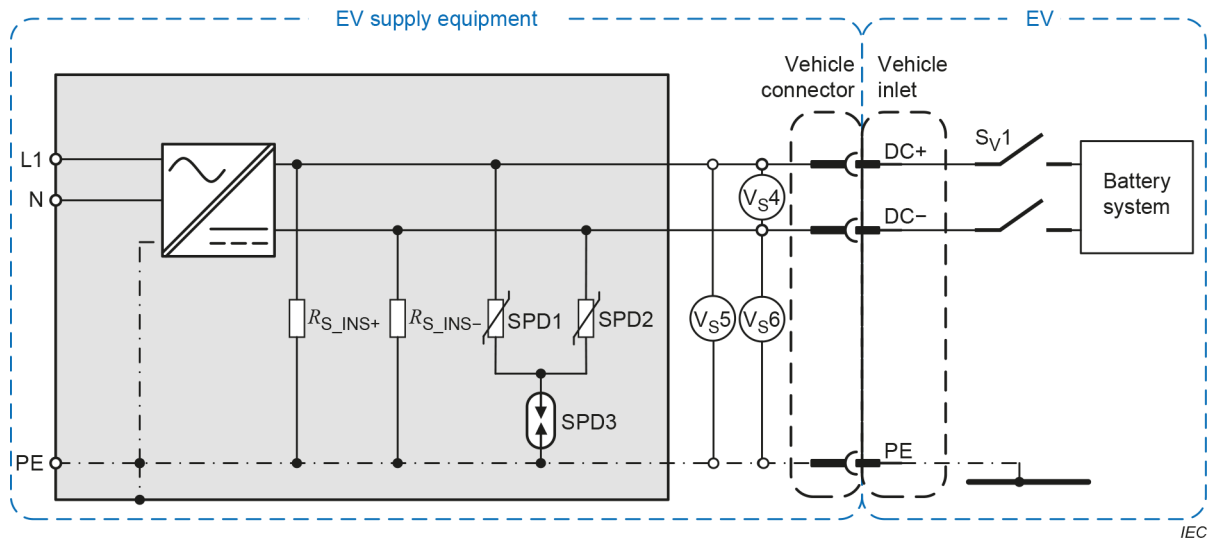

#### Key

L, N	AC or DC supply network	$V_{S4}$	maximum side B voltage between DC+ and DC– of 1 000 V DC
PE	protective conductor	$V_{S5}$	worst case: permanent unbalanced voltage between DC+ and PE $\leq 1\,000$ V DC
DC+	positive terminal of side B	$V_{S6}$	worst case: permanent unbalanced voltage between DC– and PE $\leq 1\,000$ V DC
DC–	negative terminal of side B	SDP1, SDP2	surge protection devices, for example, varistors
$R_{S\_INS+}$ , $R_{S\_INS-}$	worst case: internal insulation resistance $\geq 100$ k $\Omega$	SDP3	protective gap

**Figure 114 – Example of an SPD-assembly having one voltage switching type SPD between side B live conductors (DC+/DC–) and protective conductor**

- Suitable routing of the side B circuit minimizes induction loops and reduces the creation of surge voltages internally in side B. The loop area can be minimized by routing the live parts (DC+/DC–) of the side B circuit close to each other and close to the protective conductor, and by routing electrical and signal lines together. See IEC 62305-4.
- Shielding of internal lines, for example, using shielded cables or cable ducts, minimizes internally induced surges in case of long DC cables ( $> 10$  m) or in case DC cables running close to a lightning-protection-system (LPS) – shields need to be bonded at either end.
- A common earthing and/or bonding network minimize potential differences and may reduce the magnetic field, see IEC 62305-4.

## 12.8 Temperature rise

*Replacement:*

Low-voltage switchgear and controlgear assemblies shall comply with the temperature rise requirements in IEC 61439-7:2022.

Components shall comply with the temperature rise requirements of their appropriate standards.

## 12.9 Damp heat functional test

*Replacement:*

During the conditioning defined below, the EV supply equipment shall be de-energized. Following the conditioning and within 1 h, the EV supply equipment shall pass the compliance test in 6.3.1.105.

Conditioning:

- for indoor units, 6 cycles of 24 h each to a damp heat cycling test according to IEC 60068-2-30 (test Db) at  $(40 \pm 3)$  °C and relative humidity of 95 %;
- for outdoor units, 10 cycles of 24 h each to a damp heat cycling test according to IEC 60068-2-30 (test Db) at  $(40 \pm 3)$  °C and relative humidity of 95 %.

The application of the salt mist test of IEC 60068-2-11 is under consideration.

## 12.10 Minimum temperature functional test

*Replacement of the 2<sup>nd</sup> paragraph:*

The EV supply equipment is deemed to pass the test if, immediately after the preconditioning, it passes the test according to 6.3.1.105 while at the minimum operating temperature. The precision of the timing does not need to be verified.

## 12.11 Mechanical strength

*Replacement:*

For mode 4 EV supply equipment, the minimum degree of protection of the external enclosure against mechanical impact shall be IK08 according to IEC 62262.

The enclosure of EV supply equipment, when subjected to impact forces, shall not crack or break to the extent that any of the following occurs:

- uninsulated live parts are made accessible to the jointed test finger according to IEC 60529;
- the IP rating of the enclosure according to 12.4 is compromised;
- clearances and creepage distances are reduced to a value less than the minimum values according to 12.3;
- the equipment is damaged in any way that would prevent compliance with the requirements in this document.

Other requirements for strength of materials and parts are described in 12.107.2.

*Compliance is checked by the following test.*

*One sample of the EV supply equipment is subjected to this test. For wall or ground mounted equipment, the test is performed on all exposed enclosure faces when the equipment is positioned as intended after mounting. For portable and mobile EV supply equipment, the test shall be performed on all enclosure surfaces unless the EV supply equipment is designed such that specific orientations of the EV supply equipment are required for proper operation.*

*The EV supply equipment is placed on a concrete surface with the enclosure face under test in a horizontal position facing upwards. The impact is delivered by vertical hammer that is dropped and allowed to impact the enclosure surface. The EV supply equipment is repositioned for all enclosure faces to be tested. The test shall be performed on the EV supply equipment in the as-received condition and no pre-conditioning of the equipment is required. The EV supply equipment is not energized during this test.*

*The impact force is imparted through a vertical hammer in according to IEC 60068-2-75:2014, Figure A.3. The vertical hammer is constructed of steel with an overall mass of  $1,7 \text{ kg} \pm 0,2 \text{ kg}$ . The dimensions shown in IEC 60068-2-75:2014, Figure A.3, are an example of how to achieve the correct test object, but the overall length can be varied in order to achieve the correct overall mass.*

*The vertical hammer is allowed to fall freely from a height of 300 mm and impact the enclosure face under test. Secondary strikes, or rebounds, are to be avoided. Each enclosure face under test, including movable parts, shall be impacted three times, with each impact in a different location. Blows shall not be applied on components mounted on or in the surface of the enclosure, for example, socket outlets, cable assemblies according to IEC 62196-1, IEC 62196-3 and IEC 62196-3-1, push-buttons, and displays.*

*After each impact, the enclosure is observed to determine if any cracking or breaking occurred. Blemishes, scratches, scuffing, and the like are not considered. If there are any doubts that a crack or break in the enclosure is noncompliant, the applicable tests or evaluations shall be repeated to verify compliance.*

Portable and mobile EV supply equipment less than 18 kg shall comply with IEC 62368-1:2023, 4.4.3.3.

*Additional subclauses:*

#### **12.101 Side A current**

The present current at side A of the EV supply equipment shall not be more than the rated maximum current of the EV supply equipment at side A in FPT by more than 10 % under the most onerous energy transfer conditions.

*Compliance is checked by measuring the present current at side A of the EV supply equipment under the operating point (102.2.5) which produces the highest value of present current at side A:*

- when the EV supply equipment has more than one rated maximum voltage of the EV supply equipment at side A, the present current at side A in FPT is measured at each voltage rating;*
- when the EV supply equipment has one or more ranges of rated maximum voltage of the EV supply equipment at side A, the present current at side A in FPT is measured at the extremes of each rated voltage range.*

*Each measurement of the present current at side A shall be taken when the present current at side A has stabilized.*

## 12.102 Power supply cords

### 12.102.1 General

If a power supply cord is provided as an integral part of the EV supply equipment, the power supply cord shall be of the sheathed type and comply with the following:

- if rubber sheathed, be of synthetic rubber sheathed flexible cord according to IEC 60245-1:2003, designated 60245 IEC 53, IEC 57 or IEC 66;
- if PVC sheathed:
  - a) for equipment provided with a non-detachable power supply cord and having a mass  $\leq 3$  kg, be light PVC sheathed flexible cord according to IEC 60227-1:2007, designated 60227 IEC 52 or IEC 53;
  - b) for equipment provided with a non-detachable power supply cord and having a mass  $> 3$  kg, be ordinary PVC sheathed flexible power supply cord according to IEC 60227-1:2007, designated 60227 IEC 53;
  - c) for equipment provided with a detachable power supply cord, be light PVC sheathed flexible cord according to IEC 60227-1:2007, designated 60227 IEC 52 or IEC 53.

NOTE There is no limit on the mass of the equipment if the equipment is intended for use with a detachable power supply cord.

For plug and cable EV supply equipment, a protective conductor shall be included in the power supply cord.

*Compliance is checked by inspection.*

### 12.102.2 Cross-sectional area

The power supply cords shall have conductors with cross-sectional areas more than or equal to those specified in Table 116.

**Table 116 – Sizes of conductors of power supply cord**

Rated maximum current of the EV supply equipment at side A <sup>a</sup>	Minimum conductor sizes	
	Cross-sectional area mm <sup>2</sup>	AWG or kcmil [cross-sectional area in mm <sup>2</sup> ] <sup>e</sup>
A ≤		
3	0,5 <sup>b</sup>	20 [0,5]
6	0,75	18 [0,8]
10	1,00 (0,75) <sup>c</sup>	16 [1,3]
16	1,50 (1,0) <sup>d</sup>	14 [2]
25	2,5	12 [3]
32	4	10 [5]
40	6	8 [8]
63	10	6 [13]
80	16	4 [21]
100	25	2 [33]
125	35	1 [42]
160	50	0 [53]
190	70	000 [85]
230	95	0000 [107]

Rated maximum current of the EV supply equipment at side A <sup>a</sup>	Minimum conductor sizes	
	Cross-sectional area mm <sup>2</sup>	AWG or kcmil [cross-sectional area in mm <sup>2</sup> ] <sup>e</sup>
A ≤		
260	120	250 [126]
300	150	300 [152]
340	185	400 [202]
400	240	500 [253]
460	300	600 [304]
NOTE 1 IEC 60320-1 specifies acceptable combinations of household appliance couplers and flexible cords, including those covered by footnotes <sup>b</sup> , <sup>c</sup> and <sup>d</sup> . However, several countries have indicated that they do not accept all the values listed in this table, particularly those covered by footnotes <sup>b</sup> , <sup>c</sup> and <sup>d</sup> .		
NOTE 2 For higher currents, see the IEC 60364 series.		
<sup>a</sup> The rated maximum current of the EV supply equipment at side A includes currents that can be drawn from a socket outlet providing mains power for other equipment. <sup>b</sup> For a rated maximum current of the EV supply equipment at side A ≤ 3 A, a nominal cross-sectional area of 0,5 mm <sup>2</sup> may be used in some countries, provided that the length of the cord is ≤ 2 m. <sup>c</sup> The value in parentheses applies to detachable power supply cords fitted with the connectors rated 10 A according to IEC 60320-1 (types C13, C15, C15A and C17) provided that the length of the cord is ≤ 2 m. <sup>d</sup> The value in parentheses applies to detachable power supply cords fitted with the connectors rated 16 A in accordance with IEC 60320-1 (types C19, C21 and C23) provided that the length of the cord is < 2 m. <sup>e</sup> AWG and kcmil sizes are provided for information only. The associated cross-sectional areas, in square brackets, have been rounded to show significant figures only. AWG refers to the American Wire Gage and the term "cmil" refers to circular mils where one circular mil is equal to the area of a circle having a diameter of one mil (one thousandth of an inch or 0,025 4 mm). These terms are commonly used to designate wire sizes in North America.		

*Compliance is checked by inspection.*

### 12.102.3 Cord anchorages and strain relief for non-detachable power supply cords

#### 12.102.3.1 Cord strain relief

##### 12.102.3.1.1 General

Protective measures against strain being transmitted to the EV supply equipment terminations of the conductors of the power supply cord are specified below.

A knot in the power supply cord or cable shall not be used as a strain relief mechanism.

A screw that bears directly on the cord or cable shall not be used as a strain relief mechanism unless the cord anchorage, including the screw, is made of insulating material and the screw is of comparable size to the diameter of the cord being clamped.

When a pull force and a torque are applied to a non-detachable power supply cord or cable, a basic safeguard shall minimize strain from being transmitted to the cord or cable terminations.

*Compliance is checked by the following test.*

*The pull force applied to the cord or cable is specified in Table 117. The force is applied in the most unfavourable direction for 1 s and repeated 25 times.*

**Table 117 – Cord strain relief pull force**

<b>Mass of the equipment</b> kg	<b>Force</b> N
≤ 1	30
> 1 and ≤ 4	60
> 4	100

*Immediately after the 25<sup>th</sup> pull force application, a torque of 0,25 Nm is applied for 1 min to the cord or cable. The torque is applied as close as practicable to the strain relief mechanism and is repeated in the opposite direction.*

*There shall be no damage to the cord or conductors and the displacement of the conductors shall be ≤ 2 mm. Stretching of the cord outer jacket without displacement of the conductors is not considered displacement.*

**12.102.3.1.2 Strain relief mechanism failure**

In addition to the cord strain relief means provided for the non-detachable power supply cord, a supplementary protective measure shall be provided to ensure that strain on the power supply cord conductors at the terminations within the EV supply equipment conductors will be such that the protective conductor termination is the last to take the strain.

*Compliance is checked by inspection and, if necessary, by defeating the basic protective measure and inspecting the conductor slack while applying the force in Table 117.*

**12.102.3.1.3 Cord sheath or jacket position**

The cord or cable sheath or jacket shall extend from the basic safeguard (strain relief mechanism) into the equipment more than or equal to one-half the diameter of the cord or cable.

*Compliance is checked by inspection.*

**12.102.3.1.4 Strain relief and cord anchorage material**

The cord anchorage shall either be made of insulating material or have a lining of insulating material complying with the requirements for basic insulation. Where the cord anchorage is a bushing that includes the electrical connection to the screen of a screened power cord, this requirement shall not apply.

If the basic protective means (strain relief mechanism) is made of polymeric material or if the basic protective means is mounted in an enclosure consisting of polymeric material, the basic protective means shall retain its structural properties following the mould stress relief according to 12.103.

*Compliance is checked by inspection and by applying the force and torque tests of 12.102.3.1 after the basic protective means has returned to room temperature following the stress relief test of 12.103.*

**12.103 Stress relief test**

Non-metallic materials that are used for enclosures, or other safety critical parts, shall not deteriorate, shrink, warp, melt, or deform such that the live parts become accessible, the IP rating is compromised, or the functionality of the part no longer meets the safety critical function for which it was intended.

*Compliance is checked by the following test.*

*One sample consisting of the complete equipment, or of the complete enclosure together with any supporting framework, is placed in a circulating air oven at a temperature 10 K more than the maximum temperature observed on the sample during the heating test of 12.107.2.2.1, but  $\geq 70$  °C, for a period of 7 h, then cooled to room temperature. Once the material has returned to room temperature, it is observed for any indication of deterioration, deformation, shrinkage, warping, or melting. Other tests may need to be repeated after this conditioning as indicated in individual test methods.*

For large EV supply equipment where it is impractical to condition a complete enclosure, a portion of the enclosure representative of the complete assembly with regard to thickness and shape, including any mechanical support members, may be used.

NOTE Relative air humidity need not be maintained at a specific value during this test.

## **12.104 Abnormal operation and simulated fault condition tests**

### **12.104.1 General**

Protection against the risk of thermal, electric shock and energy hazards in the case of an abnormal operating or simulated fault condition of the EV supply equipment shall be evaluated by tests defined in 12.104. Testing may be performed on sub-assemblies while positioned and operated under end use conditions.

Simulated abnormal operating and fault conditions shall be applied one at a time. Faults that are a direct consequence of a simulated fault or abnormal operating condition are considered to be a part of that simulated fault or abnormal operating condition.

Cheesecloth and/or surgical cotton shall be used as indicators for risk of fire. These indicators shall be placed at all openings on the outside of the enclosure in a manner which will not significantly affect cooling.

Where the installation manual requires external means of protection against faults, these specific means shall be provided for the test.

The voltages of accessible SELV circuits as well as accessible earthed and unearthed conductive parts shall be monitored.

The test shall be performed until terminated by activation of a protective device or mechanism (internal or external), a component failure occurs that interrupts the fault condition, temperatures stabilize, or a risk of fire and/or electric shock hazard occurs.

### **12.104.2 Pass criteria**

As a result of testing from 12.104.3 to 12.104.6, the EV supply equipment shall comply with the following:

- there shall be no emission of flame, burning particles or molten metal;
- the cheesecloth or surgical cotton indicator shall not have ignited;
- the earth connection, if any, and protective equipotential bonding shall not have opened;
- doors and covers shall remain in place;
- during and after the test, accessible SELV circuits and accessible conductive parts shall not exhibit voltages more than the touch voltages specified in 8.102.4;
- dielectric withstand voltage test specified in IEC 61851-1:2017, 12.7;
- devices/components used for the mounting of live parts shall not break away from their initial position;

- no conductor shall be pulled out of its terminal conductor.

The EV supply equipment is not required to be operational after testing and it is possible that the enclosure can become deformed. Overcurrent protection integral to the EV supply equipment, or specified by the installation manual to be used with the equipment, is allowed to open.

### **12.104.3 Breakdown of components test**

#### **12.104.3.1 Load conditions**

*The breakdown of a component, identified by circuit analysis, shall be tested with the EV supply equipment connected to a test load with a dedicated EV simulator for the system under test at the operating point that creates the most severe condition.*

*Testing may be conducted using the sub-assembly in which the identified component is located. In this case, the sub-assembly shall be loaded to simulate normal operating conditions.*

#### **12.104.3.2 Application of short-circuit or open circuit**

*The short-circuit shall be applied with test leads of a cross section appropriate for the current that normally flows through the component, but  $\geq 2,5 \text{ mm}^2$ . The length of the loop shall be as short as practical to perform the test. Short-circuits and open circuits are applied using an appropriate switching device.*

*Each identified component shall be subjected to only one simulation of breakdown unless both open circuit and short-circuit failure modes are likely in that component.*

#### **12.104.3.3 Test sequence**

*For the breakdown of components test, identified components shall be short-circuited or open circuited, whichever creates the worst hazard, one at a time.*

*Compliance is checked by the application of the pass criteria in 12.104.2. In addition, during and after the application of the short-circuit or open circuit, any flame inside the equipment shall extinguish in 10 s or less and no surrounding parts shall have ignited.*

#### **12.104.4 Loss of AC supply phase test**

*A multi-phase side A EV supply equipment shall be operated with each phase (including neutral, if used) disconnected in turn at side A of the EV supply equipment. The test shall be performed by disconnecting one phase with the equipment connected to a test load with a dedicated EV simulator for the system under test operating at rated maximum power of the EV supply equipment at side B. The test is repeated by initially energizing the EV supply equipment with one lead disconnected.*

*The test shall continue until terminated by a protective mechanism, a component failure occurs, or the temperature stabilizes.*

*Compliance is checked by the application of the pass criteria in 12.104.2.*

#### **12.104.5 Inoperative blower/fan motor test**

*EV supply equipment with forced ventilation shall be connected to a test load with a dedicated EV simulator for the system under test while operating at rated boost current of the EV supply equipment at side B with the fan or blower motor or motors made inoperative either individually or in combination from a single fault. The fan or blower motor shall be made inoperative by either physically preventing rotation or by disconnecting its power source.*

*Compliance is checked by the application of the pass criteria in 12.104.2.*

#### **12.104.6 Clogged filter test**

*EV supply equipment with filtered ventilation openings shall be connected to a test load with a dedicated EV simulator for the system under test while operating at rated boost current of the EV supply equipment at side B with the openings blocked to represent clogged filters. The test shall be performed initially with 50 % of the ventilation openings surface blocked. The test shall be repeated under a full blocked condition.*

*Compliance is checked by the application of the pass criteria in 12.104.2.*

### **12.105 Protection against electrically caused fire**

#### **12.105.1 General**

The protective measure to reduce the risk of the spread of fire under normal operating conditions and single fault conditions to the environment from within is two-fold:

- implementation of a fire enclosure;
- selection of internal combustible parts with a low flammability classification.

NOTE Normally, abnormal operating and fault condition testing (for example, open circuit and short-circuit of electronic components) would be required to demonstrate the potential risk of fire coverage. However, this protective measure is designed to facilitate the use of low flammability classification internal materials and a fire enclosure (external or internal or a combination of both) to provide containment of fire originating from within.

#### **12.105.2 Fire enclosure**

Fire enclosures are used to reduce the risk of the spread of fire to the environment from within, independent of the location where they are installed. An overall fire enclosure shall be provided for the EV supply equipment unless internal fire enclosure(s) are provided.

The fire enclosure shall be designed according to IEC 62477-1:2022, 4.6.3.

Provision of internal fire enclosure(s) as the protective measure against the spread of electrically-caused fire leads to consideration of any external combustible parts, for example, decorative in function, located outside of the internal fire enclosure and not required as part of the protective measure. These external parts are not required to meet the 5 VB flammability class requirement and need only have a HB minimum classification.

Internal fire enclosure construction and internal combustible material considerations are the same as described.

Combustible materials located within the fire enclosure shall comply with IEC 62477-1:2022, 4.6.2.2.

*Compliance is checked by inspection and tests according to IEC 62477-1:2022, 4.6.2.2.*

### **12.106 Protection against chemical hazards**

#### **12.106.1 Type of coolant**

The liquid coolant utilized shall be non-hazardous to the environment according to the Globally harmonized system for the classification and labelling of chemicals. The biodegradability of the liquid coolant shall be  $\geq 60$  % tested according to OECD 301 B and stated into the data sheet.

NOTE Local regulations can require other compliances.

Warnings shall be provided in the installation manual or data sheet indicating that leaking or material degradation might occur if a coolant other than that specified by the EV supply equipment manufacturer is used.

*Compliance is checked by inspection.*

### **12.106.2 Flammability**

The liquid coolant shall not lead to a fire hazard if leaked onto exposed electrical parts. The minimum flashpoint of the liquid coolant shall be 135 °C.

*Compliance is checked by inspection of the material safety data sheets or by the test according to ISO 2719.*

### **12.106.3 Material compatibility**

All liquid coolant confining parts of the liquid handling system shall be resistant to the action of the liquid coolant and shall not degrade over time due to the exposure to heat. Non-metallic parts shall be able to maintain their physical properties after being exposed to the liquid coolant and air over aging as follows.

*Compliance is checked by the following tests.*

#### **a) Air oven aging plastic parts and gaskets**

*Six specimens are aged in an air circulating oven at 121 °C for 7 days and shall maintain the physical properties of tensile strength and elongation. The tensile strength and ultimate elongation shall be  $\geq 60\%$  of the tensile strength and ultimate elongation of the as-received sample. The test method of IEC 60811-501 shall be followed.*

#### **b) Liquid coolant exposure**

*Other specimens are to be immersed in the liquid coolant at  $80\text{ °C} \pm 2,0\text{ °C}$  for  $70\text{ h} \pm 30\text{ min}$ .*

*Six samples of each material, 25,4 mm wide and 203 mm long and not thicker than the thinnest part in the application, are required for this test. Three are tested as-received and three are tested following immersion.*

*The tensile strength and ultimate elongation shall be  $\geq 60\%$  of the tensile strength and ultimate elongation of the as-received samples.*

#### **c) Creep resistance test**

*Two samples of each non-metallic part of the liquid coolant confining system shall be conditioned for 14 days at a temperature of 87 °C and placed in a full draft air-circulating oven. Following the conditioning, the parts shall show no sign of deterioration such as cracking and embrittlement.*

## **12.107 Enclosures**

### **12.107.1 General**

Enclosures shall be designed according to IEC 62477-1:2022, 4.12, except the requirements for degrees of protection in 12.4 and the impact test in 12.11 in this document applies.

*Compliance is checked by inspection and tests according to 12.4, 12.11 and IEC 62477 1:2022, 4.12, where applicable.*

NOTE In the following countries, national regulations provide requirements on the enclosure of EV supply equipment: US, JP.

## **12.107.2 Strength of materials and parts**

### **12.107.2.1 General**

Strength of materials and parts of EV supply equipment shall be according to IEC 61439-1:2020, 10.2, except for the impact test in 12.11 of this document.

The EV supply equipment shall be constructed of materials capable of withstanding the mechanical, electrical, thermal and environmental stresses that are likely to be encountered in anticipated service conditions.

### **12.107.2.2 Properties of insulating materials**

#### **12.107.2.2.1 Thermal stability**

For enclosures or parts of enclosures made of insulating materials, thermal stability shall be verified by the dry heat test.

*Compliance is checked by inspection and test in accordance with IEC 61439-1:2020, 10.2.3.1.*

#### **12.107.2.2.2 Resistance of insulating materials to heat and fire**

Resistance of insulating materials to heat and fire shall be according to IEC 61439-1:2020, 8.1.3.2.

*Compliance is checked by inspection of EV supply equipment manufacturer's test data or test.*

## **12.107.3 Enclosure integrity tests**

The enclosure integrity tests shall be according to IEC 62477-1:2022, 5.2.2.4.

NOTE The enclosure integrity tests specified in IEC 62477-1:2022 include the following tests: deflection, steady force, impact, drop, stress relief, stability, wall or ceiling mounted equipment, handles and manual controls securement test.

## **12.108 Components bridging insulation**

### **12.108.1 General**

Components bridging insulation shall comply with the requirements of the level of insulation, for example, basic, reinforced or double, they are bridging.

Components bridging insulation shall meet the requirements of IEC 62368-1:2023, 5.5, and be subjected to compliance testing as specified in that clause.

SPDs and other clamping devices limiting the voltage at the side B circuit, between live parts (DC+/DC-) and the protective conductor, shall have a rated DC withstand voltage of  $\geq 1\,200$  V DC.

EV manufacturers should consider that EV supply equipment designed according to IEC 61851-23:2014 can be equipped with SPDs with a lower DC withstand voltage.

NOTE 1 If clamping devices are used in EV, the EV manufacturer is advised to consider the requirement in 6.3.1.112.2.

NOTE 2 Due to the requirements for a double or reinforced insulation for working voltages  $> 550$  V DC (see 8.105.5) in case of a single earth fault, temporary overvoltages  $> 1\,200$  V DC between side B live parts (DC+/DC-) and the protective conductor do not occur.

*Compliance is checked by design review.*

### 12.108.2 Capacitors

Capacitors bridging insulation shall comply with IEC 60384-14.

*Compliance is checked by inspection.*

### 12.109 Isolating transformers

Isolating transformers, excluding safety isolating transformers used for auxiliary circuits, shall comply with the requirements of IEC 62368-1:2023, G.5.3, or both IEC 61558-1 and IEC 61558-2-4.

*Compliance is checked by inspection.*

## 13 Overload and short-circuit protection

IEC 61851-1:2017, Clause 13, is applicable, except as follows.

### 13.1 General

*Replacement:*

Where side B circuits can be used simultaneously and are intended to be supplied from the same side A, they shall have individual protection incorporated in the EV supply equipment.

If the EV supply equipment presents more than one side B circuits, then such side B circuits may have common overload protection means and may have common short-circuit protection means, if those protection means provide the required protection for each of the side B circuits (for example, the common protection device shall have a rating no higher than the lowest rating of the side B circuits).

NOTE 1 Such a configuration might have an impact on the availability of the EV supply equipment, which could be resolved by adequate load management (for example, load sharing).

If the EV supply equipment presents more than one side B circuit that cannot be used simultaneously, then such side B circuits can have common protection means.

NOTE 2 In the following countries, the methods of protection against overcurrent and overvoltage are in accordance with national codes: US, JP, CA.

NOTE 3 In the following countries, the branch circuit overcurrent protection is based upon 125 % of the rated maximum current of the EV supply equipment at side A: US, CA.

NOTE 4 In the following countries, FPT is considered a continuous load and is limited to 80 % of the branch circuit fuse or circuit breaker rating by national rules: US, CA.

NOTE 5 Protection devices can be provided inside the EV supply equipment, in the fixed installation or in both places.

NOTE 6 In the following countries, the protective conductor at side A complies with the test requirement in national standard: JP.

### 13.2 Overload protection of the cable assembly

IEC 61851-1:2017, 13.2, is not applicable.

### 13.3 Short-circuit protection of the charging cable

IEC 61851-1:2017, 13.3, is not applicable.

*Additional subclause:*

### **13.101 Short-circuit protection of the DC connection during energy transfer**

The EV supply equipment shall fulfil all the requirements a) to c) below, for a short-circuit current supplied by the EV supply equipment due to any of the following fault conditions:

- fault condition 1: a short-circuit between side B live parts (DC+ and DC–);
  - fault condition 2: a failure in the PEC, for example, a permanently fully conductive switching element in a buck converter.
- a) Limit the peak current, including transient effects, to:
- for system A:
    - $\leq 10$  kA at side B live parts (DC+ and DC–) of the vehicle connector for a present voltage at side B  $\leq 500$  V DC;
    - $[10 \text{ kA} \times (\text{present voltage at side B between DC+ and DC–} / 500 \text{ V DC})]$  (or less) at side B live parts (DC+ and DC–) of the vehicle connector for a present voltage at side B between DC+ and DC–  $> 500$  V DC;
  - for system B and system C:
    - $\leq 10$  kA at side B live parts (DC+ and DC–) of the vehicle connector.

NOTE 1 The short-circuit peak current value for the vehicle connector and vehicle inlet specified in IEC 62196-3 is under consideration.

- b) Limit the  $I^2t$  value to:
- $\leq 400\,000$  A<sup>2</sup>s at side B live parts (DC+ and DC–) of the vehicle connector for system A;
  - $\leq 500\,000$  A<sup>2</sup>s at side B live parts (DC+ and DC–) of the vehicle connector for system B;
  - $\leq 1\,000\,000$  A<sup>2</sup>s at side B live parts (DC+ and DC–) of the vehicle connector for system C.
- c) Trigger an emergency shutdown in 1 s or less after the start of the short-circuit condition as specified in the respective test.

If the short-circuit current supplied by the EV supply equipment is not sufficient to trip a fuse, if any, in the required time or less to limit the  $I^2t$  value, the EV supply equipment shall provide an alternative means to interrupt the short-circuit current.

NOTE 2 The current peak is a result of the discharge of the capacitance of the EV supply equipment. The capacitive discharge is a transient phenomenon in the range of milliseconds.

NOTE 3 Requirements for short-circuit check before energy transfer are given in 6.3.1.109.

*For system A, the compliance for a) to b) is demonstrated by design review with inspection and circuit analysis. Compliance for c) is checked by AA.3.8.3.*

*For system B, the compliance for a) to b) is demonstrated by design review with inspection and circuit analysis. Compliance for c) is checked by BB.5.8.*

*For system C, for fault condition 1, the compliance with requirements a) to c) is tested according to CC.7.6.16. For system C for fault condition 2, the compliance with requirements a) to c) is demonstrated through design review.*

For a short-circuit current supplied by the EV, the requirements in d) or e) shall be fulfilled.

- d) At the vehicle connector, the EV supply equipment shall have a short-circuit current withstand rating ( $I^2t$ ) and shall withstand a peak current according to the values as specified in ISO 17409:2020 for the different systems. The minimum cross-sectional area of the line conductors shall be calculated according to IEC 60364-4-43:2008, Formula (3).

NOTE 4 Short-circuit current withstand rating ( $I^2t$ ) for system B is not specified in ISO 17409:2015<sup>7</sup>, but it is specified as 5 000 000 A<sup>2</sup>s in CN standards.

NOTE 5 For the limits of  $I^2t$  according to ISO 17409:2015, see the warning in ISO 17409:2020, 7.2.4.2. The  $I^2t$  requirement for system C was 12 000 000 A<sup>2</sup>s in ISO 17409:2015.

- e) An overcurrent protection device shall be provided in side B of the EV supply equipment. The overcurrent protection device shall withstand a peak current according to the values as specified in ISO 17409:2020 for the different systems. The section of side B which is protected by this protection device shall be designed according to the characteristics of this overcurrent protection device. The section of side B which is not protected by this overcurrent protection device shall comply with requirement d).

*Compliance for requirements d) and e) is checked by inspection.*

## 14 Automatic reclosing of protective devices

IEC 61851-1:2017, Clause 14, is not applicable.

## 15 Emergency switching or disconnect (optional)

IEC 61851-1:2017, Clause 15, is applicable.

## 16 Marking and instructions

IEC 61851-1:2017, Clause 16, is applicable, except as follows.

### 16.1 Installation manual of EV charging stations

*Addition:*

For system B, 16.1 is under consideration.

#### a) Coolant

For system A and system C:

- if coolant is used, for example, for thermal management system, the installation manual of the EV supply equipment shall include information about the coolant properties according to 12.106;
- a standard sign "Refer to instruction manual" according to ISO 7010-M002:2011-05 shall be visibly attached to the thermal exchange;
- the name of the coolant shall be visible attached at the enclosure of the cooling unit.

#### b) RCD

For EV supply equipment intended for fixed installation, the installation manual shall include information about the protective measure to be provided by the installation. If, under normal and fault conditions, any resulting DC component of the current in the protective conductor may be > 6 mA DC, a caution notice and the symbol ISO 7000-0434B:2004-01 (see Figure 115) shall be provided in the installation manual, and the symbol shall be placed on the product. The caution notice shall be the following or equivalent (see also IEC 62477-1:2022, 6.3.9.5 and 4.4.8):

"CAUTION: This product can cause a DC current in the protective conductor. Where a residual current-operated protective device (RCD) is used for protection against electrical shock, only an RCD of type B is allowed on the supply side of this product."

---

<sup>7</sup> This publication has been withdrawn.



NOTE Denotes: Caution, refer to documentation.

**Figure 115 – Symbol ISO 7000-0434B:2004-01**

c) Maintenance program

The EV supply equipment manufacturer shall prescribe a preventative maintenance program, for example, for the replacement of the side B cable assembly following a predetermined period of time in service and/or number of coupling sessions.

d) Power distribution system

The installation manual shall include information about the classification described in 5.101.5.

e) Touch current

For an EV supply equipment that, under a fault condition of loss of electrical continuity of the earthing conductor, has a test touch current of  $> 3,5$  mA AC RMS, the installation manual shall include the following information.

- A caution notice and the symbol ISO 7000-0434B:2004-01, ISO 7010-W012:2011-05, or IEC 60417-6042:2010-11 (see Figure 115). The caution notice shall be the following or equivalent:

"CAUTION: A touch current  $> 3,5$  mA AC RMS is possible in case of a fault condition of loss of electrical continuity of the earthing conductor."

- The minimum size of the protective earthing conductor shall comply with the local safety regulations.

f) Connection of the protective conductor to a protective earthing conductor or earth

A caution notice shall be provided in the installation manual if the EV supply equipment, when installed, is allowed to be connected to a supply network that does not provide a protective conductor or a protective conductor that is not earthed. In this case, the EV supply equipment manufacturer shall provide a label according to item k) in 16.3, to mark the EV supply equipment during the installation.

Additional requirements for the contents of the installation manual in 9.7, 12.4.1, 12.7.102, 12.104.2, 12.106.1 and 101.1.1 shall be included.

*Compliance is checked by inspection.*

## 16.2 User manual for EV supply equipment

*Addition:*

The user manual shall provide information on which type of personnel is allowed to operate the EV supply equipment according to the supply network it is connected to when installed. The information shall be the following or equivalent:

- "The EV supply equipment is allowed to be operated by an ordinary person if the EV supply equipment, when installed, is connected to a supply network that provides a protective earthing conductor."
- "The EV supply equipment is only allowed to be operated by skilled personnel or instructed personnel if the EV supply equipment, when installed, is connected to a supply network that does not provide a protective conductor or a protective conductor that is not earthed."

Additional requirements for the contents of the user manual in 101.1.1 and FF.4.2 shall be included.

*Compliance is checked by inspection.*

### 16.3 Marking of EV supply equipment

*Addition:*

- k) "Only to be used by skilled or instructed personnel", or equivalent, if the EV supply equipment was installed to a supply network that does not provide a protective conductor or a protective conductor that is not earthed.

NOTE 2 EN 17186 provides labelling requirements depending on operating ranges and systems.

*Compliance is checked by inspection.*

### 16.4 Marking of charging cable assemblies case B

IEC 61851-1:2017, 16.4, is not applicable.

*Additional clauses:*

## 101 Specific requirements for EV supply equipment

### 101.1 Specific requirements for separated EV supply equipment

#### 101.1.1 Operating ranges for voltage, current, and power at side B

The EV supply equipment manufacturer shall specify the operating range using the following parameters, and indicate them in the user manual and the installation manual:

- rated voltage operating range at side B ( $V_{\min}$ ,  $V_{\max}$ );
- rated continuous current operating range at side B ( $I_{\min}$ ,  $I_{\text{cont}}$ );
- rated boost current operating range at side B ( $I_{\min}$ ,  $I_{\text{boost}}$ );
- rated continuous power operating range at side B ( $P_{\min}$ ,  $P_{\text{cont}}$ );
- rated boost power operating range at side B ( $P_{\min}$ ,  $P_{\text{boost}}$ );
- ambient operating temperature range;
- maximum operating altitude above sea level.

NOTE 1 IEC 61851-24 specifies which of these parameters need to be communicated to the EV using digital communication, and how this is accomplished.

The ambient operating temperature range shall at least cover the range from  $-5\text{ °C}$  to  $+40\text{ °C}$ .

NOTE 2 Subclause 12.10 specifies a minimum operating temperature of  $-25\text{ °C} \pm 3\text{ K}$  for outdoor use.

The maximum operating altitude shall be  $\geq 2\ 000\text{ m}$  above sea level.

NOTE 3 In the following countries, the maximum operating altitude can be  $\geq 1\ 000\text{ m}$  above sea level for system A EV supply equipment: JP.

The EV supply equipment manufacturer may specify one or more of the following additional operating ranges:

- ambient operating temperature range wider than the one referred to above;
- maximum operating altitude above sea level more than the one referred to above.

In such a case, the other parameter ranges applicable for those/this additional operating range(s) may deviate from the ones referred to above, for example:

- a rated voltage operating range at side B smaller than the one referred to above, and/or
- a rated continuous current operating range at side B smaller than the one referred to above, and/or
- a rated continuous power operating range at side B less than the one referred to above.

The EV supply equipment shall be able to provide energy transfer as specified in 101.1.2 between each operating range.

The present power at side B shall be less than or equal to the rated boost power of the EV supply equipment at side B, even if the target power of the EV is more than the rated boost power of the EV supply equipment at side B.

The EV supply equipment may also be able to operate at a value less than the lower limit of a specified operating range, that is, provide a present current at side B  $< I_{\min}$  or a present voltage at side B  $< V_{\min}$ , without the need to fulfil all the requirements given in 101.1.2.

### **101.1.2 Voltage and current tolerance at side B**

#### **101.1.2.1 Side B current regulation in CCM**

Requirements for side B current regulation in CCM are specified in AA.3.10, BB.4.1 and CC.6.2.

The EV supply equipment shall limit the present voltage at side B to the target voltage of the EV with a maximum allowable deviation defined in 101.1.2.2.

*Compliance for system A and system B is checked by the following test. Compliance for system C is checked by CC.7.6.9.*

*The test setup for system A is shown in Figure 129. The test setup for system B is shown in Figure 130.*

*The test shall be performed according to the following procedure.*

- 1) Connect the EV supply equipment to a test load with a dedicated EV simulator for the system under test. The setup of the test load for each system is shown in Table AA.10 and BB.7.*
- 2) Measure  $V_{T8}$  and  $A_{T1}$  continuously.*
- 3) Start energy transfer with the procedure specified by the EV supply equipment manufacturer.*
- 4) Record the target current of the EV simulator and  $A_{T1}$  at the operating points as specified in Annex AA and Annex BB. For operating point, see 102.2.5. The target current of the EV simulator is sent to the EV supply equipment via digital communication.*
- 5) During the voltage/current sweep (transition from one OP to another) and for each operating point, check that the difference between  $A_{T1}$  and the target current of the EV simulator is between the limits specified in 101.1.2.1.*

#### **101.1.2.2 Side B voltage regulation in CVM**

For CVM, the maximum voltage deviation, during the pre-charge phase and during the energy transfer stage of the battery system shall be between  $\pm 5\%$  of the target voltage requested by the EV, or  $\pm 2\%$  of the rated maximum voltage of the EV supply equipment at side B, whichever deviation is smaller (see Figure 116).

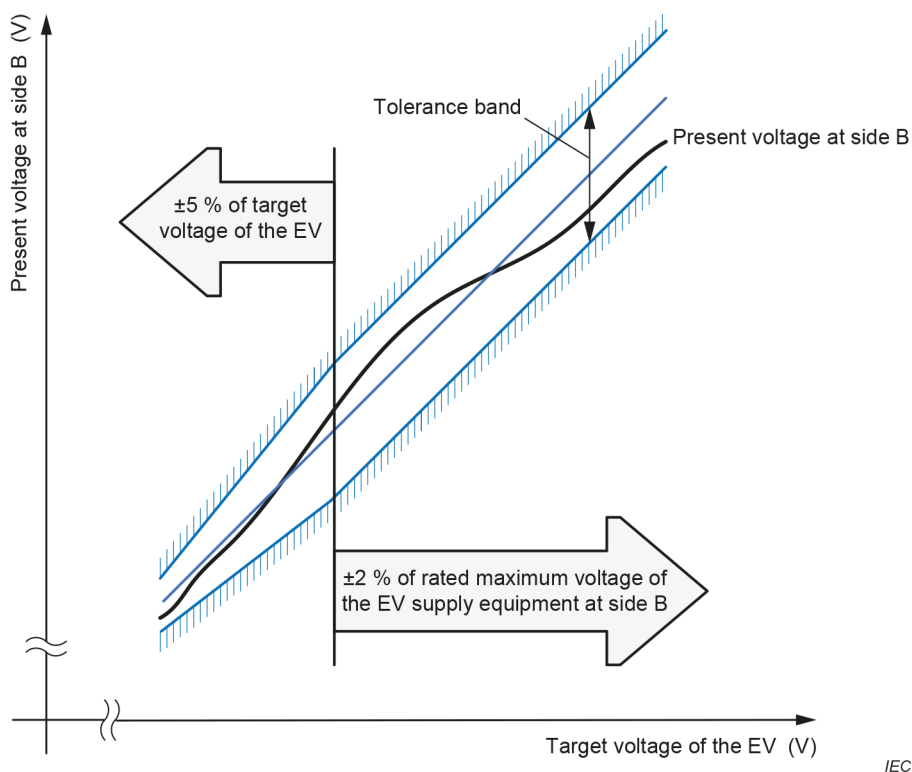

IEC

**Figure 116 – Side B voltage tolerances in CVM**

These requirements shall be fulfilled for system B and system C.

The EV supply equipment shall limit the present current at side B to the target current of the EV with a maximum allowable deviation defined in 101.1.2.1.

*Compliance is checked by the tests in BB.9 and CC.7.6.10.*

NOTE 1 The current ripple is not specified within the CVM as it depends on the impedance between side B and the battery system, which is not defined in ISO 17409.

The current requirements of CCM like regulation (see 101.1.2.1) and control delay (see 101.1.3) are not applicable in CVM, which leads to undefined current behaviour within the CVM.

The EV can prevent the EV supply equipment from unintentionally entering the CVM during energy transfer as this can lead to large current ripples when the battery system is attached, or it can lead to no current if the target voltage of the EV minus the voltage deviation is less than the battery system voltage. When the battery system is attached to side B, the CVM can be avoided by communicating a target voltage of the EV of at least  $V_{\text{Compensation}}$  more than the battery system voltage. See Formula (3).

$$\begin{aligned}
 V_{\text{EV\_Target}} &= V_{\text{compensation}} + V_{\text{Battery}} \\
 V_{\text{compensation}} &= V_{\text{Deviation}} + V_{\text{Ripple}} + V_{\text{EV\_Drop}} + V_{\text{Margin}} \\
 V_{\text{Deviation}} &= \min(2\% \times V_{\text{Rated}}, 5\% \times V_{\text{EV\_Target}}) \\
 V_{\text{Ripple}} &= \max(5 \text{ V DC}, 1\% \times V_{\text{EV\_Target}}) \\
 V_{\text{EV\_Drop}} &= I_{\text{SideB}} \times Z_{\text{EV}}(I_{\text{SideB}})
 \end{aligned}
 \tag{3}$$

where

$V_{EV\_Target}$	is the target voltage of the EV, expressed in volts;
$V_{Compensation}$	is the voltage the EV should add to prevent CVM, expressed in volts;
$V_{Battery}$	is the voltage of the battery system, expressed in volts;
$V_{Deviation}$	is the voltage deviation at side B, expressed in volts;
$V_{Ripple}$	is the voltage ripple at side B, expressed in volts;
$V_{EV\_Drop}$	is the voltage drop between the vehicle connector and the battery system, expressed in volts;
$V_{Margin}$	is the voltage margin chosen by the EV manufacturer, expressed in volts;
$V_{Rated}$	is the rated maximum voltage of the EV supply equipment at side B, expressed in volts;
$I_{SideB}$	is the present current at side B, expressed in ampere;
$Z_{EV}(I_{SideB})$	is the impedance of the EV at the present current at side B, expressed in ohms;
$V_{Deviation} + V_{Ripple}$	is 30 V DC at $V_{Rated} = V_{EV\_Target} = 1\,000$ V DC.

### 101.1.3 Control delay of present current at side B in CCM

If the EV communicated a target current of the EV  $I_{Req\_n}$  different to the previous target current of the EV  $I_{Req\_n-1}$ , the present current at side B shall be between the tolerance limits given in 101.1.2.1 in a delay time  $T_{Transition\ Max}$  or less, as defined in Formula (4), after acknowledging the reception of the target current of the EV according to IEC 61851-24.

$$T_{TransitionMax} = \max \left( 1\text{ s}, \frac{|I_{Req\_n} - I_{SideB}(t_0)|}{20 \frac{\text{A}}{\text{s}}} \right) \quad (4)$$

where

$T_{TransitionMax}$	is the maximum transition time to the tolerance band of the new target current, expressed in seconds;
$I_{Req\_n}$	is the value for the acknowledged target current of the EV, expressed in ampere;
$I_{SideB}(t_0)$	is the value for the present current at side B at the moment $I_{Req\_n}$ is acknowledged, expressed in ampere.

NOTE For system A and system B, the acknowledgement refers to the ACK field in the CAN frames. For system C, the acknowledge refers to the ACK in TCP.

The value of 20 A/s in Formula (4) is chosen to allow the EV supply equipment to limit the dynamics of the load change imposed on the supply network if the supply network cannot tolerate faster load changes. However, it is recommended that the EV supply equipment support a current change rate  $> 20$  A/s, that is, much shorter transition times than calculated by Formula (4), in order to shorten the response time to user interactions like starting and stopping the communication session, if the EV supply equipment is installed at a site where the supply network can tolerate such faster load changes.

During an increasing current transition, the present current at side B shall be

- less than the upper tolerance and ripple limits of the target current of the EV ( $I_{Req\_n}$ ), according to 101.1.2.1 and 101.1.5, and
- more than the lower tolerance and ripple limits of the present current at side B at the time the new target current of the EV was communicated ( $I_{SideB}(t_0)$ ), according to 101.1.2.1 and 101.1.5.

Figure 117 shows an example of a worst-case scenario for an increasing current transition, where the present current at side B reaches the upper and lower tolerance and ripple limits.

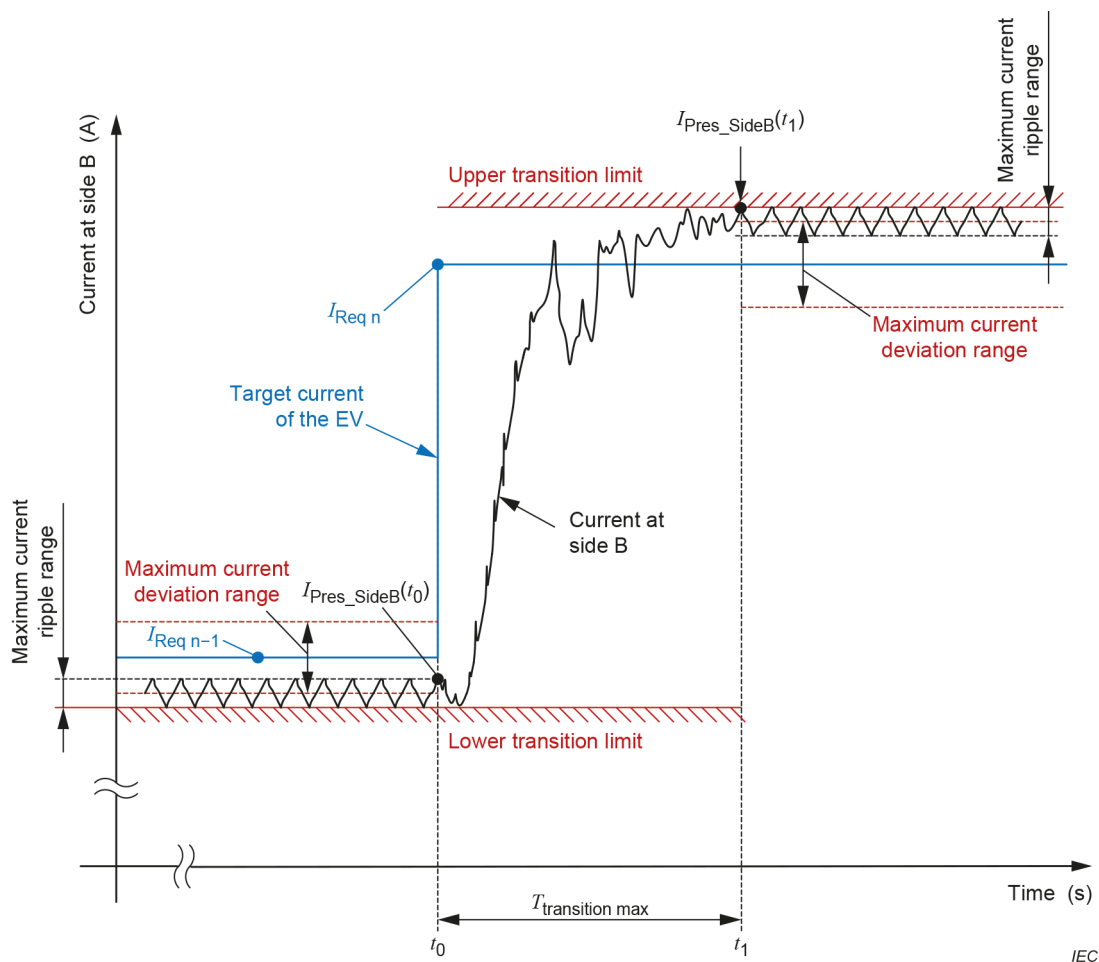
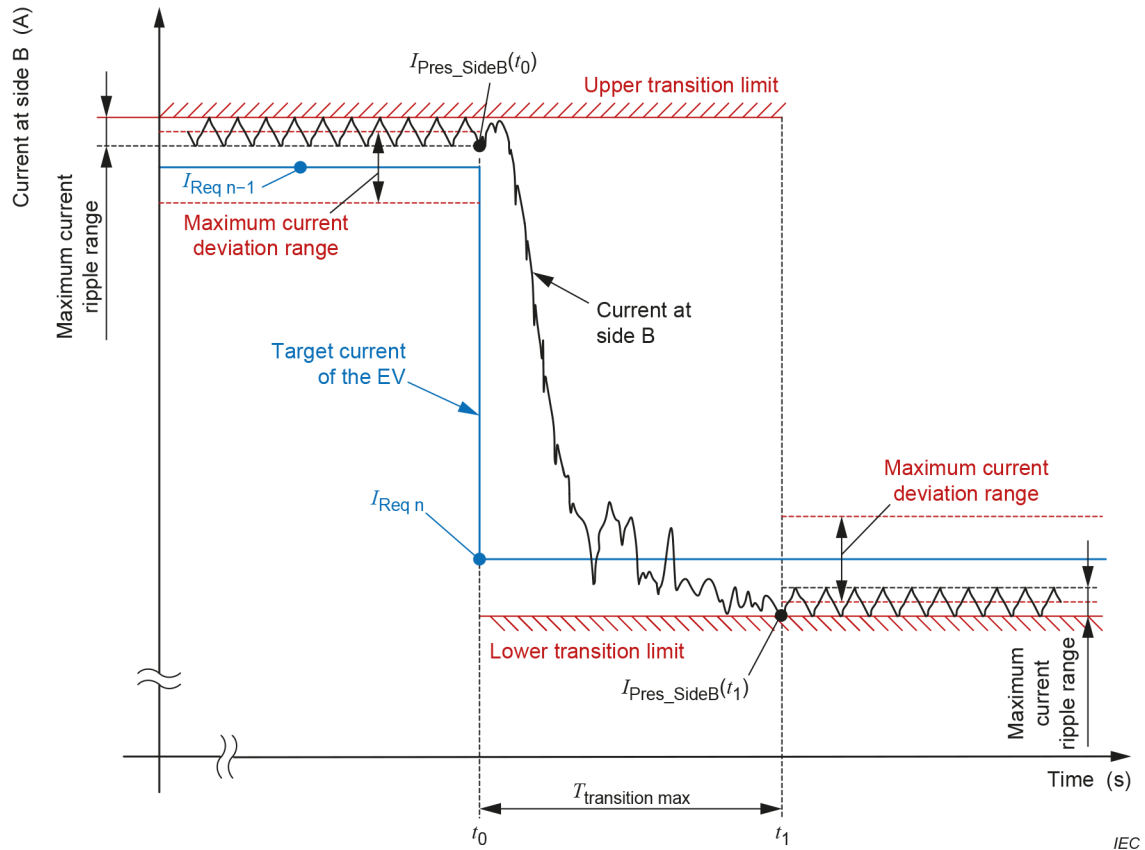

**Figure 117 – Current control delay for an increasing current request**

During a decreasing current transition, the present current at side B shall be

- less than the upper tolerance and ripple limits of the present current at side B at the time the new target current of the EV was communicated ( $I_{SideB}(t_0)$ ), according to 101.1.2.1 and 101.1.5, and
- more than the lower tolerance and ripple limits of the target current of the EV ( $I_{Req\_n}$ ), according to 101.1.2.1 and 101.1.5.

Figure 118 shows an example of a worst-case scenario for a decreasing current transition, where the present current at side B reaches the upper and lower tolerance and ripple limits.



**Figure 118 – Current control delay for a decreasing current control request**

Compliance for system A and system B is checked by the following test. For system C, see CC.7.6.12.

The test setup for system A is shown in Figure 129. The test setup for system B is shown in Figure 130.

- 1) Connect the EV supply equipment to a test load with a dedicated EV simulator for the system under test, operating in CCM.
- 2) The time of the EV simulator sending the target current of the EV simulator shall be recorded, and  $A_{T1}$  in a certain period of time shall be also recorded.
- 3) The EV communicated a target current.
  - Deviation is  $\leq 20$  A DC.
  - Deviation is  $> 20$  A DC.
- 4) For system A, change the operating point (see Figure 133) from
  - OP1 to OP3, OP4, OP5, OP6, OP7,
  - OP2 to OP3, OP4, OP5, OP6, OP7,
  - OP3, OP4, OP5, OP6, OP7 to OP1, and
  - OP3, OP4, OP5, OP6, OP7 to OP2.

For system B, change the operating point (see Figure BB.5) from

- OP1 to OP5,
- OP2 to OP3, OP4 (only for type II EV supply equipment),
- OP5 to OP1, and
- OP4 (only for type II EV supply equipment), OP3 to OP2.

- 5) *The EV supply equipment shall control the present current at side B*
- *in 1 s or less after the target current of the EV simulator has been communicated, and*
  - *in a delay time  $T_{Transition\_Max}$  or less as defined in Formula (4), and as shown in Figure 117 and Figure 118.*

#### **101.1.4 Descending rate of present current at side B**

The descending rates of the present current at side B for error shutdown and emergency shutdown shall be according to the timing and present current at side B restrictions specified in AA.4.3.5 and AA.5 for system A, BB.5.1 for system B and CC.3.4 for system C.

*For system C, compliance is checked by the respective error or emergency shutdown test case in Annex CC. See Table CC.10.*

*Compliance for system A and system B is checked by the following test.*

*The test setup for system A is shown in Figure 129. The test setup for system B is shown in Figure 130.*

*This test shall simulate the stop charge command from EV, to detect the changes of the present current at side B during the energy transfer stage.*

*The test shall be performed according to the following procedure.*

- 1) *Connect the EV supply equipment to a test load with a dedicated EV simulator for the system under test, operating in CCM.*
- 2) *The time of the EV control simulator sending the target current of the EV simulator shall be recorded, and  $A_{\gamma 1}$  in a certain period of time shall be also recorded.*
- 3) *For normal operation:*
  - *for system A: change the operating point from OP1, OP2, OP3, OP4, OP5, OP6 and OP7 to a present current at side B < 5 A DC;*
  - *for system B without the function of CPM: change the operating point from OP1, OP2, OP3 and OP5 to a present current at side B < 5 A DC (for type I EV supply equipment);*
  - *for system B with the function of CPM: change the operating point from OP1, OP2, OP3, OP4 and OP5 to a present current at side B < 5 A DC (for type II EV supply equipment).*
- 4) *For emergency shutdown:*
  - *for system A: perform the emergency shutdown from OP1, OP2, OP3, OP4, OP5, OP6 and OP7;*
  - *for system B without the function of constant power sharing: perform the emergency shutdown from OP3 (for a type I EV supply equipment);*
  - *for system B with the functions of constant power sharing: perform the emergency shutdown from OP4 (for a type II EV supply equipment).*
- 5) *Check that the system specific requirements for error or emergency shutdown test are met.*

#### **101.1.5 Periodic and random deviation (current ripple at side B during CCM)**

The present current ripple at side B during CCM shall be less than or equal to the limit as defined in Table 118. The measurement shall be made at the rated maximum power of the EV supply equipment at side B and the rated boost current of the EV supply equipment at side B, or in the worst case where the present voltage at side B and present current at side B correspond theoretically to the maximum current ripple at side B. The current ripple at side B is not included in the present current tolerance defined in 101.1.2.1.

**Table 118 – Current ripple limit of the EV supply equipment**

Frequency <sup>a</sup>	Present current at side B ( <i>I</i> )		
	<i>I</i> ≤ 200 A DC <sup>d</sup>	200 A DC < <i>I</i> ≤ 400 A DC	<i>I</i> > 400 A DC
10 Hz	1,5 <sup>c</sup>	$I \times 0,75 \% ^c$	3,0 <sup>b</sup>
			$I \times 0,75 \% ^c$
5 kHz	$(I \times 1,5 \% + 3) ^b$	6,0 <sup>c</sup>	$I \times 1,5 \% ^c$
	6,0 <sup>c</sup>		
150 kHz	9,0 <sup>c</sup>	$I \times 4,5 \% ^c$	18,0 <sup>b</sup>
			$I \times 4,5 \% ^c$

<sup>a</sup> Cut-off frequency of the first order low pass filter.

<sup>b</sup> Recommended limit in  $A_{\text{peak-to-peak}}$ .

<sup>c</sup> Absolute maximum limit in  $A_{\text{peak-to-peak}}$ .

<sup>d</sup> For system B, ≤ 250 A DC.

NOTE 1 System A supports a present current at side B ≤ 400 A DC.

NOTE 2 System B supports a present current at side B ≤ 250 A DC.

For CCM, when the battery system is not connected: under consideration.

Compliance for system A and system B is checked by the following test. Compliance for system C is checked by CC.7.6.9.

The test setup for system A is shown in Figure 129. The test setup for system B is shown in Figure 130.

The test load according to Figure 132 shall be used.

- 1) Connect the EV supply equipment to a test load with a dedicated EV simulator for the system under test, with a designated smoothing capacitor.
- 2) The EV supply equipment shall operate at proper operating points for the test (see Figure 133).
- 3) Measure  $A_{T1}$  to define the current ripple at side B of each frequency bands specified in Table 118.

System specific test condition are given below.

- For system A, see AA.3.11.
- For a system B type I EV supply equipment, only OP3 shall be checked. For a system B type II EV supply equipment, OP3 and OP4 shall be checked.

#### 101.1.6 Periodic and random deviation (voltage ripple at side B during CVM)

For a target voltage of the EV ≤ 500 V DC, the maximum voltage ripple at side B in normal operation and pre-charge phase, if applicable, shall be between ±5 V.

For a target voltage of the EV > 500 V DC, the maximum voltage ripple at side B in normal operation and pre-charge phase, if applicable, shall be between ±1 % of the target voltage of the EV.

The voltage ripple at side B is not included in the tolerance defined in 101.1.2.2.

The maximum voltage slew rate in normal operation shall be between  $\pm 20$  V/ms.

For explanation of terms, see Figure 119.

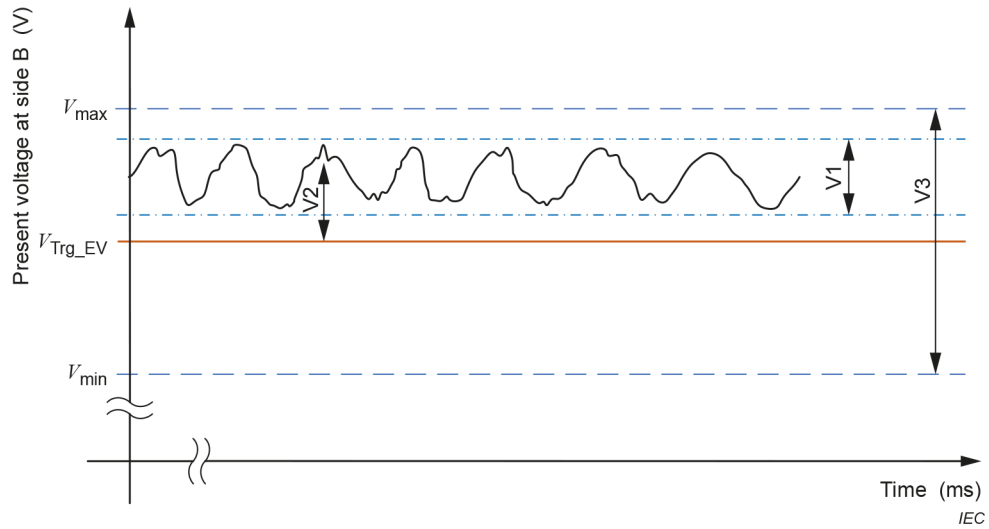

a) Voltage at side B between DC+ and DC– during normal operation (between limits)

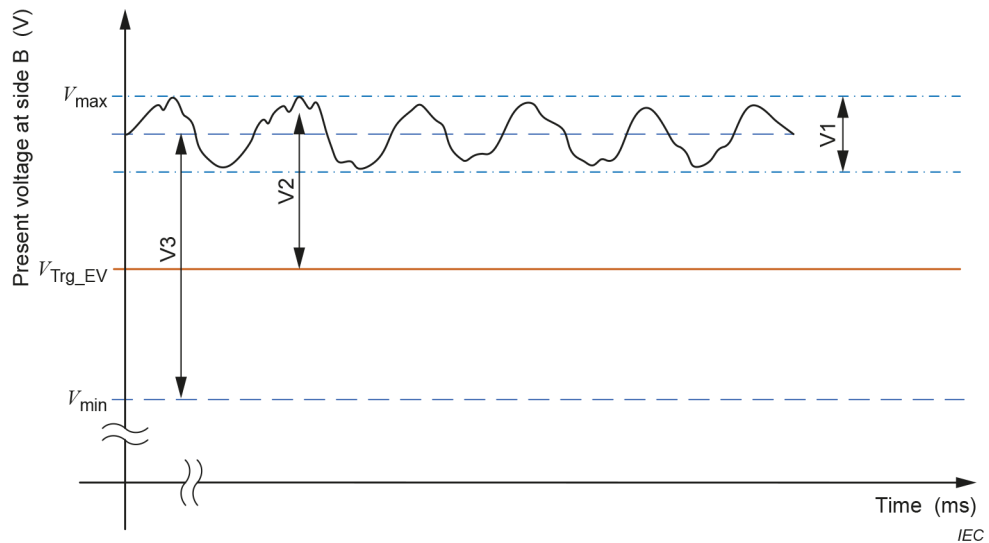

b) Voltage at side B between DC+ and DC– during normal operation (worst case scenario)

**Key**

$V_{Max}$	$V_{EV Request} + V_{Deviation}$	V1	voltage ripple range
$V_{EV Request}$	target voltage of the EV	V2	voltage deviation
$V_{Min}$	$V_{EV Request} - V_{Deviation}$	V3	maximum allowed voltage deviation

**Figure 119 – Voltage at side B in CVM operation in steady state with ripple**

Compliance is checked by BB.10 and CC.7.6.10.

For CVM, when the battery system is not connected: under consideration.

### 101.1.7 Load dump

If the EV disconnection devices open during energy transfer at the rated boost current of the EV supply equipment at side B, the present voltage at side B shall be less than or equal to the limit specified for each system in AA.3.12, BB.5.7 or CC.6.1.

*Compliance is checked by AA.3.12 for system A, BB.5.7 for system B and CC.7.6.7 for system C.*

### 101.1.8 Side B inductance

It is recommended to limit the side B inductance of the EV supply equipment in order to limit the effects imposed on the EV and the EV supply equipment during a load dump scenario, as well as during a short-circuit scenario.

The value for the side B inductance limit is under consideration.

The side B inductance can be measured by the following method.

The EV supply equipment should be provided in the configuration that results in the highest side B inductance, for example, maximum side B cable assembly length, maximum distance between the PEC and the vehicle connector, and other factors. The highest side B inductance configuration should only include configurations allowed by the installation manual. This configuration should then be used for this measurement method.

The EV supply equipment should be connected to a test load as shown in Figure 120 and a dedicated EV simulator for each system.

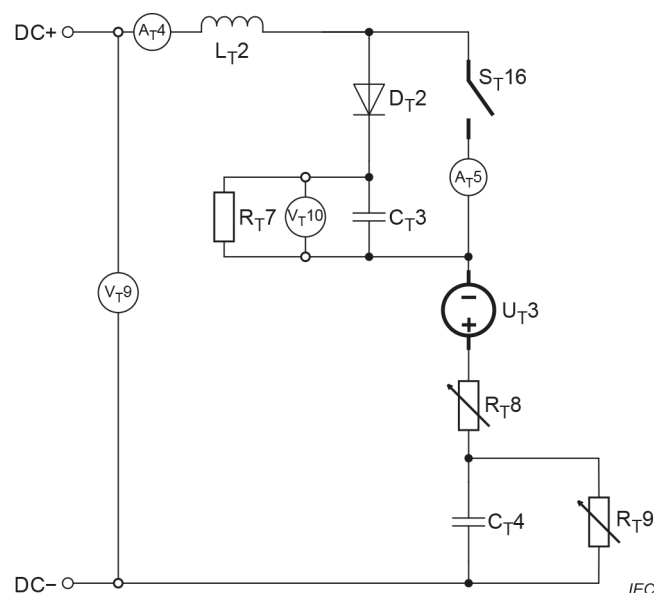

**Figure 120 – Setup to measure the maximum side B inductance**

The switch  $S_{T16}$  should be a semiconductor or several semiconductors in parallel such that the switch will open in less than  $1 \mu\text{s}$ . The value for  $C_{T3}$  should be between  $1 \mu\text{F}$  and  $100 \mu\text{F}$ , based on the test current and the semiconductors used in parallel. The value for  $R_{T7}$  should be  $> 100 \text{ k}\Omega$ . The values for  $U_{T3}$ ,  $R_{T8}$ ,  $R_{T9}$ , and  $C_{T4}$  should be as shown in Table 120.

$L_{T2}$ , represents the load inductance and should be measured before completing the measurement method.

- 1) The EV supply equipment should operate at a test point equal to OP7 in CCM.
- 2) Once the test point has been reached, measure the present current at side B,  $A_{T4}$ , immediately before opening switch  $S_{T16}$ .
- 3) The semiconductor, switch  $S_{T16}$ , is then opened.
- 4) After opening switch  $S_{T16}$ , the maximum voltage across the capacitor  $C_{T3}$ ,  $V_{T10}$ , is measured for a duration of  $t_{\text{Measure}}$  with a cut-off frequency of  $\geq 2$  MHz, and a minimum sampling of 10 Mega samples per second. The maximum voltage measured is to be used. The value of  $t_{\text{Measure}}$  should be determined by Formula (5):

$$t_{\text{Measure}} = 6 \times \sqrt{L_{\text{exp}} \times C_{T3}} \quad (5)$$

where

$t_{\text{Measure}}$  is the measurement duration, expressed in seconds;

$L_{\text{exp}}$  is the maximum expected value of inductance, expressed in henry;

$C_{T3}$  is the value of the  $C_{T3}$  capacitor, expressed in farad.

- 5) Once these measurements are complete,  $L_{\text{Calculated}}$  should be determined by Formula (6).

$$L_{\text{Calculated}} = \left( V_{T10}^2 / A_{T4}^2 \times C_{T3} \right) - L_{T2} \quad (6)$$

where

$L_{\text{Calculated}}$  is the calculated side B inductance, expressed in henry;

$V_{T10}$  is the maximum voltage measured on  $C_{T3}$ , expressed in volts;

$A_{T4}$  is the present current at side B, expressed in ampere;

$C_{T3}$  is the  $C_{T3}$  capacitance, expressed in farad;

$L_{T2}$  is the  $L_{T2}$  inductance, expressed in henry.

## 101.2 Specific requirement for energy transfer with a thermal management system or thermal sensing only

### 101.2.1 General

Subclause 101.2 is applicable for system A and system C. For system B: under consideration.

For energy transfer with a thermal management system, the EV supply equipment shall be equipped with a side B cable assembly according to IEC TS 62196-3-1.

### 101.2.2 Temperature limits and self-diagnostics

#### 101.2.2.1 Temperature of the DC contact assembly of the vehicle connector

The EV supply equipment shall ensure that the temperature of the DC contact assembly of the vehicle connector complies with the following requirements under the operating ambient temperature  $\leq 40$  °C.

- The absolute temperature of the DC contact assembly shall be  $\leq 90$  °C.

- The surface temperature of the side B cable assembly shall be less than or equal to the temperature limits according to IEC 62196-1:2022, 16.5.
- The EV supply equipment shall react on the behaviour of the thermal sensing device (temperature sensor or thermal protective fuse) at the DC contact assembly.

#### **101.2.2.2 Requirements for self-diagnostics function for thermal management system**

The EV supply equipment manufacturer shall perform a failure modes and effects analysis (FMEA) according to IEC 60812 to show conformity with 101.2.2.2.

The EV supply equipment shall provide appropriate means to reduce the likelihood of a hazard occurring in case of a first fault in the thermal management system.

*EXAMPLE* By double or reinforced insulation, flow rate, pressure, temperature, level of coolant, etc.

In case of a thermal exchange device or thermal transport device failure (for example, failure of cooling pump, jammed cooling hose), the EV supply equipment shall either trigger a shutdown or reduce the applicable maximum current of the EV supply equipment at side B to a value for operation without thermal exchange and/or thermal transport, if such a value is specified by the side B cable assembly manufacturer. The EV supply equipment shall communicate it to EV via digital communication.

In case of a thermal sensing fault, see 101.2.3.3.

*Compliance is checked by inspection and test in 101.2.4.4.*

### **101.2.3 Temperature monitoring**

#### **101.2.3.1 General**

The EV supply equipment using a side B cable assembly providing thermal sensing data shall have measures to continually monitor the provided temperature data.

The EV supply equipment shall continuously monitor the temperature data of the DC contact assemblies during the complete communication session.

#### **101.2.3.2 Overtemperature handling**

If the contact temperature of the DC contact accessory is  $> 90\text{ °C}$  for 8 consecutive seconds, the EV supply equipment shall trigger an error shutdown in 1 s or less according to AA.4.3.5 for system A and CC.3.4 for system C.

If the contact temperature of the DC contact accessory is  $> 95\text{ °C}$  for 1 s, the EV supply equipment shall trigger an error shutdown in 1 s or less.

*Compliance is checked by test in 101.2.4.3.*

For system A, if three consecutive error shutdowns occur due to temperature more than the manufacturer's specified limit at one or both DC contacts, the EV supply equipment shall not start a new communication session until serviced by a skilled person.

*Compliance is checked by inspection and measurement.*

### **101.2.3.3 Check of the plausibility of the values provided by the thermal sensing devices**

A plausibility check of the thermal sensing devices of the vehicle connector shall be done prior to each communication session. If the plausibility check fails, the EV supply equipment shall only operate under the current assigned by the side B cable assembly manufacturer for operation without thermal exchange and/or thermal transport.

*Compliance is checked by inspection and test in 101.2.4.5.2.*

If the thermal sensing of a DC contact assembly sends no or an implausible signal during energy transfer, the EV supply equipment shall reduce the applicable maximum current of the EV supply equipment at side B to the current assigned by the side B cable assembly manufacturer for operation without thermal exchange and/or thermal transport or trigger an error shutdown according to AA.3.8.1 and CC.3.4 in 9 s or less.

*Compliance is checked by inspection and test in 101.2.4.5.3.*

## **101.2.4 Tests for thermal management system performance of the EV supply equipment**

### **101.2.4.1 General**

*For all tests, thermal stabilisation is considered to have occurred when three successive readings, taken at intervals of 10 min or more, indicate an increase of  $\leq 2$  K.*

*The test current is the rated boost current of the EV supply equipment at side B according to the device under test (DUT) manufacturer's data sheet, if not stated otherwise.*

*The DUT for these tests is the EV supply equipment.*

*A system specific EV simulator equipped with a current sink shall be used for all tests in 101.2.4.*

*Each test shall be performed with a corresponding test accessory, called reference device (RD), which mates with the vehicle connector.*

*The material for all reference devices shall be Cu-ETP.*

*For system A, all tests, except the test of overtemperature handling according to 101.2.4.3, shall be performed with an RD according to Figure 121 and a test arrangement according to Figure 122. The test for overtemperature handling according to 101.2.4.3 shall be performed with an RD according to Figure 123 and a test arrangement according to Figure 124.*

*For system C, all tests, except the test of overtemperature handling according to 101.2.4.3, shall be performed with an RD according to Figure 125 and a test arrangement according to Figure 126. The test for overtemperature handling according to 101.2.4.3 shall be performed with an RD according to Figure 127 and a test arrangement according to Figure 128.*

*The contact resistances of the reference devices, including DC contact, contact body, mechanical joining and 150 mm of the attached conductor, measured by four-terminal sensing according to Figure 121 and Figure 125, shall comply with the values indicated in Table 119.*

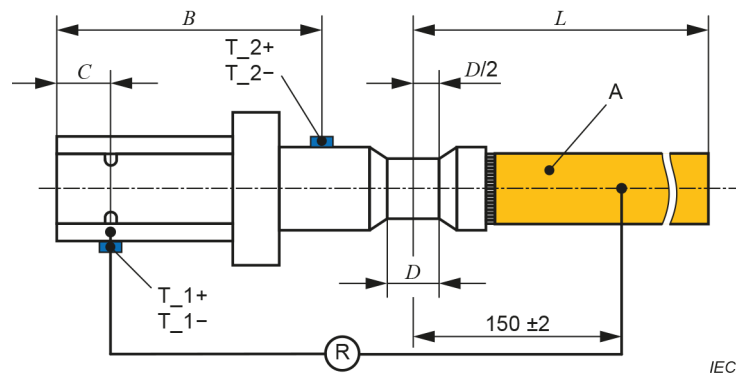
**Key**

- T<sub>1</sub>, T<sub>2</sub> temperature sensors on the reference device (RD)
- A conductor cross-section (depending on the test current, see Table 119)
- B length to be specified by the side B cable assembly manufacturer
- C length to be specified by the side B cable assembly manufacturer
- D length to be specified by the side B cable assembly manufacturer
- L length of attached conductor (see Table 119)
- R resistance measurement (see Table 119 for values)

NOTE All values are in mm. For missing dimensions, see IEC 62196-3:2022, standard sheet 3-1a.

**Figure 121 – Reference device (RD) A<sub>0</sub>**

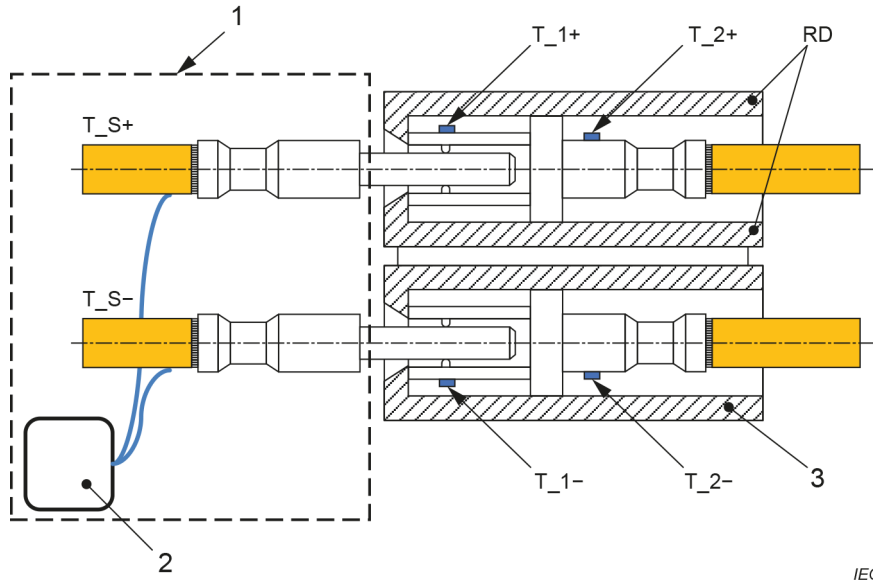

**Key**

- 1 device under test (vehicle connector)
- 2 thermal exchange device, if any
- 3 housing and support for RD assembly
- RD reference device AA\_0
- T\_S+, T\_S- thermal sensing device of the vehicle connector at DC+ and DC-
- T\_1+, T\_2+, T\_1-, T\_2- thermal sensors of the reference device

NOTE For missing dimensions, see IEC 62196-3:2022, standard sheet 3-1a.

**Figure 122 – Test arrangement A\_0**

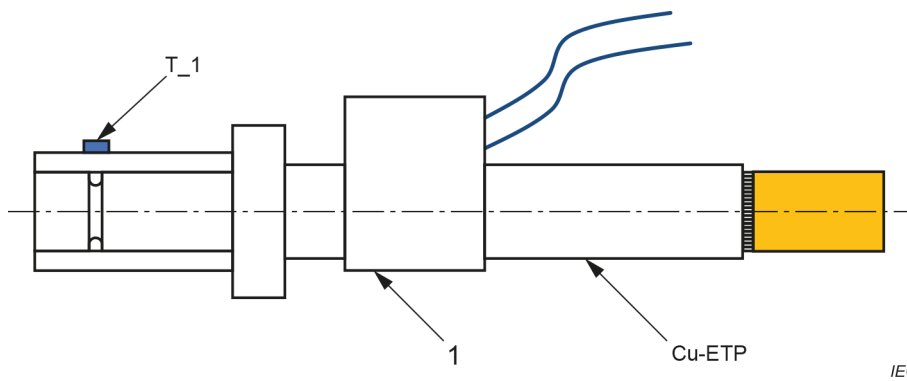

**Key**

- 1 heating unit (minimum of 50 W is recommended)
- T\_1 temperature sensor attached to DC+/ DC-
- Cu-ETP electrolytic tough-pitch copper (99,9 % purity)

NOTE For missing dimensions, see IEC TS 62196-3-1:2020, standard sheet 3-1a.

**Figure 123 – Reference device RD A\_1**

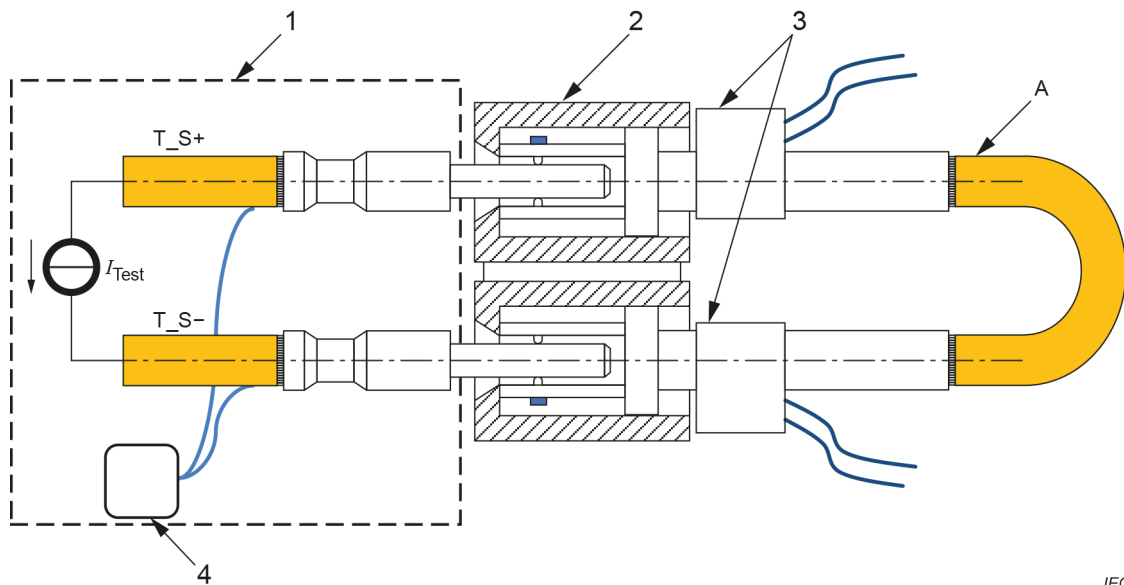

IEC

**Key**

- 1 device under test (vehicle connector)
- 2 mating face according to IEC 62196-3:2022, standard sheet 3-la
- 3 reference device AA\_1
- 4 thermal exchange device, if any
- T<sub>S+</sub>, T<sub>S-</sub> thermal sensing device inside the vehicle connector at DC+ and DC-
- T<sub>1+</sub>, T<sub>2-</sub> thermal sensors of the reference device
- A conductor cross section
- I<sub>Test</sub> source for test current

NOTE For missing dimensions, see IEC 62196-3:2022, standard sheet 3-la.

**Figure 124 – Test arrangement A\_1**

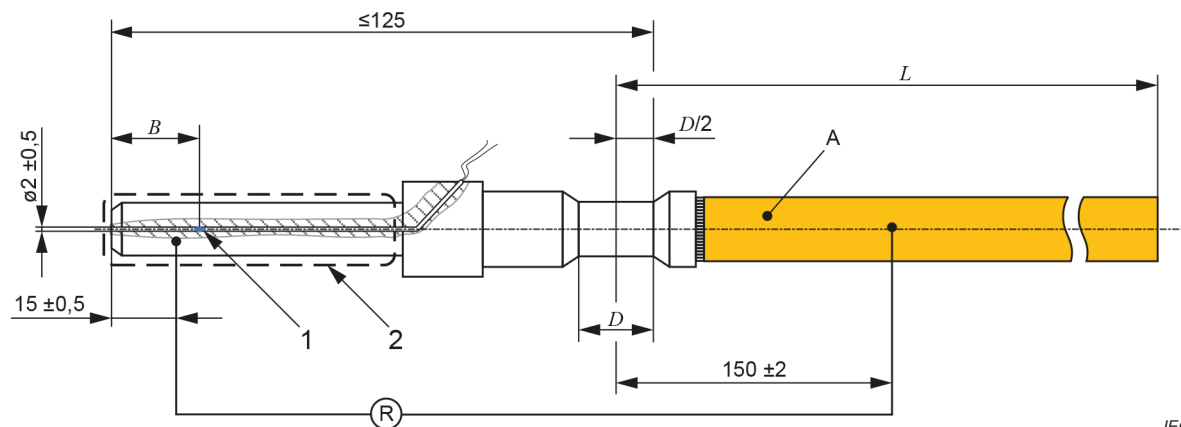

IEC

**Key**

- 1 reference temperature sensor
- 2 DC+/DC- contacts according to IEC 62196-3:2022, standard sheet 3-IIIa (configuration EE) or standard sheet 3-IVa (configuration FF)
- A conductor cross-section (depending on the test current, see Table 119)
- B 12 mm ± 1 mm for configuration EE, 18 mm ± 1 mm for configuration FF
- D to be specified by the side B cable assembly manufacturer
- L length of attached conductor (see Table 119)
- R resistance measurement (see Table 119 for values)

**Figure 125 – Reference device RD C\_0**

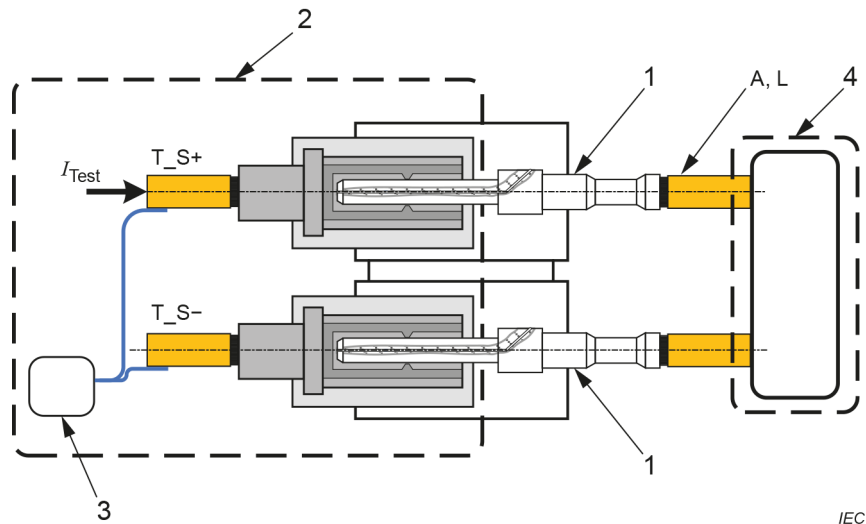
**Key**

- 1 reference device C\_0
- 2 device under test (vehicle connector)
- 3 thermal exchange and thermal transfer, if any
- 4 EV simulator with current sink
- A conductor cross-section (depending on the test current, see Table 119)
- L length of attached conductor (see Table 119)
- $I_{Test}$  test current
- T\_S+, T\_S– thermal sensing device inside vehicle connector at DC+ and DC–

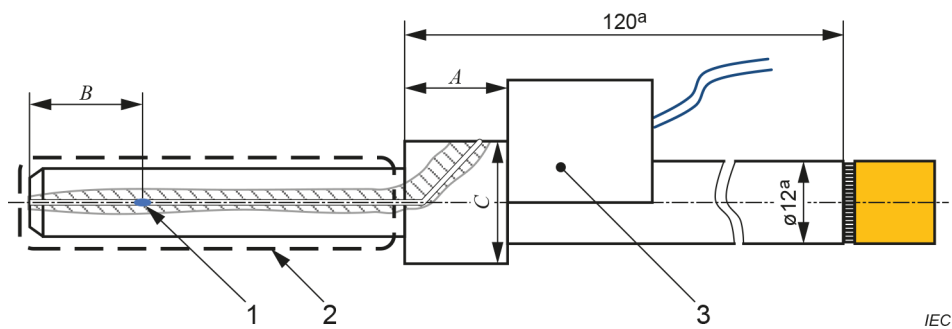
**Figure 126 – Test arrangement C\_0****Key**

- 1 reference temperature sensor
- 2 DC+/DC– contacts according to IEC 62196-3:2022, standard sheet 3-IIIa (configuration EE) or standard sheet 3-IVa (configuration FF)
- 3 heating unit
- A to be specified by the side B cable assembly manufacturer
- B 12 mm ± 1 mm for configuration EE, 18 mm ± 1 mm for configuration FF
- C to be specified by the side B cable assembly manufacturer

<sup>a</sup> The diameter and length of termination (Ø12 and 120) are recommended values.

**Figure 127 – Reference device RD C\_1**

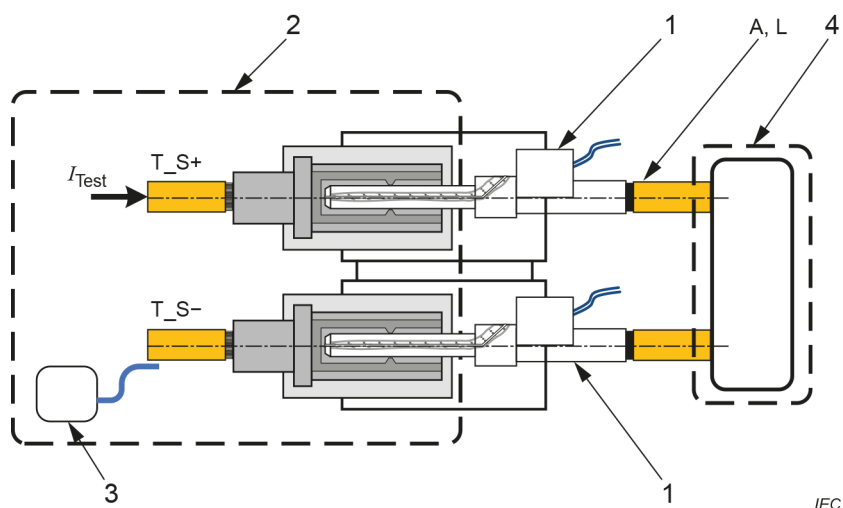

**Key**

- 1 reference device C\_0
- 2 DUT
- 3 EV supply equipment with thermal exchange and thermal transfer, if any
- 4 EV simulator with current sink
- A conductor cross-section (depending on the test current, see Table 119)
- L length of attached conductor (see Table 119)
- $I_{Test}$  test current
- T\_S+, T\_S- thermal sensing device inside vehicle connector at DC+ and DC-

**Figure 128 – Test arrangement C\_1**

Values for wiring cross section and cable length are specified in Table 119.

**Table 119 – Test parameter values**

Conductor cross section A	Rated boost current of the EV supply equipment at side B			Resistance	
	System A		System C	System A	System C <sup>a, b</sup>
	Non-cooled	Cooled			
mm <sup>2</sup>	A	A	A	μΩ	μΩ
35	125	150	100	As specified by the side B cable assembly manufacturer	n.a.
50	150	200	200		≥ 123
70	200	300	300		≥ 91
95	300	400	400		≥ 65
120	350	n.a.	500		≥ 57
150	400	n.a.	n.a.		n.a.

*L* Cable length ≥ 2 m.  
<sup>a</sup> All strands to be connected during resistance measurement.  
<sup>b</sup> Resistance values at 25 °C.

**101.2.4.2 Thermal management system performance test**

This test is applicable for EV supply equipment according to system A and system C using a thermal management system.

*For system A, the test is performed with an RD according to Figure 121 and a test arrangement according to Figure 122.*

*For system C, the test is performed with an RD according to Figure 125 and a test arrangement according to Figure 126.*

*The test setup for system A is shown in Figure 129. The test setup for system C is shown in Figure 131.*

*The test shall be executed as follows.*

- 1) *The DUT shall be stored for 2 h or more at  $40\text{ °C} \pm 4\text{ °C}$ .*
- 2) *The test shall be executed at  $40\text{ °C} \pm 4\text{ °C}$  ambient temperature and at rated continuous current of the EV supply equipment at side B. If the DUT provides temperature-controlled energy transfer (see 101.3), the test shall be performed including the rated boost current of the EV supply equipment at side B according to the data sheet of the DUT. This is accomplished by performing the test at rated boost current of the EV supply equipment at side B and then decreasing to the rated continuous current of the EV supply equipment at side B until thermal stabilization.*
- 3) *Once thermal stabilisation has been reached, the DUT shall be operated at the rated continuous current of the EV supply equipment at side B for an additional 60 min.*
- 4) *The current  $A_{T1}$  shall be  $< 2\text{ A DC}$ .*
- 5) *The temperatures measured by the reference temperature sensors of the RD shall be monitored with one or more samples per second throughout the test.*
- 6) *This test is passed, if*
  - *the EV supply equipment performs the energy transfer stage without any errors,*
  - *the measured temperatures by the reference temperature sensors are  $\leq 90\text{ °C}$ , and*
  - *the temperature at any touchable and graspable surface of the DUT (for system C only) or the temperature limits according to Clause AA.9 (for system A only) is less than or equal to the temperature limits according to IEC 62196-1:2022, 16.5.*

#### **101.2.4.3 Tests of overtemperature handling**

*This test is applicable for EV supply equipment according to system A and system C using thermal management system.*

*For system A, the test is performed with an RD according to Figure 123 and a test arrangement according to Figure 124.*

*For system C, the test is performed with an RD according to Figure 127 and a test arrangement according to Figure 128.*

*The test setup for system A is shown in Figure 129. The test setup for system C is shown in Figure 131.*

*The test shall be executed as follows.*

- 1) *The DUT shall be stored for 2 h or more at  $40\text{ °C} \pm 4\text{ °C}$ .*
- 2) *The DUT is then energized. The current  $A_{T1}$  shall be the rated continuous current of the EV supply equipment at side B. The voltage  $V_{T8}$  for this test can be any voltage allowed by the EV supply equipment.*

- 3) *Temperatures are monitored on the DC+ and DC– contacts of the vehicle connector, and once thermal stabilization has been reached, the over-temperature of the vehicle connector is simulated by applying heat power ensuring a constant temperature rise of  $2,5 \pm 0,5$  K/min (measured by the reference temperature sensor) on the DC+ contact of the vehicle connector.*
- 4) *The DUT shall*
  - *perform an error shutdown sequence according to AA.4.3.5 for system A and CC.3.4 for system C in 9 s or less after the reference temperature sensor signals a temperature of  $> 90$  °C, and*
  - *reduce the present current at side B to 2 A DC before the temperature measured by the reference temperature sensor reaches 90 °C.*
- 5) *The DC+ and DC– contacts of the vehicle connector of the DUT are allowed to cool until a temperature of  $40$  °C  $\pm$  4 °C is reached.*
- 6) *Step 2) and step 3) shall be repeated with heat power applied on the DC– contact of the vehicle connector. The DUT shall react in accordance with step 4).*
- 7) *The DC+ and DC– contacts of the vehicle connector of the DUT are allowed to cool until a temperature of  $40$  °C  $\pm$  4 °C is reached.*
- 8) *Step 2) through step 6) are repeated.*

#### **101.2.4.4 Test for self-diagnostics function for thermal management system**

*This test is applicable for EV supply equipment according to system A and system C using thermal management system. For system A, the test is performed with an RD according to Figure 121 and a test arrangement according to Figure 122. For system C, the test is performed with an RD according to Figure 125 and a test arrangement according to Figure 126.*

*The test setup for system A is shown in Figure 129. The test setup for system C is shown in Figure 131.*

*The test shall be executed as follows.*

- 1) *The DUT shall be stored for 2 h or more at  $40$  °C  $\pm$  4 °C.*
- 2) *The DUT is then energized. The current  $A_{T1}$  shall be rated continuous current of the EV supply equipment at side B. The voltage  $V_{T8}$  for this test can be any voltage allowed by the EV supply equipment.*
- 3) *The test shall be executed for the following test sequences.*
  - *Sequence a) : Once thermal stabilization has been reached, the thermal transport device, for example, cooling pump, shall be switched off.*
  - *Sequence b): Once thermal stabilization has been reached, the thermal exchange device, for example, cooling unit, shall be switched off.*
- 4) *After switching off the corresponding device, the DUT shall be operated for an additional 60 min.*
- 5) *This test is passed if*
  - *the measured temperatures by the reference temperature sensors are  $\leq 90$  °C, and*
  - *the temperature at any touchable and graspable surface of the DUT (for system C only) or the temperature limits according to Clause AA.9 (for system A only) are less than or equal to the temperature limits according to IEC 62196-1:2022, 16.5.*

NOTE Pass criteria can be achieved by reducing the available maximum current of the EV supply equipment at side B.

#### **101.2.4.5 Test for availability of thermal sensing devices**

##### **101.2.4.5.1 General**

*For system A, the test is performed with an RD according to Figure 121 and a test arrangement according to Figure 122.*

*For system C, the test is performed with an RD according to Figure 125 and a test arrangement according to Figure 126.*

*The DUT shall be equipped with a disconnection device in each signalling path of thermal sensing.*

*Tests shall be conducted for each of the following test setups:*

- signalling path of thermal sensing on DC+ contact of the vehicle connector open and signalling path of thermal sensing on DC– contact of the vehicle connector closed;*
- signalling path of thermal sensing on DC+ contact of the vehicle connector closed and signalling path of thermal sensing on DC– contact of the vehicle connector open.*

##### **101.2.4.5.2 Test for availability of thermal sensing devices before energy transfer**

*The test shall be executed as follows.*

- 1) The availability of each thermal sensing device shall be checked before each communication session.*
- 2) After setting the disconnection devices in the positions according to 101.2.4.5.1, a communication session shall be initiated.*
- 3) This test is passed if the DUT*
  - performs a communication session with the current specified by the side B cable assembly manufacturer for operation without thermal exchange and/or thermal transport, or*
  - does not perform a communication session until serviced by a skilled person.*

##### **101.2.4.5.3 Test for availability of thermal sensing devices during energy transfer**

*The test setup for system A is shown in Figure 129. The test setup for system C is shown in Figure 131.*

*The test shall be executed as follows.*

- 1) The DUT is energized. The current  $A_{T1}$  shall be the rated continuous current of the EV supply equipment at side B. The voltage  $V_{T8}$  for this test can be any voltage allowed by the EV supply equipment.*
- 2) Then, the EV disconnection devices shall be set in the positions according to 101.2.4.5.1.*
- 3) This test is passed if the DUT reduces the present current at side B to the current assigned by the side B cable assembly manufacturer for operation without thermal exchange and/or thermal transport or triggers an error shutdown according to AA.4.3.5 or CC.3.4 in 9 s or less after the occurrence of the fault.*

#### **101.3 Specific requirements for temperature-controlled energy transfer**

Subclause 101.3 is applicable for system A and system C. For system B: under consideration.

Additional requirements for system A are specified in AA.3.16.

The EV supply equipment may allow a rated boost current of the EV supply equipment at side B (see 3.7.129) more than the rated continuous current of the EV supply equipment at side B of the side B cable assembly based on agreement between side B cable assembly manufacturer and the EV supply equipment manufacturer, as long as the temperature requirement of the side B cable assembly according to 101.2.2.1 is fulfilled for the condition required by the EV supply equipment manufacturer. The rated boost current of the EV supply equipment at side B shall only be applied to side B cable assemblies according to IEC TS 62196-3-1.

The temperature controlled energy transfer and the rated continuous current of the EV supply equipment at side B shall be mutually agreed between the EV supply equipment manufacturer and the side B cable assembly manufacturer.

Requirements for side B cable assembly supporting a rated boost current of the EV supply equipment at side B according to IEC TS 62196-3-1 are under consideration.

*Compliance is checked by inspection and test in 101.2.4.2.*

## **102 Test methods**

### **102.1 Technical data**

The following information from the EV supply equipment manufacturer shall be provided for compliance test:

- operating points (102.2.5);
- operating temperature range;
- operating humidity range;
- supply network voltages (rated minimum voltage of the supply network at side A, rated maximum voltage of the supply network at side A).
- In addition to the above, the following information shall be provided for system C: additional operating points with a maximum ripple at side B, if any.

### **102.2 General test conditions**

#### **102.2.1 Ambient test conditions**

##### **102.2.1.1 Environmental conditions**

Unless otherwise specified, all tests shall be carried out under the following test conditions:

- temperature:  $(25 \pm 10)$  °C;
- atmospheric pressure: 86 kPa to 106 kPa;
- relative humidity: 10 % to 90 % (without condensation).

##### **102.2.1.2 Test power requirements**

Power to the DUT shall be according to IEC 60038, if designed to be supplied by the supply network.

- AC power frequency: 50 Hz  $\pm$  0,5 Hz; 60 Hz  $\pm$  0,5 Hz.
- AC power voltage, for example: 100/200 V; 120/240 V; 240/415 V, 230/400 V  $\pm$  10 %; 220/380 V  $\pm$  10 %.
- degree of voltage unbalance on AC power: < 5 %.
- AC power waveform: sinusoidal, with a distortion factor less than
  - for system A and system C: 8 %, and
  - for system B: 5 %.

### **102.2.2 Measuring instruments**

The characteristics of the measuring equipment shall be suitable to verify the specified values in the corresponding test items.

The equipment for measurement of voltage, current, temperature and time shall be according to suitable requirements for calibration and to IEC Guide 115.

NOTE Guidance about good practices for calibration can be found in ISO/IEC 17025.

For system B, the following requirements also apply: the instruments used shall enable the values of voltage and current to be measured. The calibre of these instruments and measuring methods shall be chosen so as to ensure the accuracy specified for each test. For analogue instrument, this implies that readings shall be taken in the last third of the graduated scale. Any other measuring instruments may be used provided they give an equivalent accuracy.

### **102.2.3 Test setups**

The general test setup for system A is shown in Figure 129.

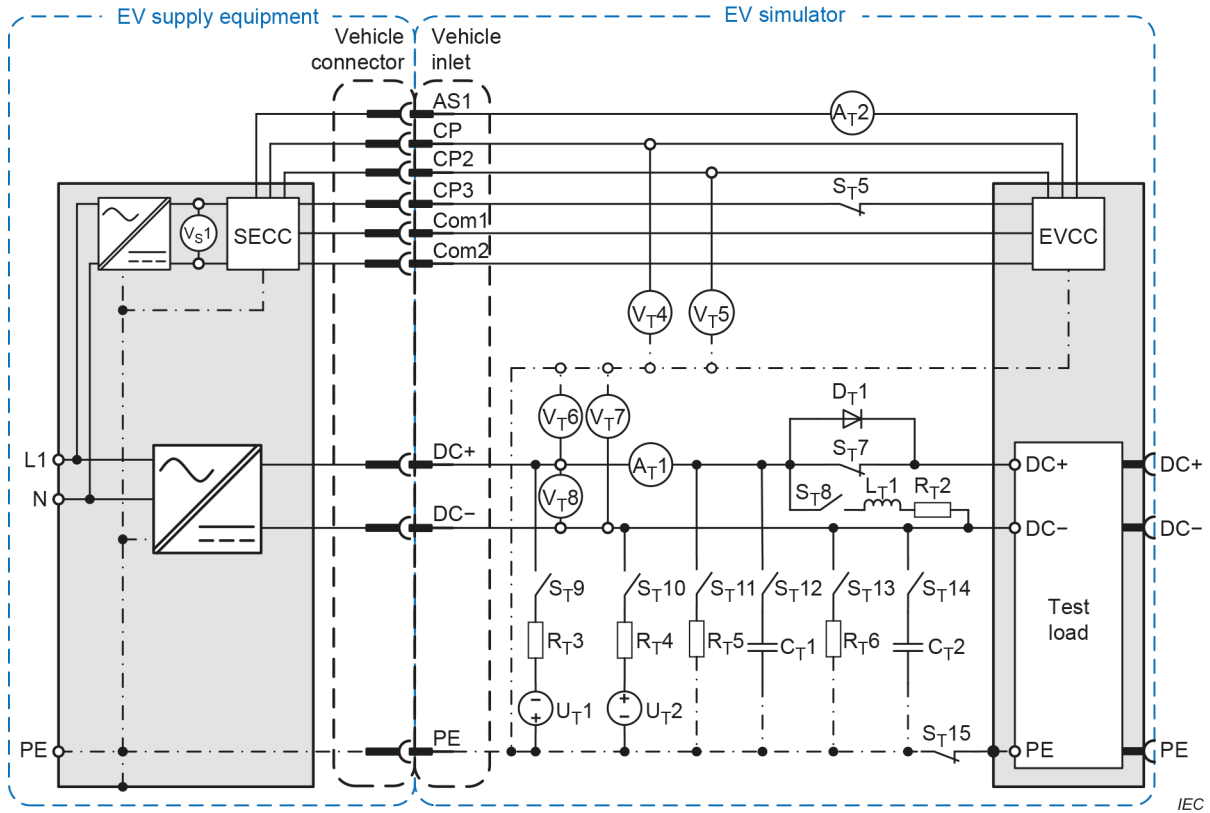

**Key**

L1, N	AC or DC supply network	$D_T$	diode in the test setup
PE	protective conductor contact	$S_T$	switch or relay in the test setup
CP, CP2, CP3	control pilot conductor contacts of system A	$C_T$	capacitor in the test setup
Com1, Com2	digital communication conductor contacts	$V_T$	voltmeter in the test setup
DC+	positive terminal of side B	$R_T$	resistor in the test setup
DC-	negative terminal of side B	$L_T$	inductor in the test setup
SECC	supply equipment communication controller	$U_T$	voltage source in the test setup
EVCC	electric vehicle communication controller	$V_s$	voltmeter in the EV supply equipment
Test load	test load according to 102.2.4 unless otherwise specified (see Figure 132)	$A_T$	ammeter in the test setup

**Figure 129 – General test setup for system A**

The general test setup for system B is shown in Figure 130.

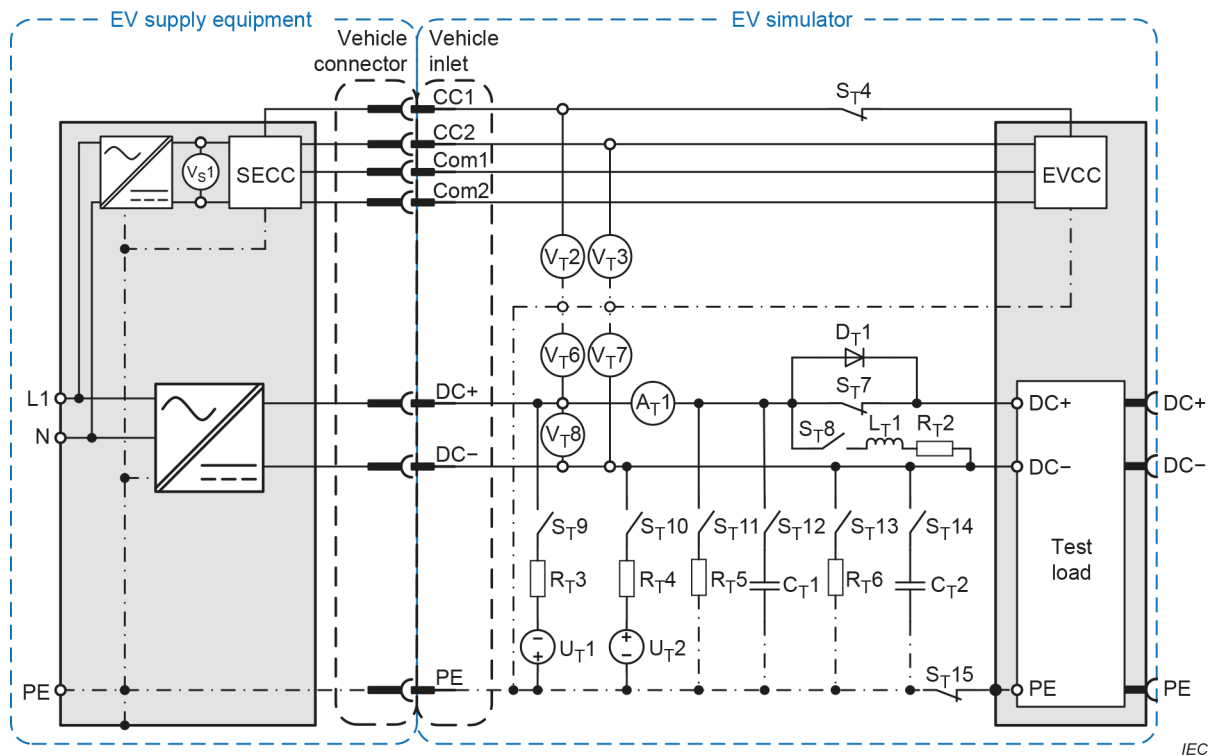
**Key**

L1, N	AC or DC supply network	$D_T$	diode in the test setup
PE	protective conductor contact	$S_T$	switch or relay in the test setup
CC1, CC2	control pilot conductor contacts of system B	$C_T$	capacitor in the test setup
Com1, Com2	digital communication conductor contacts	$V_T$	voltmeter in the test setup
DC+	positive terminal of side B	$R_T$	resistor in the test setup
DC-	negative terminal of side B	$L_T$	inductor in the test setup
SECC	supply equipment communication controller	$U_T$	voltage source in the test setup
EVCC	electric vehicle communication controller	$V_S$	voltmeter in the EV supply equipment
Test load	test load according to 102.2.4 unless otherwise specified (see Figure 132)	$A_T$	ammeter in the test setup

**Figure 130 – General test setup for system B**

The general test setup for system C is shown in Figure 131.

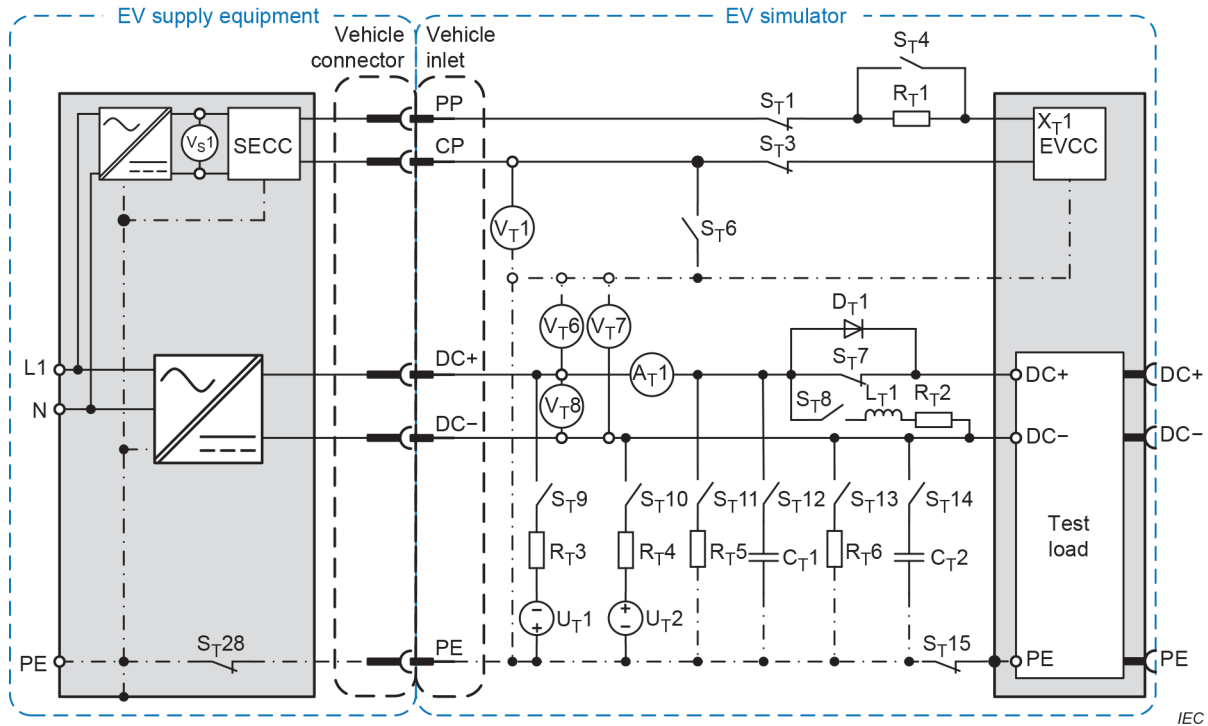

IEC

**Key**

L1, N	AC or DC supply network	D <sub>T</sub>	diode in the test setup
PE	protective conductor contact	S <sub>T</sub>	switch or relay in the test setup
PP	proximity pilot conductor contact	C <sub>T</sub>	capacitor in the test setup
CP	control pilot conductor contact of system C	V <sub>T</sub>	voltmeter in the test setup
DC+	positive terminal of side B	R <sub>T</sub>	resistor in the test setup
DC-	negative terminal of side B	L <sub>T</sub>	inductor in the test setup
SECC	supply equipment communication controller	U <sub>T</sub>	voltage source in the test setup
EVCC	electric vehicle communication controller	V <sub>S</sub>	voltmeter in the EV supply equipment
Test load	test load according to 102.2.4 unless otherwise specified (see Figure 132)	X <sub>T</sub>	voltage source for the proximity pilot circuit
A <sub>T</sub>	ammeter in the test setup		

**Figure 131 – General test setup for system C**

**102.2.4 Test load**

The test load shown in Figure 132 specifies an example of a simplified equivalent circuit diagram of the EV used for energy transfer. This simplified equivalent circuit diagram is used for specific test conditions relevant to the test cases specified in this document.

A test load such as a resistive load, an electronic load or a voltage source (for example, a battery system) shall be used. An electronic load operating under constant resistance is not considered as a resistive load. The test load is part of an EV simulator, required to establish basic signalling and/or digital communication with the EV supply equipment.

Unless otherwise specified, a resistive load or an electronic load shall be used for the compliance tests.

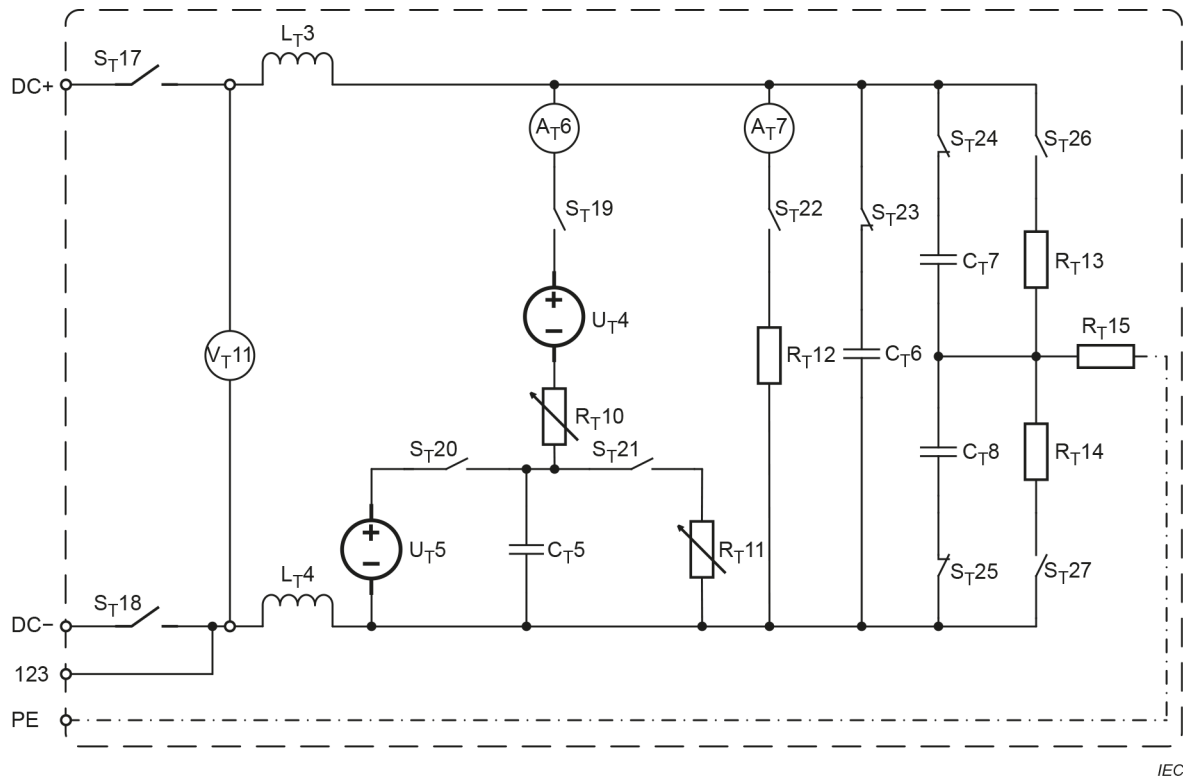

IEC

**Key**

$S_{T17}, S_{T18}$	test load disconnection device	PE	protective conductor
$C_{T5}$	capacitor for emulating the battery system	$U_{T4}$	ideal voltage source
$C_{T6}$	X-capacitor	$U_{T5}$	electronic load/controlled voltage source
$C_{T7}, C_{T8}$	Y-capacitor	$R_{T10}, R_{T11}$	variable resistor to set operating voltage point
$V_{T11}$	side B voltage of EV supply equipment (test load side)	$R_{T12}$	resistor for emulating auxiliary load
$A_{T6}$	emulated current to the battery system	$R_{T15}$	resistor for emulating the voltage surge between DC+ and DC-, and between DC+/DC- and PE
$A_{T7}$	emulated current to the auxiliary load	123	contact after the DC- disconnection device
$S_T$	switch, contactor or relay	$L_{T3}, L_{T4}$	inductance of the test load, including cabling. The total inductance is $L_T = L_{T3} + L_{T4}$ .
$R_{T13}, R_{T14}$	resistor for emulating asymmetric loads	DC+, DC-	side B terminals

**Figure 132 – Test load example**

Recommended circuit parameters of the test load for each system are shown in Table 120. The test load impedance shall comply with the requirements in Annex EE.

**Table 120 – Recommended circuit parameters of the test load**

Symbol	System A	System B	System C
$L_{T3} + L_{T4}$	1 $\mu$ H to 3 $\mu$ H	1 $\mu$ H to 3 $\mu$ H	1 $\mu$ H to 3 $\mu$ H
$C_{T5}$	5 600 $\mu$ F	5 600 $\mu$ F	5 600 $\mu$ F
$C_{T6}$	Not used	Not used	470 $\mu$ F
$C_{T7}, C_{T8}$	4,7 nF	2 $\mu$ F	2 $\mu$ F
$S_{T17}, S_{T18}$	As specified in respective test		
$S_{T19}$	As specified in respective test		
$S_{T20}$	Open or closed (as specified in respective test)	Open	Open
$S_{T21}$	Open or closed (as specified in respective test)	Closed	Closed
$S_{T22}$	Open	Open	As specified in respective test
$S_{T23}, S_{T24}, S_{T25}, S_{T26}, S_{T27}$	As specified in respective test		
$R_{T10}$	Variable (10 m $\Omega$ to 2 000 m $\Omega$ )	Variable (20 m $\Omega$ to 200 m $\Omega$ )	Variable (50 m $\Omega$ to 100 m $\Omega$ )
$R_{T11}$	Variable (set by the required voltage operating point)	Variable (0,1 m $\Omega$ to 2 m $\Omega$ )	Variable (0,1 m $\Omega$ to 2 m $\Omega$ )
$R_{T12}$	Not used	Not used	10 $\Omega$ (< 500 V) 50 $\Omega$ (500 V to 1 000 V)
$R_{T13}, R_{T14}$	Not used	Not used	As specified in respective test
$R_{T15}$	50 $\Omega$	0 $\Omega$	0 $\Omega$
$U_{T4}$	Not used	0 V to 950 V	0 V to 1 000 V
$U_{T5}$	0 V to 1 000 V	Not used	Not used

### 102.2.5 Operating points for tests

Figure 133 shows the range of present voltage and present current at side B of the EV supply equipment, as well as specific operating points OP1 to OP7. These operating points are used as test points in some tests.

If the EV supply equipment shows any discontinuous behaviour in its operating range, for example, in case of cascaded architecture of PECs, it might be necessary to add additional test points.

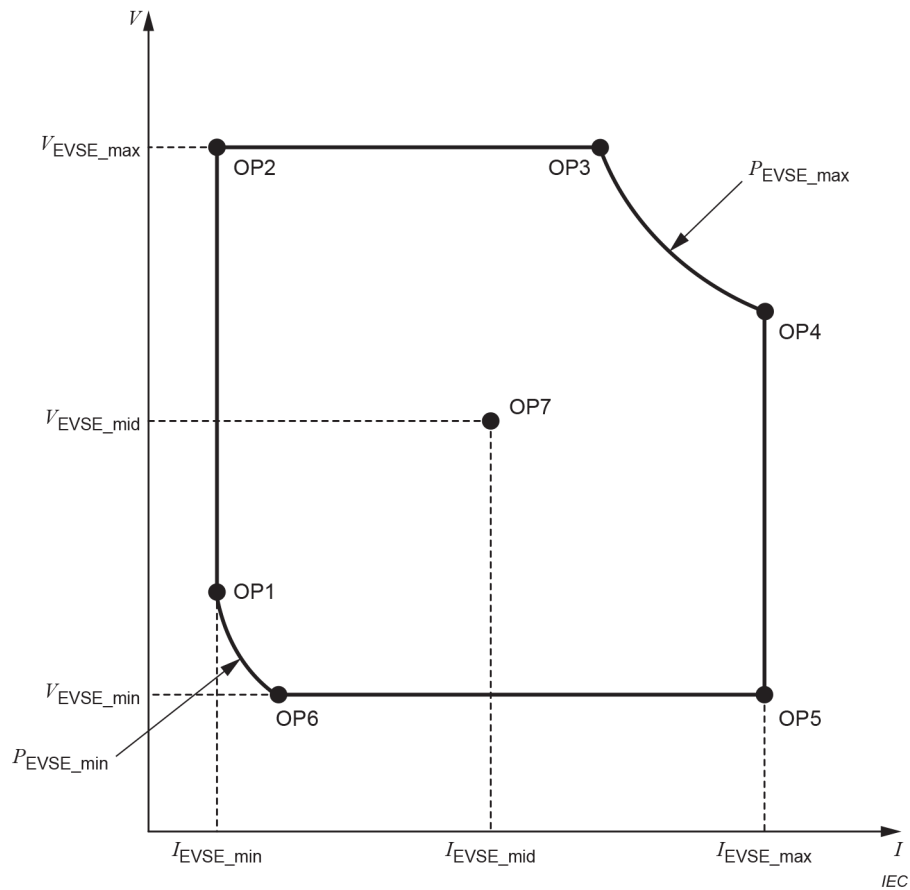
**Key**

$I_{EVSE\_max}$	maximum operating current of EV supply equipment	OP1	$V_{EVSE\_min}$ and $P_{EVSE\_min}$
$I_{EVSE\_mid}$	$(I_{EVSE\_max} + I_{EVSE\_min}) / 2$	OP2	$V_{EVSE\_max}$ and $I_{EVSE\_min}$
$I_{EVSE\_min}$	minimum operating current of EV supply equipment	OP3	$V_{EVSE\_max}$ and $P_{EVSE\_max}$
$V_{EVSE\_max}$	maximum operating voltage of EV supply equipment	OP4	$I_{EVSE\_max}$ and $P_{EVSE\_max}$
$V_{EVSE\_mid}$	$(V_{EVSE\_max} + V_{EVSE\_min}) / 2$	OP5	$V_{EVSE\_min}$ and $I_{EVSE\_max}$
$V_{EVSE\_min}$	minimum operating voltage of EV supply equipment	OP6	$V_{EVSE\_mid}$ and $P_{EVSE\_mid}$
OP	operating point	OP7	$V_{EVSE\_mid}$ and $I_{EVSE\_mid}$
OP <sub>n</sub>	voltage and current depending on test conditions		

**Figure 133 – Operating points**

## **Annexes**

The annexes of IEC 61851-1:2017 apply.

*Additional annexes:*

## **Annex AA** (normative)

### **EV supply equipment of system A**

#### **AA.1 General**

Annex AA provides the specific requirements for the EV supply equipment of system A, in addition to the general requirements as defined in the body text of this document.

System A is a regulated EV supply equipment using a dedicated CAN communication circuit for digital communication between an EV supply equipment and an EV to control energy transfer. The vehicle coupler of configuration AA as specified in IEC 62196-3 or IEC TS 62196-3-1 is applicable to system A. The specific requirements for digital communication and details of the communication actions and parameters of system A are defined in IEC 61851-24:2023, Annex A.

NOTE For system A EV supply equipment with automated connection device, see IEC 61851-23-1.

The rated maximum voltage of a system A EV supply equipment at side B is  $\leq 1\,000$  V DC.

This system is suitable for the passenger vehicles and light trucks.

Annex AA defines the system with an AC side A, but does not prohibit a DC side A. Annex AA includes information on the circuits on the EV.

Annex AA is also applicable to the system A BPT EV supply equipment. Unless otherwise specified, the requirements for a system A EV supply equipment in this document are also applicable to the BPT EV supply equipment. For general information regarding BPT, refer to Annex DD.

More detailed information on system A is defined in IEEE Std 2030.1.1™.

#### **AA.2 Circuit diagram**

The system A EV supply equipment circuit diagram is shown in Figure AA.1, including the circuit diagram between the EV supply equipment and the EV for energy transfer control. A CAN-bus circuit is provided for digital communication with the EV. The definition and description of symbols and terms in Figure AA.1 are given in Table AA.1. The values of the parameters for the circuit diagram are given in Table AA.2.

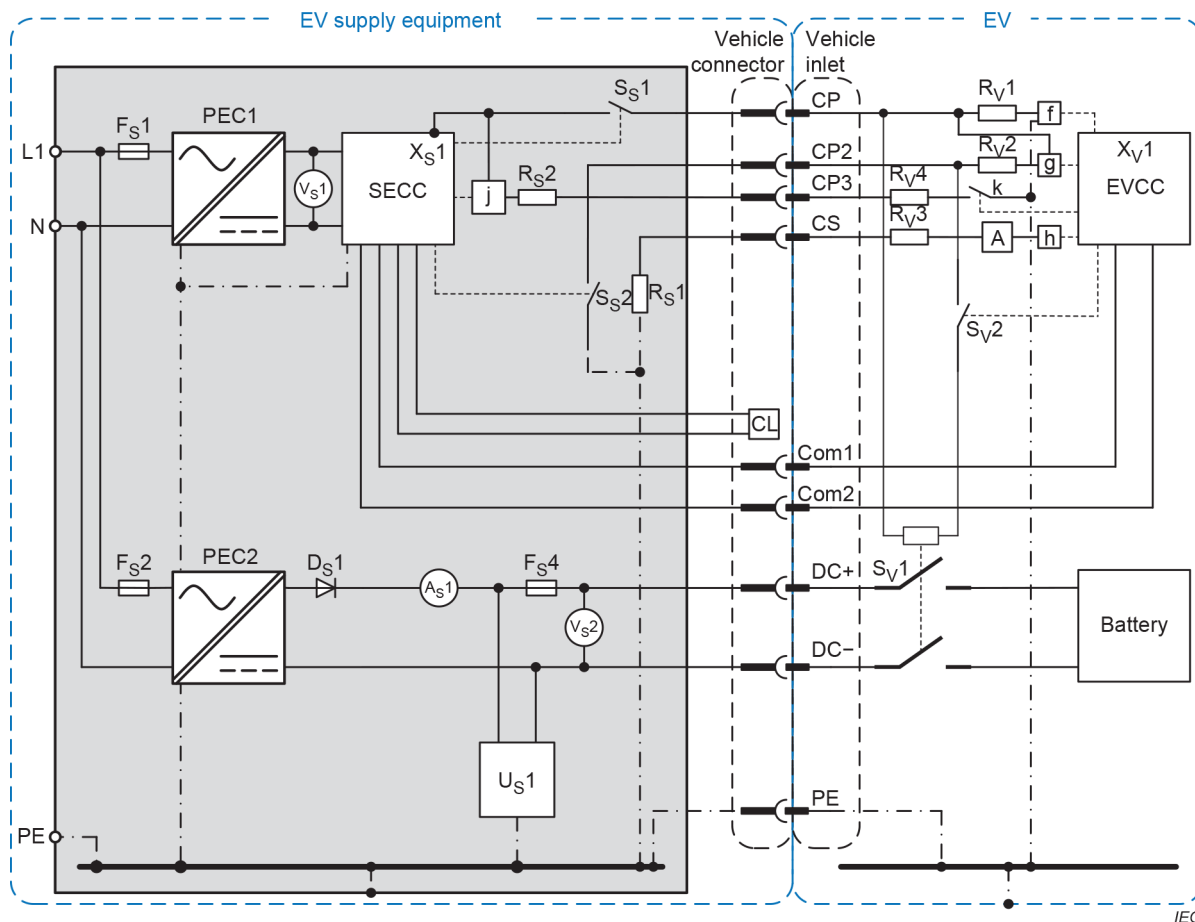

IEC

**Key**

L1, N	AC or DC supply network	D <sub>S1</sub>	diode in the EV supply equipment
PE	protective conductor contact	S <sub>S</sub>	switch or relay in the EV supply equipment
CP, CP2, CP3, CS	control pilot conductor contacts of system A	S <sub>V, k</sub>	switch or relay in the EV
Com1, Com2	digital communication conductor contacts	A <sub>S</sub>	ammeter in the EV supply equipment
DC+	positive terminal of the side B	R <sub>S</sub>	resistor in the EV supply equipment
DC-	negative terminal of the side B	R <sub>V</sub>	resistor in the EV
SECC	supply equipment communication controller	U <sub>S</sub>	earth leakage current measurement device
EVCC	electric vehicle communication controller	V <sub>S</sub>	voltmeter in the EV supply equipment
PEC	power electronic converter	F <sub>S</sub>	over-current protection device
f, g, h, j	optocoupler	A	unintentional current flow prevention circuit
X <sub>V</sub>	voltage source in the EV	CL	vehicle connector lock and latch monitoring circuit
X <sub>S</sub>	voltage source in the EV supply equipment		

NOTE The unintentional current flow prevention circuit (A), operated by the EV, connects or disconnects the pilot wire (CS) and the EVCC. During the energy transfer sequence between a) the closure of switch k (after handshaking) and b) the opening of the EV disconnection device S<sub>V1</sub> (after energy transfer), this circuit disconnects the EVCC from (CS). See Figure AA.4 for the energy transfer flow diagrams.

**Figure AA.1 – Overall circuit diagram of system A EV supply equipment and EV**

**Table AA.1 – Definition of symbols of the overall circuit diagram of a system A EV supply equipment**

	Symbols	Definitions	Requirements
System A EV supply equipment	D <sub>S</sub> 1	Reverse-current-prevention device (for example, diode: cathode on the EV side, anode on the EV supply equipment side)	AA.3.9
	S <sub>S</sub> 1	Switch on CP for controlling the energy transfer start/stop signals from the EV supply equipment to the EV	Table AA.2, AA.3.7, Clause AA.4
	S <sub>S</sub> 2	Switch on CP for controlling the energy transfer start/stop signals from the EV supply equipment to the EV	Table AA.2, AA.3.7, Clause AA.4
	j	Signal sensing device to detect if the EV is ready/not ready for energy transfer	Clause AA.4
	V <sub>S</sub> 2	Voltage measurement device	AA.3.3, AA.4.4
	A <sub>S</sub> 1	Current measurement device	AA.4.4
	F <sub>S</sub> 1, F <sub>S</sub> 2, F <sub>S</sub> 3, F <sub>S</sub> 4	Short-circuit protection device (for example, current limiting fuse) In case the vehicle connector has the short-circuit protection device, the EV supply equipment is permitted to not have one.	AA.3.5
	R <sub>S</sub> 1	Resistor	Table AA.2
	R <sub>S</sub> 2	Resistor	Table AA.2
	X <sub>S</sub> 1	DC power supply for the EV disconnection device	Table AA.2, AA.3.12
EV	S <sub>V</sub> 1	EV disconnection device (DC+/DC–)	AA.3.7, AA.3.8, AA.3.15, Clause AA.4
	S <sub>V</sub> 2	Relay for turning on the EV disconnection device	Clause AA.4
	f	Signal sensing device to detect the status of S <sub>S</sub> 1	Clause AA.4
	g	Signal sensing device to detect the status of S <sub>S</sub> 2	Clause AA.4
	h	Signal sensing device to detect mating/un-mating of the vehicle coupler	Clause AA.4
	k	Switch to give the go ahead/stop to transfer energy	Clause AA.4
	R <sub>V</sub> 3	Resistor	Table AA.2
	R <sub>V</sub> 4	Resistor	Table AA.2
X <sub>V</sub> 1	DC power supply in the EV	Table AA.2	
Terminal and wire	DC+	Positive terminal of side B	AA.3.15
	DC–	Negative terminal of side B	AA.3.15
	CP	Control pilot which indicates the start/stop status of EV supply equipment	Table AA.2
	CP2	Control pilot which indicates the start/stop status of EV supply equipment	Table AA.2
	CS	Pilot wire which indicates the status of the vehicle coupler connection	Table AA.2, AA.3.14
	CP3	Control pilot which confirms that the EV is ready for energy transfer	Table AA.2, AA.3.2, AA.3.8.2
	Com1 Com2	Digital communication conductors	AA.3.2, Clause AA.4, IEC 61851- 24:2023, Annex A
	PE	Protective conductor between the EV supply equipment and EV for detecting the first fault between DC+/DC– and the protective conductor	AA.3.1.1, AA.3.8.2
	A <sub>S</sub> 1	Auxiliary power supply from the EV (in-connector terminal)	Table AA.2, AA.6.3.6
Vehicle connector	CL	Connector latching and latching mechanism	AA.3.3, AA.3.6

**Table AA.2 – Parameters and values of the circuit diagram for a system A EV supply equipment**

System A EV supply equipment					
Terminal/wire	Parameters	Minimum value	Typical value	Maximum value	Unit
CP	$X_S1$	10,8	12,0	13,2	V DC
CS	Resistor $R_S1$	190	200	210	$\Omega$
CP3	Resistor $R_S2$	950	1 000	1 050	$\Omega$
CP	Load current of switch $S_S1$	2		2 000	mA DC
CP2	Load current of switch $S_S2$	2		2 000	mA DC
$A_S1$	Voltage		12	16	V DC
	Current			6,4	A DC
EV					
CP	Load current (when $S_S1$ and $S_S2$ are closed)	10		2 000	mA DC
CP2	Load current (when $S_S1$ and $S_S2$ are closed)	10		2 000	mA DC
CS	Resistor $R_V3$	950	1 000	1 050	$\Omega$
	$X_V1$	8	12	16	V
CP3	Resistor $R_V4$	190	200	210	$\Omega$
$A_S1$	Voltage		12	16	V DC
	Current			6,4	A DC
	Rated fuse			10	A DC
	Voltage		12	16	V DC
NOTE Voltage of $A_S1$ is different from $X_S1$ .					

For a BPT application, resistance of  $A_S1$ , and protective conductor, each resistance shall be less than the line resistance equivalent to the one on the conditions of conductor temperature 80 °C, 1,25 mm<sup>2</sup> and 7,5 m (15 m for round-trip).

### AA.3 Specific safety requirements

#### AA.3.1 Fault protection in side B

##### AA.3.1.1 General

For fault protection in side B, the system A EV supply equipment shall have the following measures:

- a) protective separation between side A and side B according to 8.105.5;

NOTE This includes the isolating transformer and all associated circuits of side B.

- b) earth leakage current measurement using a grounding resistor between the side B live parts (DC+/DC-) and the protective conductor (enclosure and vehicle chassis);
- c) automatic disconnection of supply to side B at the first fault detected by the earth leakage current monitoring device;
- d) side B cable assembly consisting of line conductors that are individually insulated.

When the protective conductor forms part of a side B cable assembly, the cross-sectional area of the protective conductor shall be determined by the formula in IEC 60364-5-54:2011, 543.1.2. The minimum cross-sectional area of the protective conductor of the side B cable assembly shall be 0,75 mm<sup>2</sup>.

Table AA.3 shows the principle of fault protection. System A EV supply equipment shall comply with case 1.

**Table AA.3 – Principle of fault protection**

	<b>Power supply to EV in case of the first fault</b>	<b>Protection measure in case of the first fault</b>	<b>Protection against the secondary fault</b>
Case 1	Not allowed	Automatic error/emergency shutdown	Prohibition of operation at the first fault
Case 2	Allowed	Detection and notice of the first fault using an IMD  Recommendation for elimination of the first fault with the shortest practicable delay	PE equivalent to TN ground required  Visible warning for system operator at the detection of symmetric fault

The requirements in AA.3.1 also apply to the BPT EV supply equipment.

#### **AA.3.1.2 Automatic disconnection and earth leakage current monitoring**

System A EV supply equipment shall measure the earth leakage current between side B and its enclosure, or between side B and the vehicle chassis.

The EV supply equipment shall detect the first fault between side B live parts (DC+/DC–) and the protective conductor before and during energy transfer in 1 s or less, and then shall perform an error shutdown.

The procedure of this fault detection before energy transfer is provided in AA.4.3.3.

Specific requirements on the timing criteria for the error shutdowns are given in Table AA.5.

Fault current detection principle and performance requirements are defined in Figure AA.2 and Table AA.4.

If the insulation resistance cannot be determined, the EV supply equipment shall trigger and perform an error shutdown.

**NOTE** This can happen from internal failure or external factors, for example, if the capacitance in the EV is more than the expected value as defined in ISO 17409:2020.

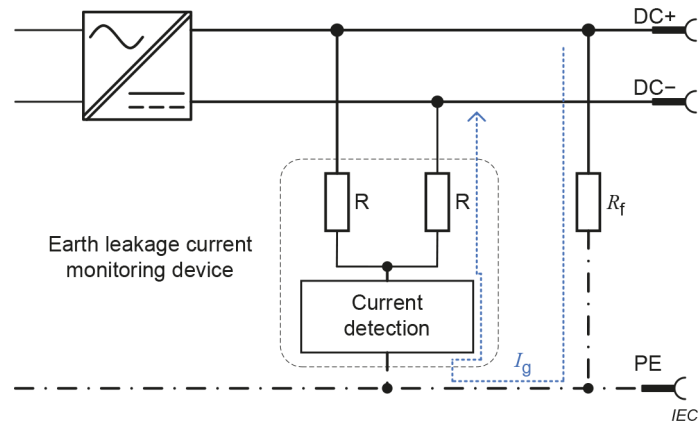

**Key**

- DC+, DC- side B live parts
- $R_f$  insulation resistance between side B live parts (DC+/DC-) and EV or enclosure at the first fault
- R grounding resistor to detect and limit the first fault current
- $I_g$  earth leakage current at the first fault between side B live parts (DC+/DC-) and the protective conductor

**Figure AA.2 – Failure detection principle by detection of DC leakage current**

**Table AA.4 – Requirements for earth leakage current fault monitoring**

Item	Detection performance
Maximum detection time <sup>a</sup>	Less than 1 s
Nuisance trip prevention	Minimum response time shall be more than 0,2 s with continuous threshold monitoring
Sensitivity <sup>b</sup>	Sensitivity of earth leakage current measuring device and grounding resistor of "R" shall be designed so that the body current of human at the first fault between side B live parts (DC+/DC-) and the protective conductor is within DC-2 zone in IEC 60479-1:2018, Figure 22.
<p><sup>a</sup> The detection time does not include shutdown time of the present current at side B.</p> <p><sup>b</sup> The actual body current may differ from the measured leakage current <math>I_g</math>, which should be taken into account when designing the EV supply equipment.</p> <p>EXAMPLE</p> <p>Set-up condition 1: When the current through the human body <math>I_h</math> is more than the DC-2 zone calculated by Formula (AA.1), a measurement device is designed to detect the deterioration of insulation resistance <math>R_f</math> as the first fault between side B live parts (DC+/DC-) and the protective conductor by measuring earth leakage current shown in Formula (AA.2).</p> $I_h = \frac{V_s^2}{\frac{R \cdot R_f}{R + R_f}} \quad (\text{AA.1})$ <p>where</p> <p><math>I_h</math> is the current through the human body;</p> <p><math>V_s^2</math> is the present voltage at side B between DC+ and DC-;</p> <p><math>R</math> is a grounding resistor;</p> <p><math>R_f</math> is an insulation resistance.</p> $I_g = \frac{V_s^2}{R + 2 \cdot R_f} \quad (\text{AA.2})$ <p>where</p> <p><math>I_g</math> is the measuring current;</p> <p><math>V_s^2</math> is present voltage at side B between DC+ and DC-;</p> <p><math>R</math> is a grounding resistor;</p> <p><math>R_f</math> is an insulation resistance.</p> <p>Set-up condition 2: The measurement device is designed to detect the current through the human body within DC-2 zone, except the set-up condition 1.</p>	

*Compliance is checked by the following test.*

- 1) *Connect the EV supply equipment to a test load with a dedicated EV simulator for the system under test. See Figure 129.*
- 2) *Start energy transfer with the procedure specified by the EV supply equipment manufacturer.*
- 3) *The EV supply equipment is operating at OP4.*

- 4) *Simulate the fault by closing  $S_{T11}$ .*
- 5) *Check that the EV supply equipment triggers error shutdown in 1 s or less after step 4).*
- 6) *Check that  $V_{S1}$  is not interrupted until the communication session is completed and the vehicle coupler is safely unlatched. See 6.3.1.108.*
- 7) *Repeat the test using  $S_{T13}$  in step 4).*

*The earth-fault resistance  $R_{T5}/R_{T6}$  should be adjusted so that the EV supply equipment detects the earth fault when the total insulation resistance  $R_f$  (Figure AA.2) between side B live parts (DC+/DC-) and PE (including  $R_{T5}/R_{T6}$  – See Figure 129) is  $\leq 100 \Omega/V$ , based on the rated maximum voltage of the EV supply equipment at side B ( $V_{T8}$ ) and the grounding resistor  $R$  (Figure AA.2).*

### **AA.3.1.3 Functionality of the earth leakage current monitoring device**

The integrity of the earth leakage current monitoring device shall be checked in the period from  $S_{S1}$  = closed to  $S_{S2}$  = closed. See Figure AA.3 and Figure AA.4.

The EV supply equipment shall not proceed with the communication session if an abnormality is detected on the earth leakage current monitoring device by this check.

The EV supply equipment shall check one of the following items for the diagnosis:

- a) loss of electrical continuity and short-circuit failure of the grounding resistance  $R$ ;
- b) loss of electrical continuity in the current detection circuit;
- c) loss of electrical continuity between the side B circuit and the earth leakage current monitoring device;
- d) loss of electrical continuity of the protective conductor.

### **AA.3.2 De-energization of the power supply to the EV**

*Compliance to 6.3.1.5 shall be checked according to the following tests.*

*Test 1:*

- 1) *Connect the EV supply equipment to a test load with a dedicated EV simulator for the system under test. See Figure 129.*
- 2) *Start energy transfer with the procedure specified by the EV supply equipment manufacturer.*
- 3) *Stop the digital communication from the EV simulator.*
- 4) *Check that the EV supply equipment triggers an error shutdown in 1 s or less after step 3).*

*Test 2:*

- 1) *Connect the EV supply equipment to a test load with a dedicated EV simulator for the system under test. See Figure 129.*
- 2) *Start energy transfer with the procedure specified by the EV supply equipment manufacturer.*
- 3) *Open  $S_{T5}$ .*
- 4) *Check that the EV supply equipment triggers an emergency shutdown after step 3).*

NOTE The compliance can also be checked according to the test specified by the EV supply equipment manufacturer.

### AA.3.3 Voltage measurement of side B live parts (DC+/DC–) for vehicle connector unlatch

According to 6.3.1.103, the vehicle connector shall not be unlatched when hazardous voltage is detected. To unlatch the vehicle connector, the present voltage at side B between DC+ and DC– shall be measured at  $V_{S2}$  in Figure AA.1, and be confirmed to be  $\leq 30$  V DC.

*Compliance checks a) and b) in 6.3.1.103 shall be tested by the following procedure.*

- 1) *Connect the EV supply equipment to a test load with a dedicated EV simulator for the system under test. See Figure 129. The setup of the test load in Figure 132 is in Table 120.*
- 2) *Start energy transfer with the procedure specified by the EV supply equipment manufacturer.*
- 3) *Confirm that the vehicle connector is latched on a vehicle inlet before insulation resistance check.*
- 4) *After the insulation resistance check, close  $S_{T17}$  and  $S_{T18}$ .*
- 5) *Stop energy transfer with the procedure specified by the EV supply equipment manufacturer.*
- 6) *In case of the normal condition test, open  $S_{T17}$  and  $S_{T18}$ . In case of the abnormal condition test, keep  $S_{T17}$  and  $S_{T18}$  closed and apply  $U_{T5}$  ( $S_{T20}$ : closed,  $S_{T21}$ : open) to  $C_{T5}$  so that  $V_{T8}$  is  $> 30$  V DC.*
- 7) *Confirm that the vehicle connector remains latched on a vehicle inlet while  $V_{T8}$  is  $> 30$  V DC.*

### AA.3.4 Overcurrent protection of side B

The EV supply equipment shall provide an overcurrent protection to protect the side B of the EV supply equipment and the EV. If the following condition is continuously fulfilled for a duration of 5 s, the EV supply equipment shall trigger an error shutdown:

- at a present current at side B  $\geq 50$  A DC: the present current at side B is more than 120 % of the target current of the EV;
- at a present current at side B  $< 50$  A DC: the present current at side B is more than the target current of the EV by 10 A DC or more.

*Compliance is checked by design review to verify that a function is provided.*

A circuit diagram indicating that the EVCC is separated from side A and from side B shall be provided by the EV supply equipment manufacturer.

### AA.3.5 Short-circuit protection of side B

Short-circuit protection means, such as a current-limiting fuse, shall be provided in side B of the system A EV supply equipment in order to protect the circuits of the EV supply equipment and the EV from short-circuit.

The short-circuit protection device shall meet the following requirements:

- quick-break type;
- normal melting rating:  $\leq 400\,000$  A<sup>2</sup>s.

The vehicle connector and the cross-sectional area of the DC+ and DC– conductors of the side B cable assembly shall have a  $I^2t \geq 6\,400\,000$  A<sup>2</sup>s.

The DC+ and DC– conductors of the side B cable assembly shall each have the cross-sectional area of  $\geq 22$  mm<sup>2</sup>.

When the vehicle connector is equipped with short-circuit protection means, the  $I^2t$  of the side B cable assembly may be reduced.

NOTE 1 A battery system short-circuit, by reverse connection of the cable, causes a very high short-circuit current.

NOTE 2 The system A EV provides short-circuit protection device, which protects the side B cable assembly with  $I^2t$  of 2 500 000 A<sup>2</sup>s. See ISO 17409.

*Compliance is checked by inspection.*

**AA.3.6 Latch monitoring for the vehicle connector**

**AA.3.6.1 General**

The vehicle connector shall have a means of mechanical latching, electrical latching, and latch monitoring.

The vehicle connector shall also have a means to provide system A EV supply equipment with information on anomaly detection in monitoring of latch and electrical latching. Figure AA.3 shows an example of a detection means in the vehicle connector and system A EV supply equipment.

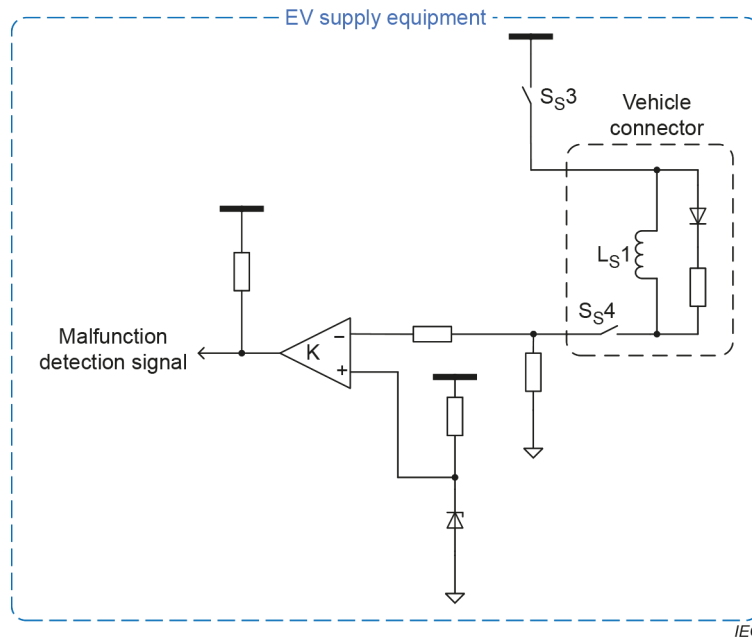

**Key**

K	comparator	S <sub>S</sub> 4	switch or relay, interlocked with latching
S <sub>S</sub> 3	switch or relay	L <sub>S</sub> 1	solenoid

**Figure AA.3 – Example of vehicle connector latch monitoring circuit**

**AA.3.6.2 Latch monitoring for vehicle connector not equipped with short-circuit protection**

Vehicle connectors not equipped with short-circuit protection means shall constantly monitor the state of the latch holding circuit during the communication session.

In case of failure of mechanical latching or electrical latching of the vehicle connector, the EV supply equipment shall not energize the side B live parts (DC+/DC–) connected to the vehicle connector. If a failure is detected during energy transfer, the EV supply equipment shall reduce the present current at side B to  $\leq 5$  A DC in 2 s or less. Then,  $S_{S1}$  shall be opened.

*Compliance is checked by the following test.*

- 1) A vehicle inlet shall be prepared with a modification in which the latch holder (hole) of the vehicle inlet is covered by a metal plate or an equivalent hard material that inhibits the latch holding of the vehicle connector. See Figure AA.4.

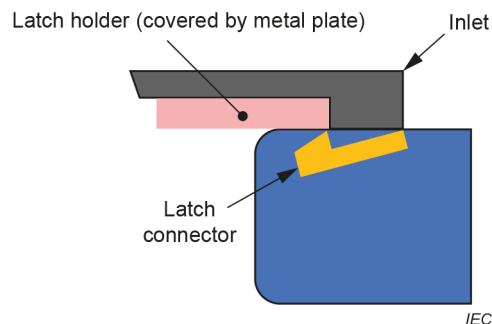

**Figure AA.4 – Example of vehicle inlet with the latch holder covered by a metal plate that inhibits latch holding**

- 2) Connect the EV supply equipment to a test load and a dedicated EV simulator. See Figure 129. The setup of the test load in Figure 132 is in Table 120.
- 3) Start energy transfer with the procedure specified by the EV supply equipment manufacturer.
- 4) Confirm that  $V_{T8}$  is  $\leq 60$  V DC and that the EV supply equipment triggers an error shutdown, displaying a relevant alarm or error information, if any.

#### **AA.3.6.3 Latch monitoring for vehicle connector equipped with short-circuit protection**

The vehicle connector equipped with short-circuit protection means shall have a latching device with a self-holding mechanism. When hazardous voltage is present at DC+/DC– of the vehicle connector, the vehicle connector shall be kept latched to the vehicle inlet if the latch holding circuit of the vehicle connector fails.

The vehicle connector which has the self-holding mechanism does not need to constantly monitor the state of, or detect an error in, the latch holding circuit during the communication session.

#### **AA.3.7 Protection of the EV disconnection device**

In order to prevent welding the EV disconnection device, switches  $S_{S1}$  and  $S_{S2}$  shall not open if the current is  $> 5$  A DC.

#### **AA.3.8 Fault conditions and criteria for transfer to error and emergency shutdown**

##### **AA.3.8.1 Error shutdown**

System A EV supply equipment shall perform an error shutdown according to 6.3.1.113.3.

Table AA.5 provides the shutdown times and criteria of error shutdown.

**Table AA.5 – Error shutdown times and criteria**

Fault	Response time of EV supply equipment to start shutdown	Present current at side B descending rate	Shutdown triggered by	General	Present voltage at side B descending rate	Condition to unlatch vehicle connector
Loss of digital communication <sup>a</sup> (6.3.1.5, AA.3.2)	1 s	$\Delta I_{out} > 200 \text{ A/s}$ DC	EV supply equipment	The EV supply equipment shall reduce side B to: – present current at side B $\leq 5 \text{ A DC}$ ; <sup>c</sup> – present voltage at side B $\leq 60 \text{ V DC}$ between DC+ and DC–, between DC+/DC– and the protective conductor. <sup>d</sup>	See AA.3.15	After shutdown process is completed and the present voltage at side B $\leq 30 \text{ V DC}$ . See Figure AA.3.
Overvoltage at the vehicle connector during 400 ms (6.3.1.106)	1,6 s					
Overvoltage between side B live parts (DC+/DC–) and protective conductor in case of single first fault (6.3.1.112.2)	5 s					
Over temperature of DC contact assemblies (101.2.3, 101.2.4.3, Clause AA.9)	9 s					
Thermal sensing fault (101.2.3.3)	9 s					
Earth leakage current fault between side B live parts (DC+/DC–) and protective conductor (AA.3.1)	1 s					
Over current of side B (AA.3.4)	5 s					
Malfunction of latch device (latch position) (AA.3.6.1, AA.3.6.2)	0,1 s					
Malfunction of latch device (latch holding circuit) (AA.3.6.1, AA.3.6.2)	0,1 s					
Error shutdown specified by the EV supply equipment manufacturer including earth fault on the AC primary circuit, and short-circuit on the AC primary circuit	Specified by the EV supply equipment manufacturer					
Under-voltage at the vehicle connector <sup>b</sup> (AA.6.3.7)	2 s					
Short-circuit of side B (13.3)	3 s	Specified by the EV supply equipment manufacturer. See AA.3.3.				

Fault	Response time of EV supply equipment to start shutdown	Present current at side B descending rate	Shutdown triggered by	General	Present voltage at side B descending rate	Condition to unlatch vehicle connector
EV requested error shutdown by sending: H'102.4.X = 1, or H'102.5.2 = 1, or switch k = OFF	1 s: CAN 0,1 s: switch k	$\Delta I_{out} > 200 \text{ A/s}$	EV			
<p>a Loss of digital communication means 1 s continuous disruption and no data frame of CAN communication.</p> <p>b Mandatory for BPT.</p> <p>c EV should disconnect side B between the EV supply equipment and EV by opening the EV disconnection device when the present current at side B <math>\leq 5 \text{ A DC}</math>.</p> <p>d Voltage at the vehicle connector. The EV supply equipment can reduce the present voltage at side B after the EV disconnection device is opened.</p>						

After detection of errors, the system A EV supply equipment shall send the messages to the EV by digital communication (refer to IEC 61851-24:2023, Table A.3).

Table AA.6 and Table AA.7 provide the message parameter exchanges and relevant actions of error shutdown.

**Table AA.6 – Action and message parameter for error shutdown triggered by the EV supply equipment**

Step	Action	Message parameter	Criterion
1	Fault detected	n.a	n.a
2	Start error shutdown process and notification to the EV	H'109.5.1 = 1, or H'109.5.4 = 1, and H'109.5.5 = 1	Send message parameters to the EV
3	Energy transfer current control	n.a	$\leq 3$ s and $\Delta A_S1 \geq -200$ A/s
4	Notification to the EV and move to step 6, when the EV supply equipment cannot allow welding detection by the EV	H'108.0.0 = 0, and H'109.5.0 = 1	Send message parameter to the EV when the present current at side B is $\leq 5$ A DC
5	Notification to the EV and move to Table AA.7, step 6, when the EV supply equipment can allow welding detection by the EV	H'108.0.0 = 1, and H'109.5.0 = 1	Send message parameter to the EV when the present current at side B is $\leq 5$ A DC
6	$S_S1, S_S2 =$ open	n.a	$\leq 1$ s from step 4
7	Voltage removal	n.a	$\leq 2$ s and $V_S2 \leq 30$ V DC from the end of the step 5
8	Unlatched or remain latched	n.a	Specified by the EV supply equipment manufacturer

**Table AA.7 – Action and message parameter for error shutdown triggered by the EV**

Step	EV			EV supply equipment		
	Action	Message parameter	Criterion	Action	Message parameter	Criterion
1	Fault detected	n.a	n.a	n.a	n.a	n.a
2	Request for error shutdown	H'102.4.X = 1, or H'102.5.2 = 1, or switch (k) = off	n.a	n.a	n.a	n.a
3	n.a	n.a	n.a	Start error shutdown process	H'109.5.5 = 1	Send message parameters to the EV
4	n.a	n.a	n.a	Energy transfer current control	n.a	$\leq 3$ s and $\Delta A_S1 \geq -200$ A/s
5	n.a	n.a	n.a	Notification to the EV	H'108.0.0 = 1 H'109.5.0 = 1	Send message parameters to the EV when the present current at side B is $\leq 5$ A DC

Step	EV			EV supply equipment		
	Action	Message parameter	Criterion	Action	Message parameter	Criterion
6	Welding detection	H'102.5.3 = 1	Welding detection time $\leq 4$ s  Send the message to the EV supply equipment after finishing welding detection	n.a	n.a	n.a
7	n.a	n.a	n.a	$S_{S1}, S_{S2} =$ open	n.a	$\leq 1$ s from step 6
8	n.a	n.a	n.a	Voltage removal	n.a	$\leq 2$ s and $V_{S2} \leq 30$ V DC  From the end of the step 7
9	n.a	n.a	n.a	Unlatched or remain latched	n.a	Specified by the EV supply equipment manufacturer

### AA.3.8.2 Emergency shutdown after control pilot disconnection

The system A EV supply equipment shall decrease the present current at side B to  $\leq 5$  A DC in 30 ms or less after the loss of electrical continuity (disconnection) of the control pilot CP3.

Table AA.8 and Table AA.9 provide the emergency shutdown times, actions and criteria.

**Table AA.8 – Emergency shutdown times and criteria**

Fault	Trigger of emergency shutdown	Response time of EV supply equipment to start emergency shutdown process	Maximum time to the present current at side B $\leq 5$ A DC from fault occurrence	Maximum time to reach safe voltage from fault occurrence
Loss of electrical continuity of protective conductor (6.3.1.2)  Disconnection of vehicle coupler during energy transfer (9.101, AA.4.3.5.3)	Loss of electrical continuity of the control pilot CP3	Immediately after the fault	$< 30$ ms	$< 1$ s  $\leq 60$ V DC between DC+ and DC-, between DC+/DC- and protective conductor

**Table AA.9 – Actions and criteria for emergency shutdown**

Step	Action	Criterion
1	Fault detected Loss of electrical continuity of the control pilot CP3	n.a
2	Reduction of the present current at side B	$\leq 5$ A DC in 30 ms or less from step 1
3	$\leq 60$ V DC between DC+ and DC–, between DC+/DC– and protective conductor	$\leq 1$ s from step 1

**AA.3.8.3 Emergency shutdown for short-circuit fault**

The system A EV supply equipment shall trigger an emergency shutdown when a short-circuit is detected at side B.

*Compliance is checked by the following test.*

- 1) Connect the EV supply equipment to a test load with a dedicated EV simulator for the system under test. See Figure 129. The setup of the test load in Figure 132 is in Table 120.
- 2) Start energy transfer with the procedure specified by the EV supply equipment manufacturer.
- 3) The EV supply equipment is operated at OP4.
- 4) Close  $S_{T8}$ . Use  $R_{T2} = 100$  m $\Omega$  and  $L_{T1} = 0$  mH.
- 5) Check that the EV supply equipment triggered an emergency shutdown.
- 6) Check that
  - a)  $A_{T1} \leq 5$  A DC in 30 ms or less after step 5), and
  - b)  $V_{T8} \leq 60$  V DC in 1 s or less after step 5).
- 7) Check that  $V_{S1}$  is not interrupted until the FPT sequence is completed and the vehicle coupler is safely unlatched. See 6.3.1.108.

**AA.3.9 Inrush current limitation by the EV supply equipment**

When the EV disconnection device is closed, the inrush current through the side B live parts (DC+/DC–) of system A EV supply equipment shall be  $< 20$  A DC at the vehicle connector.

The limitation of inrush current shall be achieved on the EV supply equipment by either

- reverse-current prevention device as defined in Figure AA.1 and Table AA.1, or
- pre-charge circuit as defined in Figure AA.11 and AA.6.3.4.

NOTE The EV is responsible for preventing the uncontrolled reverse power transfer (RPT) due to an EV failure, for example, the welding of EV disconnection device.

*Compliance is checked by the following test.*

- 1) Connect the EV supply equipment to a test load with a dedicated EV simulator for the system under test. See Figure 129. The setup of the test load in Figure 132 is in Table 120.
- 2) Charge  $C_{T5}$  to the rated maximum voltage of the EV supply equipment at side B by closing  $S_{T20}$  and adjusting  $U_{T5}$ .
- 3) Start a communication session with the procedure specified by the EV supply equipment manufacturer.

- 4) Close  $S_{T17}$  and  $S_{T18}$  after the EV supply equipment finished the insulation resistance check. See Figure AA.4.
- 5) Check that  $A_{T1} < 20$  A DC.

### AA.3.10 Regulation of the present current at side B in CCM

The deviation of the present current at side B from the target current of the EV in steady state operation shall be between  $\pm 2,5$  A DC if the target current of the EV  $< 50$  A, and between  $\pm 5$  % of the target current of the EV if the target current of the EV  $\geq 50$  A.

System A specific test conditions for compliance test in 101.1.2.1 are shown below.

The setup of the test load is shown in Table AA.10 and Figure 132.

**Table AA.10 – System A setup of the test load for regulation of the present current at side B in CCM**

Switches					Circuit parameter setup
$S_{T17}$ , $S_{T18}$	$S_{T19}$	$S_{T20}$	$S_{T21}$	$S_{T22}$	
Closed	Closed	Closed	Open	Open	LT: 0 H $R_{T10}$ : 0 $\Omega$ (bypassed) $U_{T4}$ : not used $U_{T5}$ : an electronic load operating under constant voltage mode shall be used

For 101.1.2.1, step 4), record  $I_{EV\_target}$  and  $I_{EVSE\_SideB}$  at the following operating points: OP1, OP2, OP3, OP4, OP5, OP6 and OP7.

Recommended steps for sweeping the present voltage at side B and present current at side B are shown in Table AA.11.

**Table AA.11 – System A recommended steps for regulation of the present current at side B in CCM**

Step	Action	Description
1	Set $U_{T5} = V_{EVSE\_min}$ .	Communicate; Target battery current = 0 A
2	Set $I_{EV\_target} = I_{EVSE\_min}$ to check OP1.	Communicate; Target battery current = 5 A
3	Set $I_{EV\_target} = I_{EVSE\_max}$ to check OP5.	Communicate; Target battery current = $I_{EVSE\_max}$ (A)
4	Increase $U_{T5}$ up to $V_{EVSE\_SideB} = P_{EVSE\_max} / I_{EVSE\_max}$ to check OP4.	-
5	Set $U_{T5}$ to $V_{EVSE\_max}$ to check OP3.	Before setting $U_{T5}$ to $V_{EVSE\_max}$ , communicate; Target battery current = $P_{EVSE\_max} / V_{EVSE\_max}$ – 5 A
6	Set $U_{T5} = V_{EVSE\_min}$ to check OP2.	-

### AA.3.11 Periodic and random deviation (current ripple at side B during CCM)

Compliance to 101.1.5 shall be checked according to the following tests.

- 1) Connect the EV supply equipment to a test load with a dedicated EV simulator for the system under test. See Figure 129. The setup of the test load in Figure 132 is in Table 120.
- 2) Select the value of  $R_{T10}$  in accordance with  $I_{EVSE\_max}$  and the voltage at which the OP4 in Figure 133 shall be operated. For example, if  $I_{EVSE\_max} = 200$  A and the voltage at OP4 = 400 V,  $R_{T10} = 400$  V / 200 A = 2  $\Omega$ .
- 3) Measure  $A_{T1}$  with an oscilloscope and current probe as specified in Table AA.12.
- 4) Start energy transfer according to the procedure specified by the EV supply equipment manufacturer, with

$$I_{EV\_target1} = I_{EVSE\_min}$$

where

$I_{EV\_target1}$  is the initial target current of the EV simulator for OP1 in Figure 133.

- 5) Wait for  $T_{dmax1}$  until the steady state operation is reached.

$$T_{dmax1} > 1 + \frac{I_{EV\_target1}}{20} \quad (AA.3)$$

where

$T_{dmax1}$  is the time for the present current at side B to reach  $I_{EV\_target1}$  and the steady state, expressed in seconds (s).

- 6) Set the target current of the EV simulator =  $I_{EV\_target2}$  to operate the EV supply equipment at OP4.
- 7) Wait for  $T_{dmax2}$  until the steady state operation is reached.

$$T_{dmax2} > 1 + \frac{I_{EV\_target2} - I_{EV\_target1}}{20} \quad (AA.4)$$

where

$T_{dmax2}$  is the time for the present current at side B to reach  $I_{EV\_target2}$  and the steady state, expressed in seconds (s).

- 8) Measure the maximum peak-to-peak value of the present current at side B after the first order low pass filtering.
- 9) Check that the maximum peak-to-peak value is less than or equal to the limit for each cut-off frequency in Table 118.

The measuring instrument and conditions shall comply with the requirements specified in Table AA.12.

**Table AA.12 – Specification of measuring instrument**

Item	Performance
Oscilloscope	Bandwidth: DC – 20 MHz or more Sampling rate: 1 MS/s or more Record length: 1 M point or more Record span: 1,1 s or more Vertical resolution: 12 bits or more
Current probe	Rated current: Rated boost current of the EV supply equipment at side B or more Bandwidth: DC – 300 kHz or more Measurement accuracy: between $\pm 1$ %

**AA.3.12 Overvoltage protection including load dump**

The EV supply equipment shall control the present voltage at side B by software means to be less than or equal to 110 % of the target voltage of the EV, or target voltage of the EV + 50 V, whichever is more.

In case of the first fault, the following applies.

- When the present voltage at side B is more than the rated maximum voltage of the EV for 400 consecutive ms, the EV supply equipment shall trigger an error shutdown in 1,6 s or less (see 6.3.1.106).
- In addition, the EV supply equipment shall detect the present voltage at side B as shown in Table AA.13 by hardware means (for example, a dedicated overvoltage measurement circuit) to disable the PEC and trigger an emergency shutdown. The setpoints shall be determined by digital communication, based on the target voltage of the EV.

**Table AA.13 – Voltage threshold for emergency shutdown**

Target voltage <sup>a</sup> of the EV $U$	Voltage threshold $V$
$U \leq 500$ V	600
$500$ V < $U \leq 750$ V	900
$750$ V < $U \leq 1\ 000$ V	1 200
<sup>a</sup> See IEC 61851-24:2023, Table A.2.	

Compliance is checked by the following tests.

Test 1:

- 1) Connect the EV supply equipment to a test load with a dedicated EV simulator for the system under test. See Figure 129. The setup of the test load in Figure 132 is in Table 120.
- 2) Start energy transfer with the procedure specified by the EV supply equipment manufacturer.
- 3) The EV supply equipment is operated at the operating point OP4 in Figure 133 and the target voltage of the EV is set at the voltage according to OP4.
- 4) Open  $S_{T17}$  and  $S_{T18}$ .
- 5) Check that  $V_{T8} \leq \max(110\% \text{ of target voltage of the EV; target voltage of the EV} + 50 \text{ V})$ .

NOTE The transient voltage, lasting for 10 ms or less which can appear after the load dump, can be ignored.

**Test 2:**

- 1) Connect the EV supply equipment to a test load with a dedicated EV simulator for the system under test. See Figure 129. The setup of the test load in Figure 132 is in Table 120.
- 2) Start energy transfer with the procedure specified by the EV supply equipment manufacturer.
- 3) The EV supply equipment is operating at the operating point OP4 in Figure 133 and the target voltage of the EV is set at the voltage according to OP4.
- 4) Set  $U_{T5}$  so that  $V_{T8}$  is more than the voltage threshold shown in Table AA.13.
- 5) Check that the EV supply equipment transfers to emergency shutdown in 10 ms or less after setting  $U_{T5}$  in step 4).

**AA.3.13 Power supply to the EV for the actuation of EV disconnection device**

System A EV supply equipment shall provide a power supply to the EV via terminal CP for the actuation of the EV disconnection device ( $S_V1$ ), with a rated voltage of 12 V DC and the rated maximum power of > 24 W.

NOTE By using the 12 V DC power supply from the EV supply equipment as a power source for the actuation of the EV disconnection device, the unexpected closure of the EV disconnection device when the vehicle connector is not mated to the vehicle inlet can be prevented.

Instead of using the 12 V DC power supply from the EV supply equipment, the EV may provide the power source for the actuation of the EV disconnection device. In such case:

- the EV should be capable of reducing the voltage of the side B live parts (DC+/DC–) to < 60 V DC between DC+ and DC–, between DC+ and protective conductor, and DC– and protective conductor in 1 s or less after un-mating of the vehicle connector from the vehicle inlet;
- the EV can continuously monitor the status of the vehicle connector proximity by checking the condition of one or more of the signals CP, CP2, Com1 and Com2.
- the EV should not close the EV disconnection device when the vehicle connector is not mated to the vehicle inlet.

**AA.3.14 Impedance of the side B circuit**

In the time period between T3 and T4 in Figure AA.6, the side B circuit impedance between DC+ and DC– from the reverse current prevention device  $D_S1$  in side B of system A EV supply equipment to the vehicle connector shall be as follows:

- capacitance:  $\leq 1 \mu\text{F}$ ;
- resistance:  $\geq 40 \text{ k}\Omega$ .

*Compliance is checked by design review and inspection.*

*The EV supply equipment manufacturer shall provide circuit diagram and data sheet of the components showing the resistance and the capacitance.*

**AA.3.15 Assistance of welding detection**

The EV supply equipment shall fulfil the following conditions when, from the vehicle inlet to the open EV disconnection device, the capacitance between DC+ and DC– is  $\leq 1 \mu\text{F}$ :

- in 1 s or less after opening the EV disconnection device, the present voltage at side B shall be less than 25 % of the present voltage at side B at the end of the energy transfer;
- in 2 s or less after opening the EV disconnection device, the present voltage at side B shall be < 30 V DC.

Compliance is checked by the following test:

- 1) Connect the EV supply equipment to a test load with a dedicated EV simulator for the system under test. See Figure 129. The setup of the test load in Figure 132 is in Table 120.
- 2) In this test,  $C_{T6}$  shall be set to 1  $\mu$ F.
- 3) Start energy transfer with the procedure specified by the EV supply equipment manufacturer.
- 4) Set the parameters of the test load and the EV simulator so that  $V_{T8}$ , is the rated maximum voltage of the EV supply equipment at side B during energy transfer.
- 5) Stop energy transfer as specified by the EV supply equipment manufacturer.
- 6) If  $A_{T1}$  is < 5 A DC but  $V_{T8}$  is still the rated maximum voltage of the EV supply equipment at side B, open  $S_{T17}$  and  $S_{T18}$ .
- 7) Record the voltage vs time waveform to check the requirement.

### AA.3.16 Specific requirements for temperature-controlled energy transfer

EV supply equipment that allows a rated boost current of the EV supply equipment at side B (see 101.3) shall implement one or more of the following measures in order to ensure safe operation, even under the first fault condition in which the temperature monitoring function of the side B cable assembly has failed during energy transfer.

- The rated boost current of the EV supply equipment at side B shall be less than or equal to the upper limit and the longest duration specified in Table AA.14. The rated boost current of the EV supply equipment at side B shall be reduced to the rated continuous current of the EV supply equipment at side B in 30 s or less after the longest duration has passed. The EV supply equipment shall not supply the rated boost current of the EV supply equipment at side B again until the contact temperature of the side B cable assembly has reached a default state in which the rated boost current of the EV supply equipment at side B can be supplied for the longest duration without being > 90 °C under normal condition.

**Table AA.14 – Maximum boost current for system A EV supply equipment**

Maximum rated current according to IEC 62196-3-1	Maximum boost current	
	Upper limit	Longest duration
400 A DC	600 A DC	5 min
	500 A DC	15 min

- A redundant temperature monitoring function, for example, multiple temperature sensors per side B circuit on the side B cable assembly, each of which is connected to a dedicated temperature measurement circuit in the EV supply equipment.
- Any other means mutually agreed between the EV supply equipment manufacturer and the side B cable assembly manufacturer.

Compliance is checked by design review.

## AA.4 FPT process and communication between the EV supply equipment and the EV for energy transfer control

### AA.4.1 Forward power transfer states

Table AA.15 defines the energy transfer states of the EV supply equipment. The energy transfer states show the physical status of the EV supply equipment. The EV supply equipment shall exchange its energy transfer state with the EV through the control pilot functions and the digital communication.

**Table AA.15 – FPT states of the FPT EV supply equipment**

State		EV connected	EV disconnection device	Energy transfer possible	Description
DC-A	Un-mated	No	Open	No	EV un-mated
DC-B1	Initialization	Yes	Open	No	EV connected / not ready for energy transfer / communication not established / vehicle connector unlatched or latched / EV disconnection device open
DC-B2		Yes	Open	No	EV connected / not ready for energy transfer/ digital communication established / vehicle connector unlatched or latched / EV disconnection device open
DC-B3		Yes	Open	No	EV connected / not ready for energy transfer / digital communication established / vehicle connector latched / EV disconnection device open / other supplemental processes not completed
DC-C	Energy transfer	Yes	Closed	Yes	EV connected / ready for energy transfer / digital communication established / vehicle connector latched / EV disconnection device closed / other supplemental processes completed
DC-D		Yes	Closed	Yes	EV connected / ready for energy transfer / indoor energy transfer area ventilation required / digital communication established / vehicle connector latched / EV disconnection device closed / other supplemental processes completed
DC-B'1	Shutdown	Yes	Closed	Yes	EV connected / energy transfer finished / digital communication maintained / connector latched / EV disconnection device closed
DC-B'2		Yes	Open	No	EV connected / energy transfer finished / digital communication maintained / vehicle connector latched / EV disconnection device open / other supplemental processes completed
DC-B'3		Yes	Open	No	EV connected / energy transfer finished / digital communication maintained / vehicle connector unlatched / EV disconnection device open
DC-B'3-1		Yes	Open	No	EV connected / energy transfer finished / digital communication maintained / vehicle connector latched / EV disconnection device open
DC-B'4		Yes	Open	No	EV connected / energy transfer finished / digital communication finished / vehicle connector unlatched / EV disconnection device open
DC-B'4-1		Yes	Open	No	EV connected / energy transfer finished / digital communication finished / vehicle connector latched / EV disconnection device open
DC-B'4-2		Yes	Open	No	EV connected / energy transfer finished / digital communication finished / vehicle connector unlatched / EV disconnection device open
DC-E	Error	Yes	Open	No	EV supply equipment un-mated from the EV / EV supply equipment disconnected from the supply network, EV supply equipment loss of supply network power or control pilot short-circuit to the protective conductor
DC-F	Malfunction	Yes	Open	No	Other EV supply equipment problem

FPT control process and states are shown in Table AA.16.

**Table AA.16 – FPT control process and states of the FPT EV supply equipment**

FPT control process		State	High level action <sup>a</sup>
Initialization	Handshaking	DC-A	Vehicle connector un-mated
		DC-B1	Vehicle connector mated
		DC-B1	Wake up of the SECC and EVCC
		DC-B1	Digital communication setup
		DC-B1→DC-B2	Digital communication established, parameters exchanged, and compatibility check successfully completed
	Energy transfer preparation	DC-B2→DC-B3	Vehicle connector latched
		DC-B3	Insulation resistance check for side B live parts (DC+ and DC-)
Energy transfer	DC-C or DC-D	EV disconnection device closed	
	DC-C or DC-D	Energy transfer by current demand (CCM)	
	DC-C or DC-D	Energy transfer by voltage demand (CVM) (under consideration)	
	DC-C or DC-D→DC-B'1	Current suppression	
	DC-C or DC-D	Renegotiate parameter limits (option)	
Shutdown (case 1)	DC-B'1	Zero current confirmed	
	DC-B'1→DC-B'2	Welding detection (by EV, option)	
	DC-B'2	EV disconnection device open	
	DC-B'2	Present voltage at side B voltage verification	
	DC-B'3	Vehicle connector unlatched	
	DC-B'4	End of charge at digital communication level	
	DC-A	Connector un-mated	
Shutdown (case 2) <sup>b</sup>	DC-B'1	Zero current confirmed	
	DC-B'1→DC-B'2	Welding detection (by EV, option)	
	DC-B'2	EV disconnection device open	
	DC-B'2	Present voltage at side B voltage verification	
	DC-B'3-1	Vehicle connector remains latched	
	DC-B'4-1	End of charge at communication level	
	DC-B'4-2	Vehicle connector unlatched or remain latched	
	DC-A or DC-B1	Vehicle connector un-mated or remain mated	
<sup>a</sup> The order of actions does not refer to the procedure of FPT control process.			
<sup>b</sup> In some use cases, such as billing service, the vehicle connector can continue to be latched after energy transfer is finished.			

#### AA.4.2 Communication measures

Communication between the EV supply equipment and the EV is carried out through the control pilots (CP, CP2 and CP3), proximity circuit (CS), and the circuits for digital communication (Com1 and Com2). CP and CP2 communicate signals such as "ready to charge" and "end of charge" from the EV supply equipment to the EV. CP3 is used to communicate instructions to start energy transfer or shutdown, from the EV to the EV supply equipment. Numerical parameters in IEC 61851-24:2023, Annex A, such as rated values of the EV supply equipment and rated maximum voltage of the EV are exchanged through Com1 and Com2.

**AA.4.3 Forward power transfer control process**

**AA.4.3.1 Forward power transfer flow diagram and sequence diagram**

The FPT process of system A shall conform to the flow diagram as shown in Figure AA.5. Figure AA.6 gives the FPT control sequence under normal conditions.

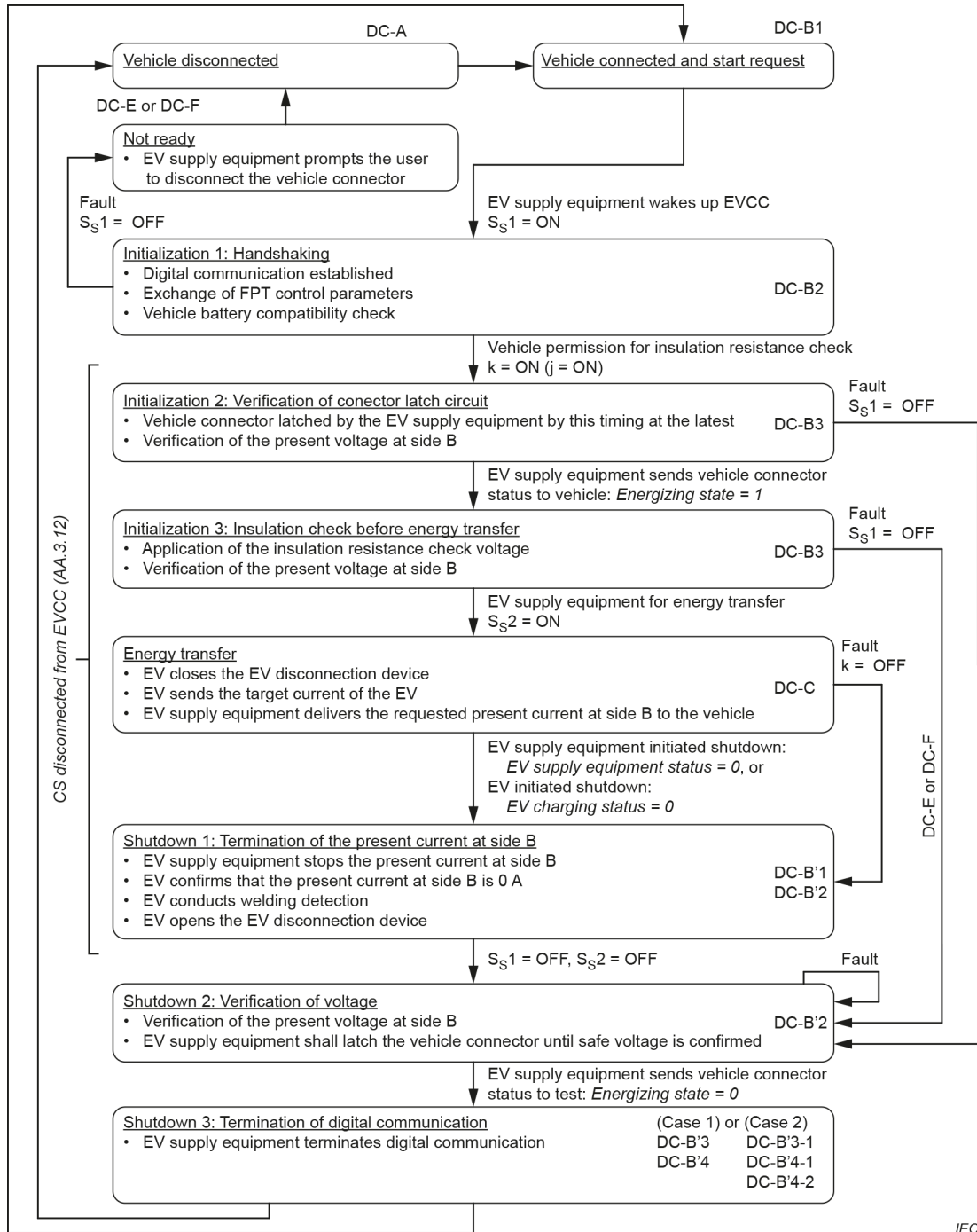

NOTE *Italic* means the parameters exchanged via digital communication as defined in IEC 61851-24:2023, Annex A.

**Figure AA.5 – Flow diagram for forward power transfer**

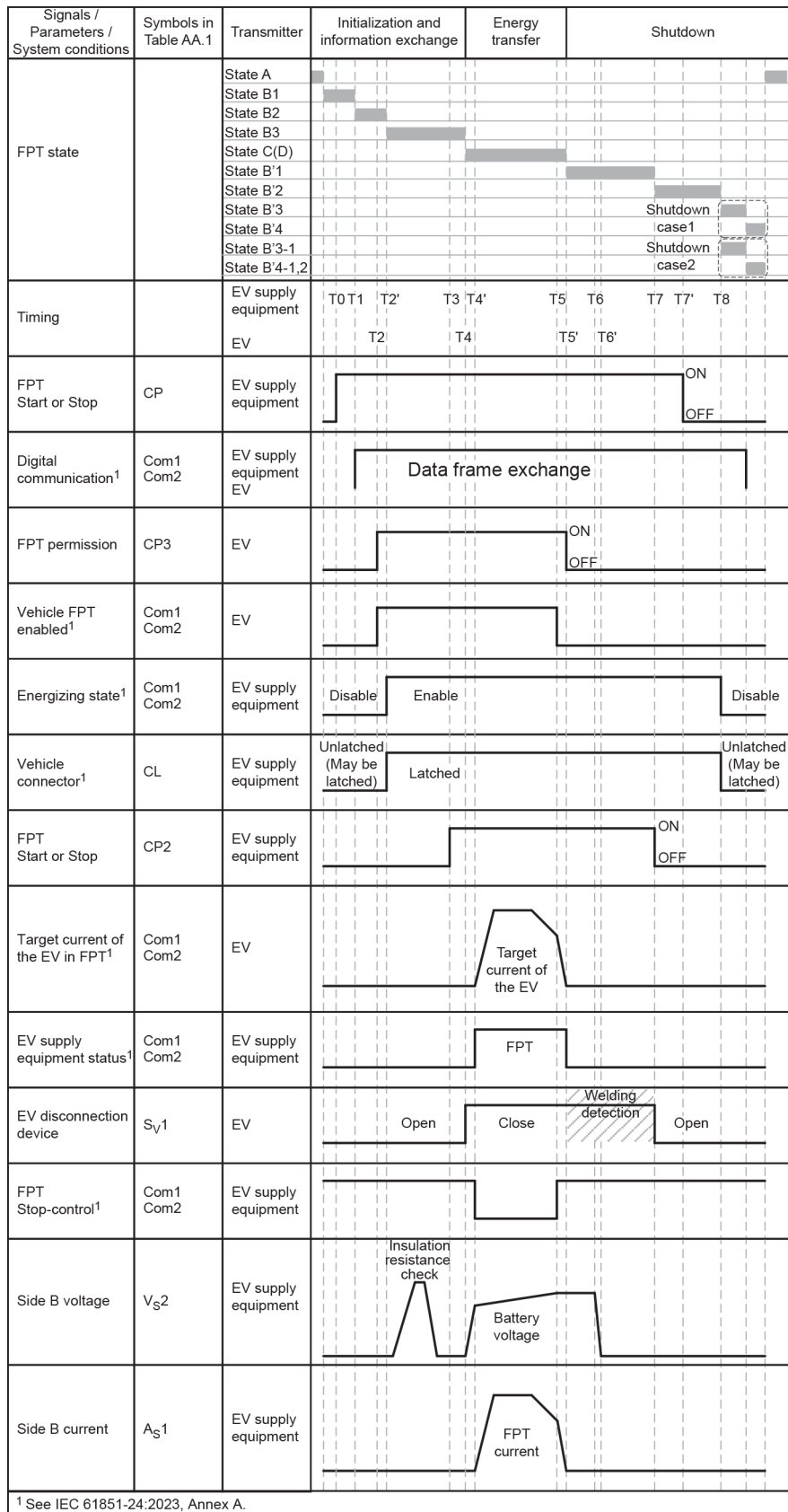

Figure AA.6 – Sequence diagram for forward power transfer

### AA.4.3.2 Start of forward power transfer

When the communication session is initiated by system A EV supply equipment,  $S_S1$  shall be closed. The switch  $S_S2$  shall be open until the end of insulation resistance check in AA.4.3.3.

*Compliance is checked by measuring the voltages a) and b) under the operation with a test load and EV simulator. Connect the EV supply equipment to a test load with a dedicated EV simulator for the system under test. See Figure 129.*

- a)  $V_{T4}$  for  $S_S1$ .
- b)  $V_{T5}$  for  $S_S2$ .

*For this test, the EV simulator shall be equipped with the EV part of the circuit diagram in Figure AA.1, and shall control the test load and the EV supply equipment according to the FPT sequence specified in Figure AA.5 and Figure AA.6. The setup of the test load in Figure 132 is in Table 120.*

### AA.4.3.3 Insulation resistance check before energy transfer

The insulation resistance check shall not start until the EV provides system A EV supply equipment with a permission signal through CP3, and permission parameters by digital communication as shown in IEC 61851-24:2023, Annex A. Before the insulation resistance check, system A EV supply equipment shall inform the EV through digital communication that the vehicle connector is latched.

The insulation resistance check shall be performed according to 6.3.1.105 and the following procedure.

- a) Before the insulation resistance check, the EV supply equipment shall measure  $V_{S2}$  and confirm that the EV disconnection device is open.  $V_{S2}$  shall be  $< 30$  V DC. If  $V_{S2}$  is  $\geq 30$  V DC, the EV supply equipment shall trigger an error shutdown (see Figure AA.5).
- b) The present voltage at side B shall be
  - the lower value between the "target voltage of the EV" (H'102.1, H'102.2) or the "available maximum voltage of the EV supply equipment" (H'108.1, H'108.2), if both the system A EV supply equipment and EV are compatible with "high voltage control" (H'118.0.2, H'110.0.2) according to IEC 61851-24, and are compatible with a present voltage at side B  $> 500$  V DC, or
  - 500 V DC.

For both cases, the accuracy of the present voltage at side B shall be between  $\pm 5$  % and the voltage shall be continuously applied at side B for 1 s or more.

- c) During the insulation resistance check, the fault between side B live parts (DC+/DC-) and the protective conductor shall be monitored according to AA.3.1.2. When a fault between side B live parts (DC+/DC-) and the protective conductor is detected, an error shutdown shall be performed.
- d) After the insulation resistance check, it shall be confirmed that the voltage at  $V_{S2}$  is  $\leq 30$  V DC. Then, the EV supply equipment shall inform the EV of the termination of insulation resistance check by closing  $S_S2$ .

NOTE 1 The rated maximum voltage of the EV supply equipment at side B and thus the insulation resistance check voltage can be limited to lower voltage by local regulations.

*The compliance of the insulation resistance check function shall be confirmed with the following test.*

- 1) *Connect the EV supply equipment to a test load with a dedicated EV simulator for the system under test. See Figure 129. The setup of the test load in Figure 132 is in Table 120. Switches  $S_{T17}$  and  $S_{T18}$  in the test load shall remain open during the test.*

2) The DUT shall be checked under all test scenarios specified in Table AA.17.

**Table AA.17 – Test scenarios**

Test scenarios	Fault resistances (R <sub>T5</sub> and R <sub>T6</sub> )	Switch to trigger the fault
Scenario 1	Not used	-
Scenario 2	$U^a \times 100$	S <sub>T11</sub>
Scenario 3	Sufficiently low resistance <sup>b</sup>	S <sub>T11</sub>
Scenario 4	$U^a \times 100$	S <sub>T13</sub>
Scenario 5	Sufficiently low resistance <sup>b</sup>	S <sub>T13</sub>
<sup>a</sup> According to AA.4.3.3 b). <sup>b</sup> Select sufficiently low resistance to represent 0 Ω insulation fault. The examiner can select the appropriate value for the resistance.		

3) The DUT shall satisfy the following requirements.

a) *Insulation resistance check voltage: Insulation resistance check voltage shall comply with the requirement in AA.4.3.3 b) in test scenario 1. The DUT shall keep the insulation resistance check voltage for more than 0,2 s after the voltage reached the required value.*

NOTE 2 Some DUT needs a certain time period to reach the insulation resistance check voltage.

b) *Detection of an insulation fault: In the scenarios 2, 3, 4 and 5, the DUT shall judge the insulation fault in 1 s or less after the insulation resistance check voltage reached the required value.*

c) *For scenario 1, the DUT shall transition to the next FPT state.*

d) *For scenarios 2, 3, 4 and 5, the DUT shall perform the following process.*

- *Notify the EV (EV simulator) the insulation fault by digital communication. The DUT shall use data bit H'109.5.(1) specified in IEC 61851-24:2023, Annex A.*
- *Reduce the present voltage at side B in 1 s or less.*
- *Trigger an error shutdown.*

#### **AA.4.3.4 Energy transfer**

System A EV supply equipment shall continuously monitor the target current of the EV. The present current at side B shall be changed to the target current of the EV, according to CCM requirements in 101.1.2.1 and 101.1.3. The characteristics of present current at side B shall meet the requirements in Clause AA.5.

#### **AA.4.3.5 Shutdown**

##### **AA.4.3.5.1 Normal shutdown**

System A EV supply equipment shall comply with the following procedure for normal shutdown.

- a) In addition to the request from the EV and the user-requested shutdown, the EV supply equipment shall terminate energy transfer in 30 s or less after the present voltage at side B becomes more than or equal to the target voltage of the EV + 10 V DC.
- b) The EV supply equipment shall notify the EV of the start of the shutdown process by digital communication.
- c) The EV supply equipment shall reduce the present current at side B to ≤ 5 A DC with the current descending speed specified in Table AA.21.

- d)  $S_{S1}$  and  $S_{S2}$  shall not be open until the welding detection of the EV disconnection device by the EV is finished. The status of the welding detection is indicated via digital communication.
- e) After  $S_{S1}$  and  $S_{S2}$  open, it shall be confirmed that  $V_{S2}$  is  $\leq 30$  V DC. The EV supply equipment shall keep the vehicle connector latched, if the voltage at  $V_{S2}$  is  $> 30$  V DC.

The EV supply equipment may stop FPT any time after the present voltage at side B is more than the target voltage of the EV.

The rated maximum voltage of the EV should be more than or equal to the target voltage of the EV + 10 V (+ voltage drop between the vehicle inlet and battery system).

Table AA.18 and Table AA.19 define the normal shutdown time, actions and criteria.

**Table AA.18 – Normal shutdown times and criteria**

Trigger	Response time of EV supply equipment to start normal shutdown process	Maximum time to near zero current (5 A) from the start of normal shutdown process	Maximum time to reach connector unlatched
EV	$\leq 0,5$ s from trigger	$\leq 3$ s and $\Delta A_{S1} \geq -100$ A/s	$\leq 7,5$ s
EV supply equipment	According to the specification given by the EV supply equipment manufacturer		

**Table AA.19 – Actions and message parameters for normal shutdown**

Step	EV			EV supply equipment		
	Action	Message parameter	Criterion	Action	Message parameter	Criterion
1	Request of normal shutdown	H'102.5.0 = 0 or H'102.5.1 = 1 and H'102.3 = 0	Send the parameters to the EV supply equipment	n.a	n.a	n.a
2 <sup>a</sup>	n.a	n.a	n.a	Notify the EV of start of normal shutdown	H'109.5.5 = 0	Send the parameter to the EV
3	n.a	n.a	n.a	FPT current control	n.a	$\leq 3$ s and $\Delta A_{S1} \geq -100$ A/s
4	n.a	n.a	n.a	Notification to the EV	H'109.5.0 = 1	Send the message to the EV when the current drops to $\leq 5$ A DC
5	Welding detection	H'102.5.3 = 1	Welding detection time $\leq 4$ s  Send the message to the EV supply equipment after finishing welding detection	n.a	n.a	n.a
6	n.a	n.a	n.a	$S_{S1}, S_{S2} =$ Open	n.a	$\leq 1,5$ s from the end of step 5

Step	EV			EV supply equipment		
	Action	Message parameter	Criterion	Action	Message parameter	Criterion
7	n.a	n.a	n.a	Voltage removal	n.a	$\leq 2$ s and $V_{S2} \leq 30$ V DC from the end of step 6
8	n.a	n.a	n.a	Unlatched or remain latched	n.a	Specified by the EV supply equipment manufacturer

<sup>a</sup> When the EV supply equipment triggers normal shutdown, the shutdown process starts from step 2.

Compliance is checked by the following test.

- 1) Connect the EV supply equipment to a test load with a dedicated EV simulator for the system under test. See Figure 129. The setup of the test load in Figure 132 is in Table 120.
- 2) Start energy transfer with the procedure specified by the EV supply equipment manufacturer.
- 3) Operate at OP4.
- 4) Start measuring  $A_{T1}$  and  $V_{T8}$ .
- 5) Send a message parameter, see Table AA.19, from the EV simulator to the EV supply equipment to trigger normal shutdown.
- 6) Check the descending speed of the present current at side B with the required value specified in Table AA.21.
- 7) After  $A_{T1}$  drops to  $< 5$  A DC, measure  $V_{T4}$  and  $V_{T5}$  to check that  $S_{S1}$  and  $S_{S2}$  are not open until the EV simulator sent message 'H102.5.3=1' to the EV supply equipment.
- 8) Open  $S_{T17}$  and  $S_{T18}$  and send message 'H102.5.3=1' from the EV simulator to the EV supply equipment. Confirm that  $S_{S1}$  and  $S_{S2}$  opened.
- 9) Check that the vehicle connector remains latched until  $V_{T8}$  is  $< 30$  V DC.
- 10) Repeat the test from step 1) to step 9), replacing step 5) with the following.  
Change  $U_{T5}$  to a voltage more than the target voltage of the EV + 10 V DC but less than the rated maximum voltage of the EV to trigger a normal shutdown.

#### AA.4.3.5.2 Error shutdown

System A EV supply equipment shall comply with the following procedure for error shutdown.

- a) The EV supply equipment shall notify the EV of start of an error shutdown process by digital communication.
- b) The EV supply equipment shall reduce the present current at side B to  $\leq 5$  A DC with the current descending speed specified in Table AA.21.
- c) If the error shutdown is triggered by the EV,  $S_{S1}$  and  $S_{S2}$  shall not open until the welding detection of the EV disconnection device by the EV is finished. The status of welding detection is indicated via digital communication.
- d) If the error shutdown is triggered by system A EV supply equipment,  $S_{S1}$  and  $S_{S2}$  shall be opened in 0,5 s or less after b).
- e) After  $S_{S1}$  and  $S_{S2}$  open, it shall be confirmed that  $V_{S2}$  is  $\leq 30$  V DC. The EV supply equipment shall keep the vehicle connector latched, if the voltage at  $V_{S2}$  is  $> 30$  V DC.

*Compliance is checked by the following test.*

- 1) *Connect the EV supply equipment to a test load with a dedicated EV simulator for the system under test. See Figure 129. The setup of the test load in Figure 132 is in Table 120.*
- 2) *Start energy transfer with the procedure specified by the EV supply equipment manufacturer.*
- 3) *Operate at OP4.*
- 4) *Send a message parameter, see Table AA.7, from the EV simulator to the EV supply equipment to trigger error shutdown.*
- 5) *Measure  $A_{T1}$  and  $V_{T8}$  continuously.*
- 6) *Check that the current descending speed of the present current at side B is  $> 200$  A/s.*
- 7) *After  $A_{T1}$  drops to  $< 5$  A DC, wait 4 s, then send the message "H102.5.3=1" to the EV supply equipment.*
- 8) *Open  $S_{T17}$  and  $S_{T18}$  after  $S_{S1}$  and  $S_{S2}$  are opened.*
- 9) *Confirm that the vehicle connector remains latched until  $V_{T8}$  is  $< 30$  V DC.*

#### **AA.4.3.5.3 Emergency shutdown**

System A EV supply equipment shall start an emergency shutdown as follows, when detecting the loss of electrical continuity of CP3.

- a) *The EV supply equipment shall reduce the present current at side B to  $\leq 5$  A DC in 30 ms or less.*
- b) *If the EV supply equipment uses CP3 as emergency shutdown detection,  $S_{S1}$  and  $S_{S2}$  shall not open until the status (flag = 1) of the welding detection is received from the EV.*
- c) *After  $S_{S1}$  and  $S_{S2}$  open, it shall be confirmed that  $V_{S2}$  is  $\leq 30$  V DC. The EV supply equipment shall keep the vehicle connector latched, if the voltage at  $V_{S2}$  is  $> 30$  V DC.*

*Compliance is checked by the following test.*

- 1) *Connect the EV supply equipment to a test load with a dedicated EV simulator for the system under test. See Figure 129. The setup of the test load in Figure 132 is in Table 120.*
- 2) *Start a communication session with the procedure specified by the EV supply equipment manufacturer.*
- 3) *Operate at OP4.*
- 4) *Open  $S_{T5}$ .*
- 5) *Measure  $A_{T1}$  and  $V_{T8}$  continuously.*
- 6) *Check that  $A_{T1}$  drops to  $< 5$  A DC in 30 ms or less from step 4).*
- 7) *Measure  $V_{T4}$  and  $V_{T5}$  to check that  $S_{S1}$  and  $S_{S2}$  are not open until the EV simulator sent message "H102.5.3=1" to the EV supply equipment.*
- 8) *Open  $S_{T17}$  and  $S_{T18}$  after  $S_{S1}$  and  $S_{S2}$  are opened.*
- 9) *Confirm that the vehicle connector remains latched until  $V_{T8}$  is  $< 30$  V DC.*

#### **AA.4.4 Measuring current and voltage at side B**

The present voltage and present current at side B shall be continuously monitored and reported in 0,5 s or less including measurement delay and digital communication transmission delay. See Figure AA.7.

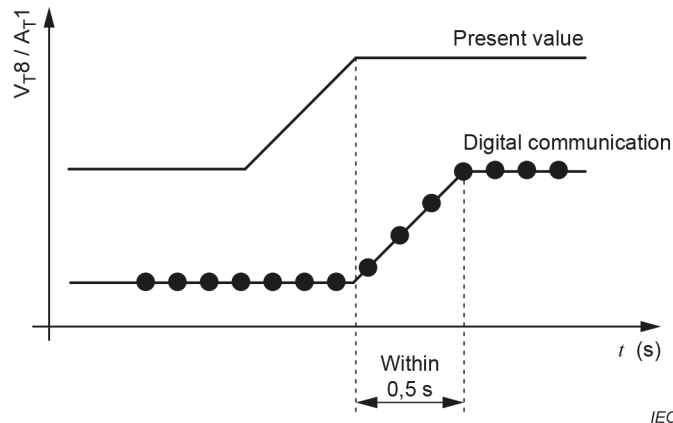

**Figure AA.7 – Representation of the delay between the measurement and the digital communication transmission for system A**

Compliance is checked by the following tests.

**Test 1:**

- 1) Connect the EV supply equipment to a test load with a dedicated EV simulator for the system under test. See Figure 129. The setup of the test load in Figure 132 is in Table 120.
- 2) Start energy transfer with the procedure specified by the EV supply equipment manufacturer.
- 3) Operate at OP4.
- 4) After confirming operation at OP4, the EV simulator shall change the target current of the EV to  $I_{EVSE\_MAX} - 20$  A DC with the rate of demand value specified in Table AA.20.
- 5) Measure  $A_{T1}$  and digital communication.
- 6) Confirm that the digital communication delay is 0,5 s or less.

**Test 2:**

- 1) Connect the EV supply equipment to a test load with a dedicated EV simulator for the system under test. See Figure 129. The setup of the test load in Figure 132 is in Table 120.
- 2) Start energy transfer with the procedure specified by the EV supply equipment manufacturer.
- 3) Operate at OP1.
- 4) After confirming operation at OP1, the EV simulator shall change the target current of the EV to  $I_{EVSE\_MIN} + 20$  A DC with the rate of demand value specified in Table AA.20.
- 5) Measure  $A_{T1}$  and digital communication.
- 6) Confirm that the digital communication delay is 0,5 s or less.

**Test 3:**

- 1) Connect the EV supply equipment to a test load with a dedicated EV simulator for the system under test. See Figure 129. The setup of the test load in Figure 132 is in Table 120.
- 2) Start energy transfer with the procedure specified by the EV supply equipment manufacturer.
- 3) Operate at OP1.
- 4) After confirming operation at OP1, set the target voltage of the EV to  $V_{EVSE\_MAX}$ .
- 5) Measure  $V_{T8}$  and digital communication.
- 6) Confirm that the digital communication delay is 0,5 s or less.

**Test 4:**

- 1) Connect the EV supply equipment to a test load with a dedicated EV simulator for the system under test. See Figure 129. The setup of the test load in Figure 132 is in Table 120.
- 2) Start energy transfer with the procedure specified by the EV supply equipment manufacturer.
- 3) Operate at OP3.
- 4) After confirming operation at OP3, set the target voltage of the EV to  $V_{EVSE\_MIN}$ .
- 5) Measure  $V_{T8}$  and digital communication.
- 6) Confirm that the digital communication delay is 0,5 s or less.

The accuracy of measure current and voltage at side B measurement reported via digital communication of system A shall be between the following values:

- measured current at side B:  $\pm(1,5\%$  of the present current at side B + 1) A;
- measured voltage at side B  $\leq 500$  V:  $\pm 5$  V;
- measured voltage at side B  $> 500$  V:  $\pm 10$  V.

Compliance test is specified in 6.3.1.102.

See Figure AA.8 for a more precise definition of the accuracy of side B measurement with respect to the target current of the EV and the present current at side B defined in 101.1.2.1.

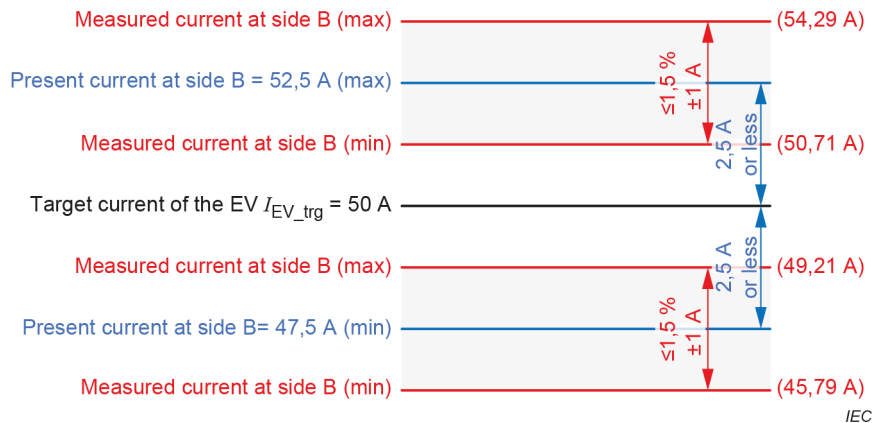

**Figure AA.8 – Acceptable range of the measured current at side B (target current of the EV  $I_{EV\_trg} = 50$  A)**

### AA.5 Response to an EV command on charge current

System A EV supply equipment shall supply a present current at side B to the EV using CCM with the EV as the master and EV supply equipment as the slave. Recommended specification for the target current of the EV and the response performance of system A EV supply equipment are given in Table AA.20 and Table AA.12 for the EV, and in Table AA.21 and Figure AA.10 for system A EV supply equipment.

NOTE Table AA.20 and Figure AA.5 also apply to the applicable maximum current of the EV supply equipment at side B in BPT operating under BPT seamless-switchover mode.

**Table AA.20 – Recommended specification of target current of the EV**

Item	Symbol	Condition	Specification		
			Minimum	Maximum	Unit
Range for the target current of the EV	$I_{req}$	n.a.	0	Applicable maximum current of the EV supply equipment (IEC 61851-24:2023, Annex A)	A
Rate of demand value change	$\Delta I_{req1}$	n.a.	-20	20	A/s

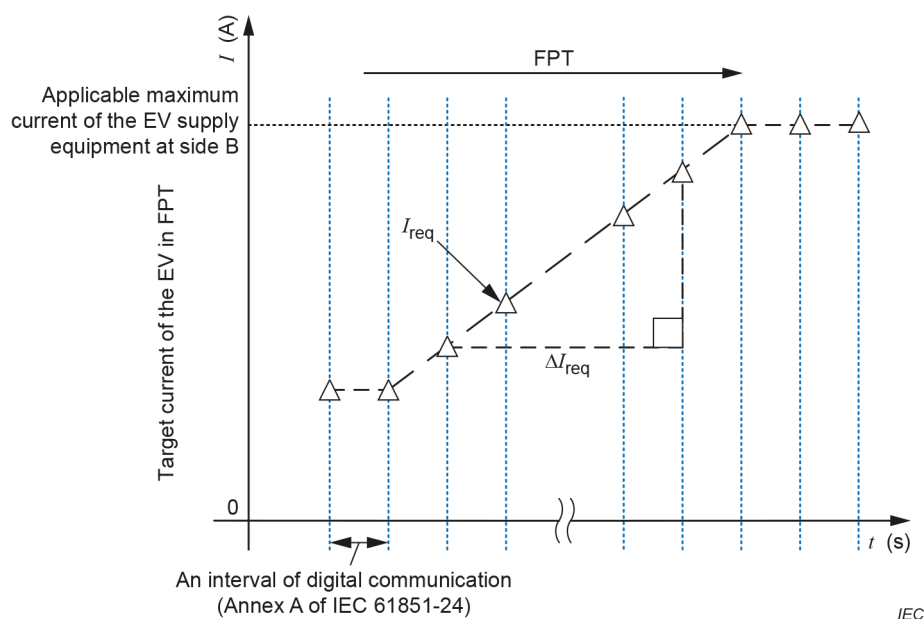

IEC

**Figure AA.9 – Change in the target current requested by the EV****Table AA.21 – Requirements for the side B performance of EV supply equipment**

Item	Symbol	Condition	Specification			
			Minimum	Maximum	unit	
Accuracy of the present current at side B	$I_{dev}$	Target current of the EV	0 A to 5 A	0 ( $I_{dev\_Min}$ )	$I + 2,5$ A ( $I_{dev\_Max}$ )	A DC
			5 A to 50 A	$I - 2,5$ A ( $I_{dev\_Min}$ )	$I + 2,5$ A ( $I_{dev\_Max}$ )	
			50 A to 400 A	$I \times 95$ % ( $I_{dev\_Min}$ )	$I \times 105$ % ( $I_{dev\_Max}$ )	
Control delay to the target current of the EV	$T_d$	n.a.	n.a.	1,0 ( $T_d\_Max$ )	s	
Present current at side B response speed	$\Delta I_{pres\_sideB1}$	During energy transfer	20	n.a.	A/s	
Present current at side B descending speed <sup>b</sup>	$\Delta I_{pres\_sideB2}$	Normal shutdown	100	200		
		Error shutdown	200	n.a.		
		Emergency shutdown	200 <sup>a</sup>	n.a.		

- <sup>a</sup> In case of disconnection of CP, CP2 or CP3 during energy transfer, faster reduction of the present current at side B is required. See AA.3.8.2.
- <sup>b</sup> The requirement for the present current at side B descending speed also applies to the BPT EV supply equipment. All the other values in this table are not applicable to the BPT EV supply equipment.

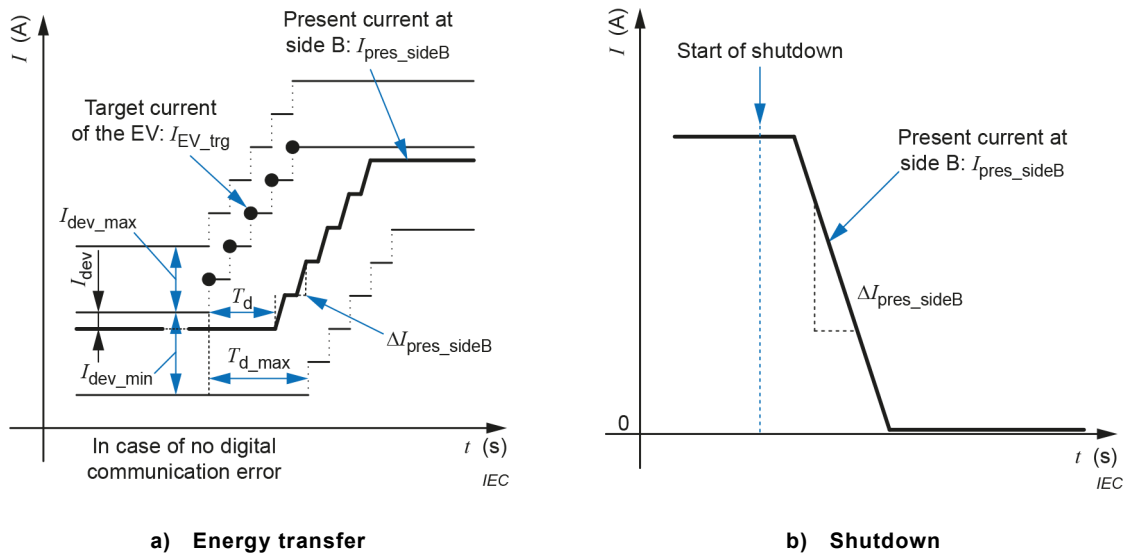

**Figure AA.10 – Side B performance of EV supply equipment**

## AA.6 Bidirectional power transfer (optional)

### AA.6.1 General

Vehicle-to-load (V2L), vehicle-to-home (V2H) and vehicle-to-grid (V2G) implementations/use cases are under consideration.

NOTE In the following country, the requirements for RPT EV supply equipment are a matter of national consideration, for example, as described in the Guidelines of charge/discharge system for electric vehicle V2H/L DC version: JP.

### AA.6.2 Circuit diagram

An example for a system A BPT EV supply equipment is shown in Figure AA.11.

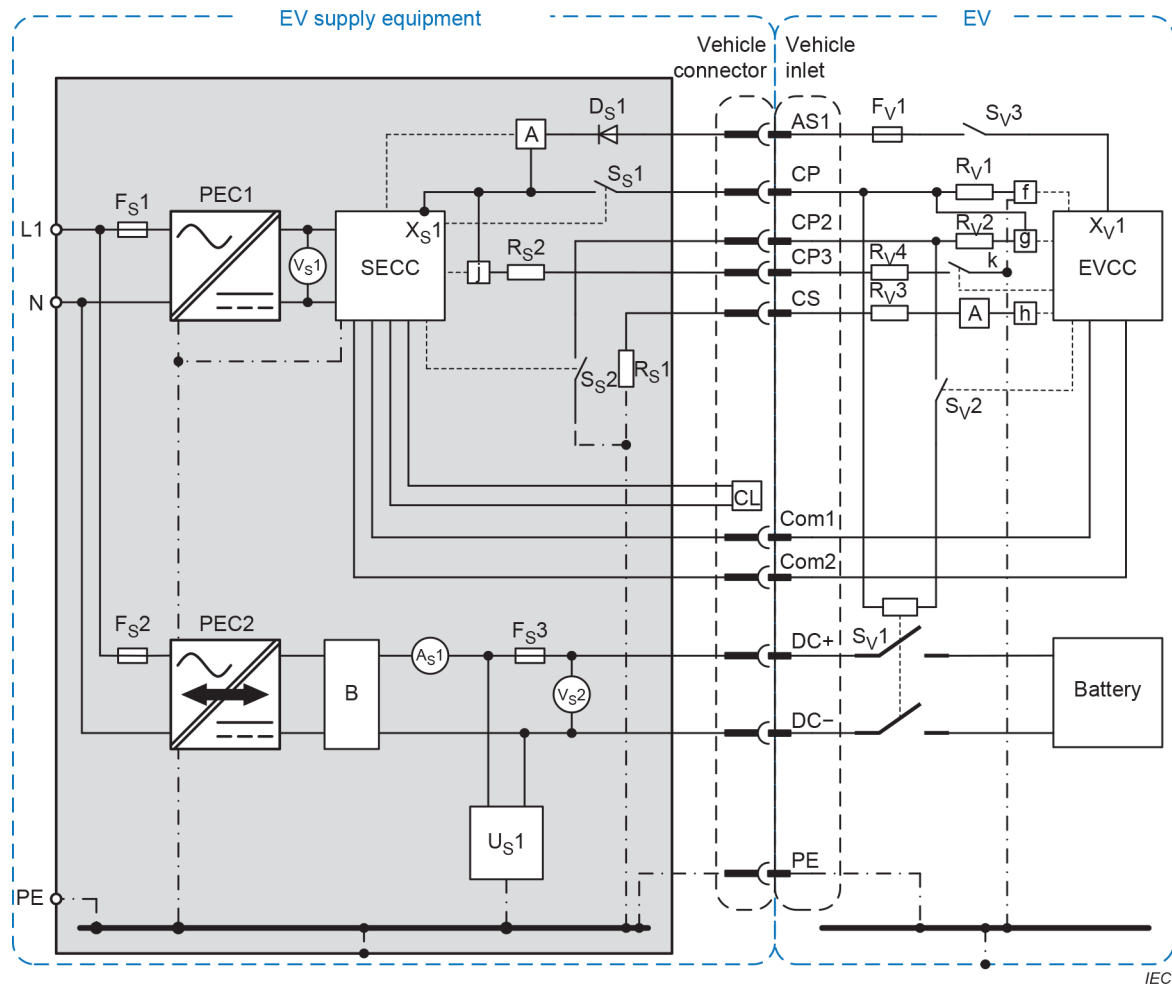

IEC

**Key**

L1, N	AC or DC supply network	$D_S$	diode in the EV supply equipment
PE	protective conductor contact	$S_S$	switch or relay in the EV supply equipment
CP, CP2, CP3, CS	control pilot conductor contacts of system A	$S_V, k$	switch or relay in the EV
Com1, Com2	digital communication conductor contacts	$A_S$	ammeter in the EV supply equipment
DC+	positive terminal of side B	$R_S$	resistor in the EV supply equipment
DC-	negative terminal of side B	$R_V$	resistor in the EV
SECC	supply equipment communication controller	$U_S$	earth leakage current measurement device
EVCC	electric vehicle communication controller	$V_S$	voltmeter in the EV supply equipment
PEC	power electronic converter	$F_S$	over-current protection device
f, g, h, j	optocoupler	A	unintentional current flow prevention circuit
$X_V$	voltage source in the EV	CL	vehicle connector lock and latch monitoring circuit
$X_S$	voltage source in the EV supply equipment	B	pre-charge circuit

NOTE 1  $D_{S1}$  is a reference example. It prevents reverse current to the auxiliary battery.

NOTE 2  $A_{S1}$  is optional.

**Figure AA.11 – Circuit diagram of a system A BPT EV supply equipment and EV**

The definition and description of symbols and terms in figures are specified in Table AA.1. The values of the parameters for the circuit diagram are specified in Table AA.2.

### **AA.6.3 Functional requirements**

#### **AA.6.3.1 General**

In addition to the functional requirements specified in 6.3.1.1, the BPT EV supply equipment shall draw a current from the EV in RPT, according to the limits communicated by the EV (for example, maximum available current, maximum available voltage) and the supply network.

NOTE The maximum available current of the battery system is shown in IEC 61851-24:2023, Table A.7.

The BPT EV supply equipment and the EV shall also implement a means to disable BPT according to the requests from the EV, user or the supply network.

Additional information for BPT is shown in Annex DD.

The following functions shall be provided by the BPT EV supply equipment:

- compatibility check for BPT (AA.6.3.2);
- information that the BPT EV supply equipment is compatible with RPT (AA.6.3.2, AA.6.3.3);
- specific requirements for the latching of the vehicle connector (AA.3.6).

#### **AA.6.3.2 Compatibility check for BPT**

BPT shall be managed by both the EV and the BPT EV supply equipment. The BPT shall only be activated if the compatibility check between the EV and the BPT EV supply equipment is successfully completed.

#### **AA.6.3.3 Specific requirements for connection with a EV which does not support reverse power transfer (RPT)**

Unless otherwise specified, the BPT EV supply equipment shall be capable to provide energy transfer to an EV which does not support RPT.

A BPT EV supply equipment which is not capable to provide energy transfer to an EV which does not support RPT should display a written label that clearly indicates the incapability.

NOTE AA.6.3.3 is not applicable to the RPT EV supply equipment or equipment specifically designed for RPT, for example, a portable vehicle-to-load (V2L) equipment.

#### **AA.6.3.4 Pre-charge for BPT to limit the inrush current**

The pre-charge circuit shall be designed so that the inrush current shall be < 20 A when the EV disconnection device is closed (see AA.3.9).

#### **AA.6.3.5 Auxiliary power supply from the EV (optional)**

The EV may provide an optional function in which the auxiliary power to the EV supply equipment is supplied through the optional pin of the vehicle connector. In such cases, the BPT EV supply equipment may be started (and operated) by the auxiliary power supplied from the EV, and the BPT EV supply equipment shall draw the auxiliary power through the terminal A<sub>S</sub>1 shown in Figure AA.7.

NOTE The cigarette lighter socket can be used if the BPT EV supply equipment compatible with the auxiliary power supply from the EV is equipped with a 12 V cigarette-lighter cable assembly which can be connected to the cigarette lighter socket of the EV. In order to start BPT after the connection, it is possible the user needs to activate the EV in the accessory mode, for example, by pressing the power button once.

If the optional function is used, the BPT EV supply equipment shall be equipped with the unintentional current prevention circuit at the connection of the auxiliary power line  $A_S1$ , see top left of Figure AA.9, to prevent an unintentional current flow during the energy transfer stage. If the requirements are not satisfied, the BPT EV supply equipment shall transfer to shutdown stage.

The DC/DC PEC for auxiliary power supply, if any, shall be activated in 1 s or more after the closure of the EV disconnection device.

*Compliance is checked by the following test.*

- 1) *Connect the BPT EV supply equipment to a test load with a dedicated EV simulator for the system under test. See Figure 129.*
- 2) *Supply 12 V DC to  $A_S1$ .*
- 3) *Start FPT or RPT.*
- 4) *Measure  $A_{T2}$  while the current is flowing through the side B circuit.*
- 5) *Confirm that  $A_{T2}$  is zero in 3).*
- 6) *Bypass the unintentional current flow prevention circuit for the EV supply equipment (connect input and output of the circuit) in BPT EV supply equipment to simulate malfunction of the circuit.*
- 7) *Confirm that the BPT EV supply equipment terminates energy transfer and transfers to shutdown stage.*

*For 5) and 6), an alternative compliance test decided between the certification body and the BPT EV supply equipment manufacturer may be applied with considering the configuration of unintentional current flow prevention circuit for the BPT EV supply equipment.*

*If the circuit is consisted with 2 pole contactor and operation of that circuit can be checked with the pole for monitoring, compliance may be checked by the inspection.*

#### **AA.6.3.6 Control circuit supply integrity**

In addition to 6.3.1.108, where loss of voltage of the auxiliary circuit for the SECC could unable the SECC to perform its intended function, means to ensure continued operation of the auxiliary circuit at least until the termination of the communication session (BDC-B'4) as defined in AA.6.4.2 shall be provided.

NOTE If a BPT EV supply equipment has grid-independent operating function, means such as battery backup or an AC power supply for the control circuit can be implemented.

The use of batteries as a power supply for auxiliary circuits is under consideration.

#### **AA.6.3.7 Protection against under-voltage at the vehicle connector**

The BPT EV supply equipment shall perform an error shutdown and disconnect side B to prevent under-voltage at the battery system, if the voltage at the vehicle connector drops to a value less than the minimum limit sent by the EV.

*Compliance is checked by the following test.*

- 1) *Connect the EV supply equipment to a test load with a dedicated EV simulator for the system under test. See Figure 129. The setup of the test load in Figure 132 is in Table AA.22.*

**Table AA.22 – Setup of test load for protection against under-voltage at the vehicle connector**

Switches					Circuit parameter setup
S <sub>T</sub> 17, S <sub>T</sub> 18	S <sub>T</sub> 19	S <sub>T</sub> 20	S <sub>T</sub> 21	S <sub>T</sub> 22	
Close	Close	Close	Open	Open	L <sub>T</sub> : 0 H R <sub>T</sub> 10: 0 Ω (bypassed) U <sub>T</sub> 4: Not used U <sub>T</sub> 5: A power supply operating under constant voltage mode shall be used

- 2) Measure A<sub>T</sub>1 and V<sub>T</sub>8 continuously.
- 3) Start RPT with the procedure specified by the BPT EV supply equipment manufacturer.
- 4) Using the EV simulator, communicate the following data or message to the BPT EV supply equipment via digital communication.
  - Minimum battery voltage: 250 V DC
  - Maximum available current for RPT: maximum operating current of BPT EV supply equipment.
- 5) Confirm that V<sub>T</sub>8 is energized at the rated voltage and the BPT EV supply equipment is operating at the designated voltage and current.
- 6) Simulate under-voltage at the vehicle connector as follows and check the results.
  - Set U<sub>T</sub>5 to a voltage less than the minimum battery voltage.
  - Verification criterion: see Table AA.5.
- 7) Check that the BPT EV supply equipment terminates RPT and transfers to shutdown stage, displaying a relevant alarm or error information, if any.

**AA.6.4 Bidirectional power transfer control process**

**AA.6.4.1 Bidirectional power transfer states**

Table AA.23 defines the BPT states of the BPT EV supply equipment. The BPT states show physical status of the BPT EV supply equipment. The BPT EV supply equipment and the EV can exchange their state through the signal communication and the digital communication.

**Table AA.23 – BPT states of BPT EV supply equipment**

State		EV connected	EV disconnection device	BPT possible	Description
BDC-A	Un-mated	No	Open	No	EV un-mated
BDC-B1	Initialization	Yes	Open	No	EV connected / not ready for FPT or RPT / communication not established / connector unlatched or latched / EV disconnection device open
BDC-B2		Yes	Open	No	EV connected / not ready for FPT or RPT / communication established / connector unlatched or latched / EV disconnection device open
BDC-B3		Yes	Open	No	EV connected / not ready for FPT or RPT / communication established / connector latched / EV disconnection device open / other supplemental processes not completed

State		EV connected	EV disconnection device	BPT possible	Description
BDC-C	Energy transfer	Yes	Close	Yes	EV connected / ready for FPT or RPT / communication established / connector latched / EV disconnection device close / other supplemental processes completed
BDC-D		Yes	Close	Yes	EV connected / ready for FPT or RPT / indoor ventilation required / communication established / connector latched / EV disconnection device close / other supplemental processes completed
BDC-B'1	Shutdown	Yes	Close	Yes	EV connected / FPT or RPT finished / communication maintained / connector latched / EV disconnection device close
BDC-B'2		Yes	Open	No	EV connected / FPT or RPT finished / communication maintained / connector latched / EV disconnection device open / other supplemental processes completed
BDC-B'3		Yes	Open	No	EV connected / FPT or RPT finished / communication maintained / connector unlatched or latched / EV disconnection device open
BDC-B'4		Yes	Open	No	EV connected / FPT or RPT finished / communication finished / connector unlatched or latched / EV disconnection device open
BDC-E	Error	Yes	Open	No	BPT EV supply equipment un-mated from the EV / BPT EV supply equipment disconnected from the supply network, BPT EV supply equipment loss of supply network power or a short-circuit between the control pilot and the protective conductor
BDC-F	Malfunction	Yes	Open	No	Other BPT EV supply equipment problem
NOTE The control pilot functions can be achieved using PWM pilot control as described in IEC 61851-1 or any other system that provides the same results.					

#### AA.6.4.2 Bidirectional power transfer control process and state

Table AA.24 defines the BPT control process of the BPT EV supply equipment. For FPT control process, see AA.4.1.

**Table AA.24 – BPT control process of BPT EV supply equipment**

BPT control stage (process)		State	High level action <sup>a</sup>
Initialization	Handshaking	BDC-A	EV un-mated
		BDC-B1	Vehicle connector mated
		BDC-B1	Wake up of the SECC and EVCC
		BDC-B1	Communication setup
		BDC-B1 → BDC-B2	Communication established, parameters exchanged, and compatibility check successfully completed
	Energy transfer preparation	BDC-B2 → BDC-B3	Vehicle connector latched
		BDC-B3	Insulation resistance check for DC power line
Energy transfer	BDC-C or BDC-D	EV disconnection device closed	
	BDC-C or BDC-D	Pre-charge	
	BDC-C or BDC-D	FPT by current demand (CCM) or RPT by the maximum available current of the battery system (for MCC, see AA.6.4.3)	
	BDC-C or BDC-D	FPT by voltage demand (CVM)	
	BDC-C or BDC-D → BDC-B'1	Current suppression	
	BDC-C or BDC-D	Renegotiate parameter limits (optional)	
Shutdown	BDC-B'1	Zero current confirmed	
	BDC-B'1 → BDC-B'2	Welding detection (by the EV, optional)	
	BDC-B'2	EV disconnection device open	
	BDC-B'2	Side B voltage verification	
	BDC-B'3	Vehicle connector may be unlatched	
	BDC-B'4	End of FPT/RPT at communication level	
	BDC-A	Vehicle connector unmated	
<sup>a</sup> The order of actions does not refer to the procedure of BPT control process.			

### AA.6.4.3 Current control during reverse power transfer

In this process, the EV continues to send the maximum available current value of RPT current or the minimum allowable voltage to the BPT EV supply equipment throughout the RPT process. The following algorithms should be used.

MCC (maximum current control)

- The BPT EV supply equipment can regulate the drawn current using MCC under both EV constraints and supply network needs.
- The BPT EV supply equipment should receive the maximum available current value the EV communicated (the maximum limit), throughout the RPT control process.
- The BPT EV supply equipment should set the control target based on the supply network requirements and regulate the RPT current to less than or equal to the maximum limit.
- The BPT EV supply equipment should regulate the RPT current responding to the change of the maximum limit of the EV, if the maximum limit drops to a value less than the supply network requirement.

### AA.6.4.4 Bidirectional power transfer flow diagram

The BPT process of system A shall conform to the flow diagram as shown in Figure AA.12. Figure AA.13 gives the BPT sequence diagram under normal conditions.

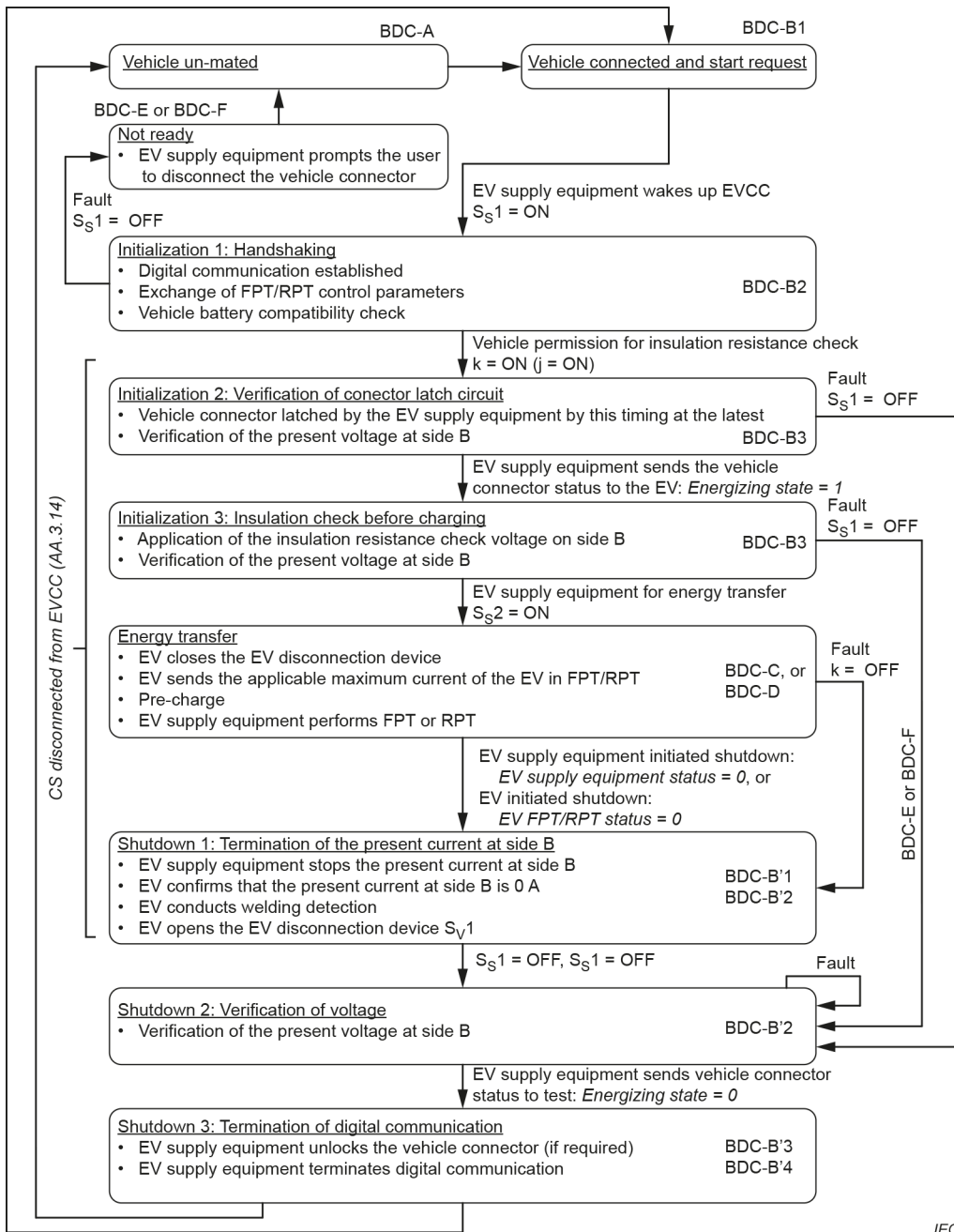

IEC

NOTE *Italic* means the parameters exchanged via digital communication as defined in IEC 61851-24:2023, Annex A.

**Figure AA.12 – Flow diagram for bidirectional power transfer**

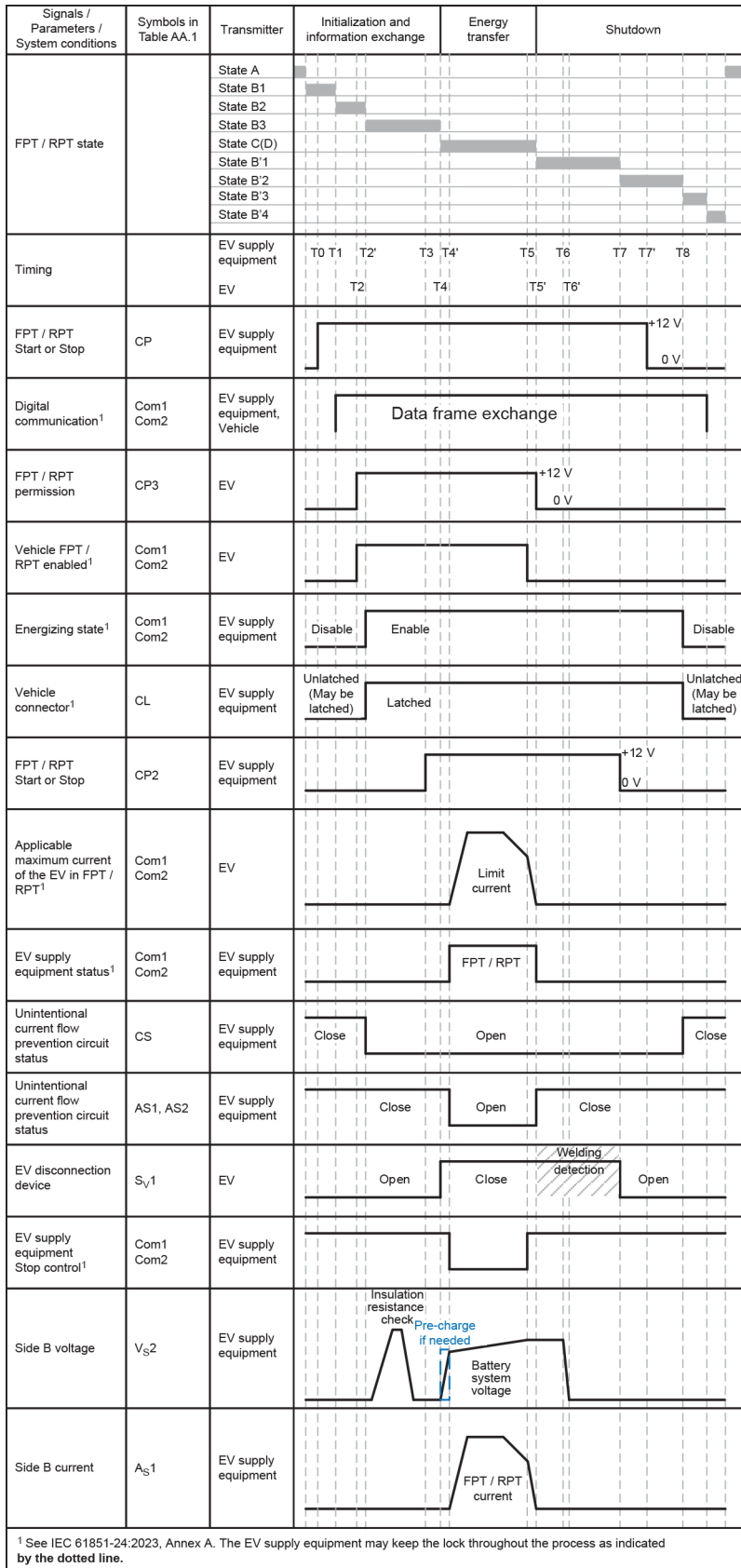

IEC

Figure AA.13 – Sequence diagram for bidirectional power transfer

## AA.7 Optional functions

### AA.7.1 General

The EV supply equipment may have some optional functions, for example, dynamic control in which the applicable maximum current of the EV supply equipment at side B communicated to an EV is dynamically controlled during the communication session.

### AA.7.2 Compatibility check

The EV supply equipment shall satisfy the following requirements in the FPT state of initialization 1:

- notify the EV that the EV supply equipment is compatible with each optional function as defined in IEC 61851-24:2023, Annex A;
- check that the EV is compatible with each optional function.

Each optional function shall be performed only if both the EV supply equipment and the EV are compatible with the optional function.

### AA.7.3 Dynamic control

The EV supply equipment shall satisfy the following requirements in the energy transfer stage under normal operation:

- change the applicable maximum current of the EV supply equipment at side B, digital message parameter defined in IEC 61581-24:2023, Annex A, to a designated value between the rate limit  $\pm 20$  A/s;
- not detect any errors associated with the dynamic control during changing the applicable maximum current of the EV supply equipment at side B.

In response, the EV will change the target current of the EV to a value less than or equal to the applicable maximum current of the EV supply equipment at side B with the rate of change defined in Clause AA.5. If the applicable maximum current of the EV supply equipment at side B is increased, the EV may also increase the target current of the EV up to the target current of the EV.

The EV supply equipment shall then supply a present current at side B according to the target current of the EV (see Figure AA.14).

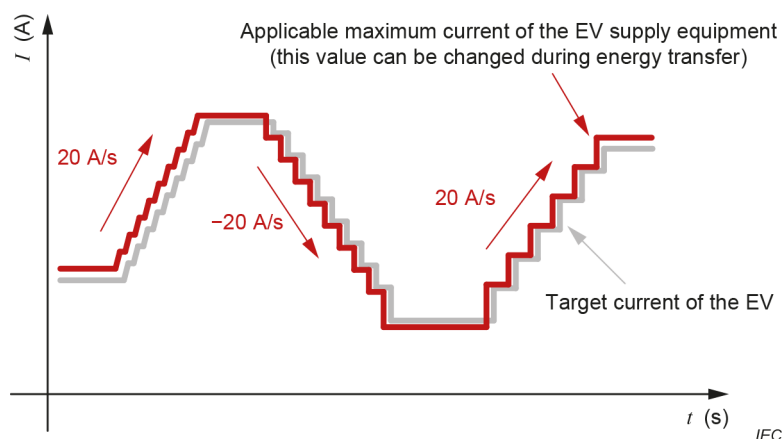

**Figure AA.14 – Transition of applicable maximum current of the EV supply equipment at side B and target current of the EV during dynamic control**

*Compliance is checked by the following test.*

- 1) *Connect the EV supply equipment to a test load with a dedicated EV simulator for the system under test. See Figure 129. The setup of the test load in Figure 132 is in Table 120.*
- 2) *Start energy transfer with the procedure specified by the EV supply equipment manufacturer.*
- 3) *Operate at OP3.*
- 4) *After confirming operation at OP3, set target operating point OP2 by external request, such as the changing the target current of the EV supply equipment at side B.*
- 5) *Start recording digital communication between the EV supply equipment and the EV.*
- 6) *Confirm that the descending rate of the applicable maximum current of the EV supply equipment at side B is  $\leq 20$  A/s.*
- 7) *After confirming operation at OP2, set target operating point OP3 by external request, such as changing the target current of the EV supply equipment at side B.*
- 8) *Confirm that the increasing rate of the applicable maximum current of the EV supply equipment at side B is  $\leq 20$  A/s.*

*In case of a voltage dip, see IEC 61851-21-2:2018, Table 3, for the operation of the EV supply equipment.*

#### **AA.7.4 High-current control**

High-current control is a means of communication between a system A EV supply equipment and an EV capable of present current at side B of  $> 200$  A DC and  $\leq 400$  A DC by using a dedicated set of digital communication messages. System A EV supply equipment capable of a present current at side B of  $> 200$  A DC under normal operation shall implement the high-current control function and use the appropriate messages according to IEC 61851-24:2023, Annex A, for digital communication with the EV implementing this function.

#### **AA.7.5 High-voltage control**

High-voltage control is a means of communication between a system A EV supply equipment and an EV capable of a present voltage at side B of  $> 500$  V DC and  $\leq 1\,000$  V DC by using a dedicated set of digital communication messages. System A EV supply equipment capable of a present voltage at side B of  $> 500$  V DC under normal operation shall implement the high-voltage control function and use the appropriate messages according to IEC 61851-24:2023, Annex A, for digital communication with the EV implementing this function.

### **AA.8 Compliance test for user-initiated shutdown**

This test shall evaluate the behaviour of the EV supply equipment in case that the communication session is terminated by user-initiated shutdown, according to the requirements in 6.3.1.110.

*The test shall be performed according to the following procedure.*

- 1) *Connect the EV supply equipment to a test load with a dedicated EV simulator for the system under test. See Figure 129. The setup of the test load in Figure 132 is in Table 120.*
- 2) *Start energy transfer with the procedure specified by the EV supply equipment manufacturer.*
- 3) *Confirm that  $V_{T-8}$  is at the rated maximum voltage of the EV supply equipment at side B.*
- 4) *Stop energy transfer by the method specified by the EV supply equipment manufacturer, for example, pressing the stop button.*
- 5) *Check that the EV supply equipment stops energy transfer without displaying any alarm or error information.*
- 6) *Confirm that  $V_{T-8}$  is  $\leq 30$  V DC.*

## AA.9 Specific requirement for energy transfer with thermal management system

The EV supply equipment shall provide one of the protection cases in Table AA.25 for protection against over-temperature of DC contact assembly of the vehicle connector and side B cable assembly according to the side B current range of EV supply equipment. Table AA.26 provides the requirements of each measure in Table AA.25.

**Table AA.25 – Selection of protection measures against over-temperature**

Side B current range	Protection case	Required measures (see Table AA.26)			
		a	b	c	d
0 A to 200 A	A	R	NR	R	NR
0 A to 200 A	B1	NR	R	R	NR
0 A to 200 A	B2	NR	R <sup>a</sup>	NR	R
0 A to 400 A	C1	R	NR	NR	R
0 A to 400 A	D1	NR	R	R	NR
0 A to 400 A	D2	NR	R <sup>a</sup>	NR	R

**Key**

R Required (mandatory)

NR Not required

R<sup>a</sup> Requirement "b" may be omitted if a side B cable assembly is also protected concurrently by the protective means of the vehicle coupler (requirement "d")

**Table AA.26 – Protection measures against over-temperature**

Type	Protection measures
a	A side B cable assembly having a rated current more than or equal to the rated maximum current of the EV supply equipment at side B shall be used.
b	By using either monitoring or estimating the surface temperature of the side B cable assembly, the present current at side B shall be limited or stopped to prevent an over-temperature. For the limitation of the present current at side B, the dynamic control function defined in AA.7.3 shall be applied.
c	A vehicle connector having a rated current (specified by each vehicle connector manufacturer) more than or equal to the rated maximum current of the EV supply equipment at side B shall be used.
d	By monitoring the temperature of both the DC+ and DC– contacts of the vehicle connector, with a temperature sensor or an equivalent means <sup>1</sup> , the present current at side B shall be reduced or stopped to prevent an over-temperature. For the limitation of the present current at side B, the dynamic control function defined in AA.7.3 shall be applied.

<sup>1</sup> Example of an equivalent means: a vehicle connector with a function to open the latch circuit (for example, temperature fuse, relay) in case the contact temperature is more than the design limit value.

## Annex BB (normative)

### EV supply equipment of system B

#### BB.1 General

Annex BB shows the specification of the EV supply equipment of system B, using the dedicated vehicle coupler of configuration BB of IEC 62196-3 or IEC TS 62196-3-1.

System B EV supply equipment shall be designed for the rated maximum voltage of the EV supply equipment at side B  $\leq 950$  V.

#### BB.2 Circuit diagrams

##### BB.2.1 Circuit diagram

Figure BB.1 shows the circuit diagram of a system B EV supply equipment for mode 4. Switch  $S_{S5}$  is optional and is used for energy saving.  $S_{S5}$  shall be closed when the vehicle connector is mated. During the whole communication session, the SECC should detect and control the states of  $S_{S1}$  and  $S_{S2}$ , while the EVCC should detect and control  $S_{V1}$ .

A type I EV supply equipment is an EV supply equipment with CCM and CVM, and  $I_{EVSE\_CPM}$  is equal to  $I_{EVSE\_Max}$ . Type II EV supply equipment is an EV supply equipment with CCM, CVM and CPM, and  $I_{EVSE\_CPM}$  is not equal to  $I_{EVSE\_Max}$ .

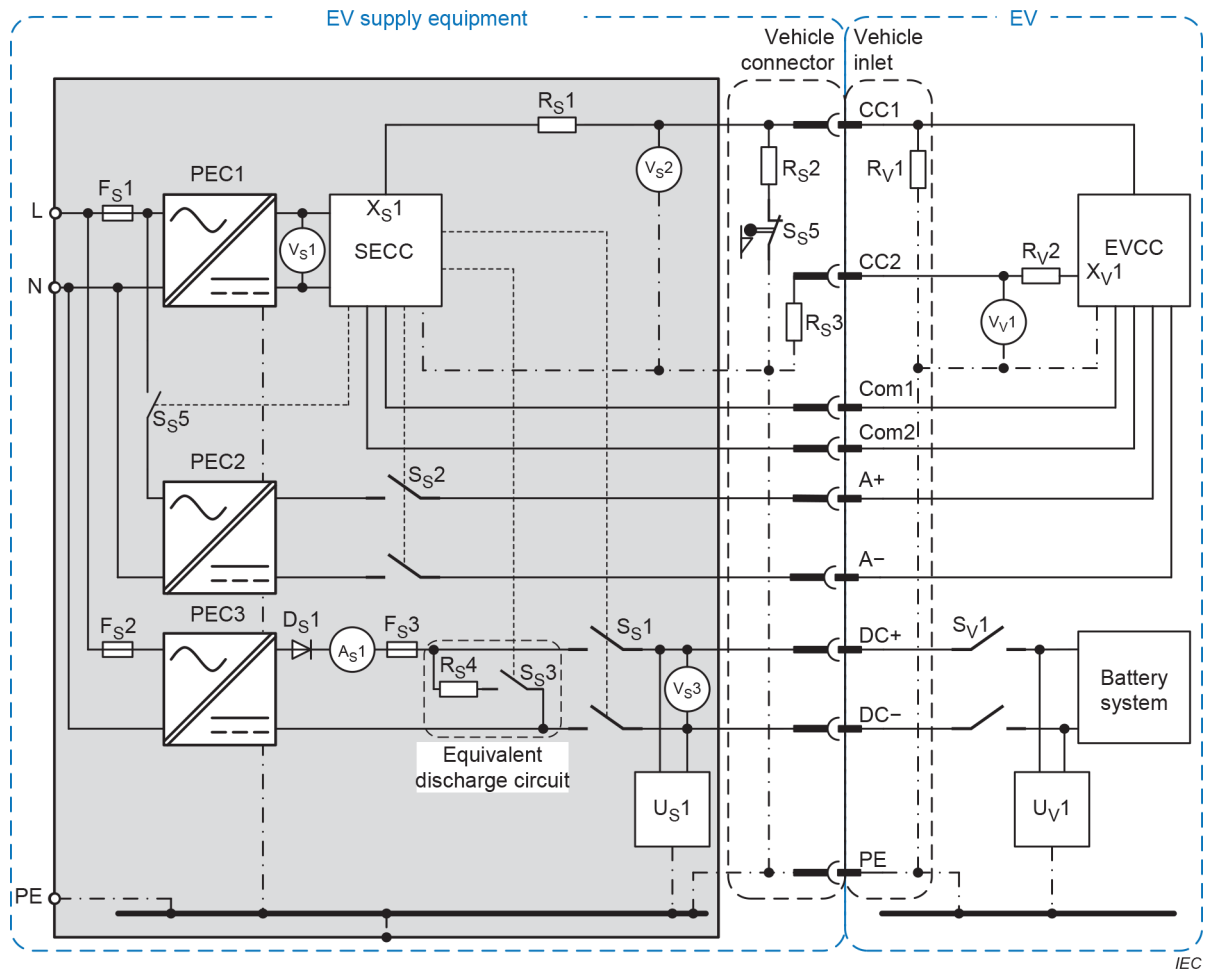

### Key

L1, N	AC or DC supply network	$D_S$	diode in the EV supply equipment
PE	protective conductor contact	$S_S$	switch or relay in the EV supply equipment
CC1, CC2	control pilot conductor contacts of system B	$S_V$	switch or relay in the EV
Com1, Com2	digital communication conductor contacts	$A_S$	ammeter in the EV supply equipment
DC+	positive terminal of side B	$R_S$	resistor in the EV supply equipment
DC-	negative terminal of side B	$R_V$	resistor in the EV
SECC	supply equipment communication controller	$U_S$	IMD of the EV supply equipment
EVCC	electric vehicle communication controller	$U_V$	IMD of the EV
PEC	power electronic converter	$V_S$	voltmeter in the EV supply equipment
A+	positive terminal of the auxiliary side B circuit	$V_V$	voltmeter in the EV
$X_V$	voltage source in the EV	$F_S$	over-current protection device
$X_S$	voltage source in the EV supply equipment	A-	negative terminal of the auxiliary side B circuit

**Figure BB.1 – System B EV supply equipment circuit diagram**

### BB.2.2 Requirements of IMD and discharge circuit

Before closing  $S_V1$ , the EV supply equipment will perform the insulation resistance check, while the EV will be responsible for the insulation resistance check during the energy transfer stage.

The insulation resistance  $R$  shall be evaluated as follows:

- $R > (500 \Omega/V \times U)$ : the insulation shall be considered as safe;
- $(100 \Omega/V \times U) < R \leq (500 \Omega/V \times U)$ : the abnormal insulation alarm may be triggered;
- $R \leq (100 \Omega/V \times U)$ : the initialization stage shall be stopped by triggering an error shutdown.

where

$R$  is the smaller value of the insulation resistance between DC+ and the protective conductor, and the insulation resistance between DC– and the protective conductor, expressed in ohms;

$U$  is the rated maximum voltage of the EV supply equipment at side B, expressed in volts.

After the EV supply equipment performs the insulation resistance check, the present voltage at side B shall be reduced in time to avoid generating a voltage surge on the EV battery system. After energy transfer finishes, the EV supply equipment shall reduce the present voltage at side B in time to avoid an electric shock on the user.

The parameter of the discharge circuit ( $R_{S4}$ ) shall be set to ensure the present voltage at side B will be  $< 60 \text{ V DC}$  in 1 s or less.

### BB.3 Parameters of control pilot circuit

Table BB.1 shows the parameter values of the control pilot circuit for FPT.

**Table BB.1 – Parameters values of the control circuit for FPT**

Object	Parameters <sup>a</sup>	Symbol	Unit	Nominal	Max.	Min.
Requirements of EV supply equipment control unit	Equivalent resistance $R_{S1}$	$R_{S1}$	$\Omega$	1 000	1 030	970
	Voltage source	$X_{S1}$	V DC	12	12,6	11,4
	Voltage at detection point 1	$V_{S2}$ (a)	V DC	12	12,8	11,2
		$V_{S2}$ (b)	V DC	6	6,8	5,2
$V_{S2}$ (c)		V DC	4	4,8	3,2	
Requirements of vehicle connector	Equivalent resistance $R_{S2}$	$R_{S2}$	$\Omega$	1 000	1 030	970
	Equivalent resistance $R_{S3}$	$R_{S3}$	$\Omega$	1 000	1 030	970
Requirements of vehicle inlet	Equivalent resistance $R_V1$	$R_V1$	$\Omega$	1 000	1 030	970
Requirements of EV	Equivalent resistance $R_V2$	$R_V2$	$\Omega$	1 000	1 030	970
	Voltage source	$X_V1$ <sup>b</sup>	V DC	12	12,6	11,4
	Voltage at detection point 2	$V_V1$ (a) <sup>b</sup>	V DC	12	12,8	11,2
		$V_V1$ (b) <sup>b</sup>	V DC	6	6,8	5,2
<sup>a</sup> The accuracy shall be maintained under applicable environmental conditions and service life. <sup>b</sup> It can be defined by the EV manufacturer.						

## BB.4 Forward power transfer control process under normal condition

### BB.4.1 Side B regulation

The accuracy of the measured current and measured voltage at side B of system B shall be between the following values:

- voltage measurement:  $\pm 0,5 \%$ ;
- current measurement:
  - $\pm 1 \%$  of the present current at side B if the present current at side B is  $> 30 \text{ A DC}$ ;
  - $\pm 0,3 \text{ A}$  if the present current at side B is  $\leq 30 \text{ A DC}$ .

### BB.4.2 Measuring current and voltage

The present voltage and present current at side B shall be continuously monitored and communicated in 1 s or less, including measurement delay and digital communication (CAN) transmission delay.

The accuracy of the measured current and voltage at side B reported via digital communication of system B shall be between the following values:

- measured current at side B:  $\pm 1,5 \%$  of present current at side B + 1 A ;
- measured voltage at side B  $< 500 \text{ V}$ :  $\pm 5 \text{ V}$ ;
- measured voltage at side B  $> 500 \text{ V}$ :  $\pm 1 \%$  of the rated maximum voltage of the EV supply equipment at side B.

Compliance is checked by the following test.

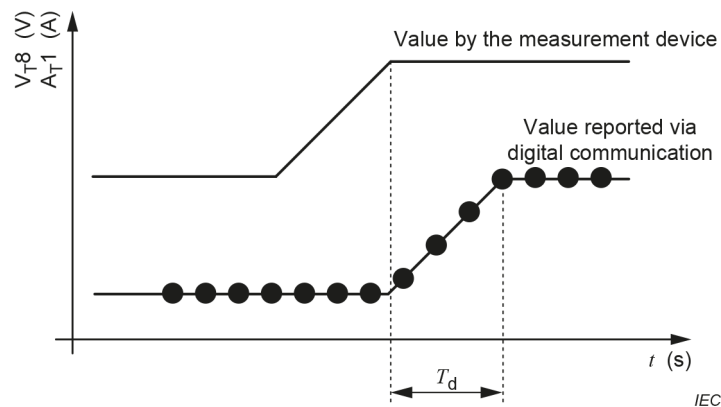

#### Key

$T_d$  Measurement delay and digital communication transmission delay

**Figure BB.2 – Representation of delay between the measures current and voltage at side B and the digital communication transmission for system B**

#### Test 1:

- 1) Connect the EV supply equipment to a test load with a dedicated EV simulator for the system under test, under normal operation. See Figure 130. The setup of the test load in Figure 132 for system B is in Table 120.
- 2) Start energy transfer with the procedure specified by the EV supply equipment manufacturer.

- 3) Operate at OP3 (for a type I EV supply equipment) or OP4 (for a type II EV supply equipment)
- 4) After confirming operation at OP3 (for a type I EV supply equipment) or OP4 (for a type II EV supply equipment), the EV simulator shall set the target current of the EV to  $I_{EVSE\_max} - 20$  A via digital communication.
- 5) Measure  $A_{T1}$  and digital communication.
- 6) Confirm that the measurement delay and digital communication transmission delay is 1 s or less. See Figure BB.2.

Test 2:

- 1) Connect the EV supply equipment to a test load with a dedicated EV simulator for the system under test, under normal operation. See Figure 130. The setup of the test load in Figure 132 for system B is in Table 120.
- 2) Start energy transfer with the procedure specified by the EV supply equipment manufacturer.
- 3) Operate at OP1.
- 4) After confirming operation at OP1, EV simulator shall set the target current of the EV to  $I_{EVSE\_min} + 20$  A via digital communication.
- 5) Measure  $A_{T1}$  and digital communication.
- 6) Confirm that the measurement delay and digital communication transmission delay is 1 s or less. See Figure BB.2.

Test 3:

- 1) Connect the EV supply equipment to a test load with a dedicated EV simulator for the system under test, under normal operation. See Figure 130. The setup of the test load in Figure 132 for system B is in Table 120.
- 2) Start energy transfer with the procedure specified by the EV supply equipment manufacturer.
- 3) Operate at OP1.
- 4) After confirming operation at OP1, set the target voltage of the EV to  $V_{EVSE\_max}$  via digital communication.
- 5) Measure  $V_{T8}$  and digital communication.
- 6) Confirm that the measurement delay and digital communication transmission delay is 1 s or less. See Figure BB.2.

Test 4:

- 1) Connect the EV supply equipment to a test load with a dedicated EV simulator for the system under test, under normal operation. See Figure 130. The setup of the test load in Figure 132 for system B is in Table 120.
- 2) Start energy transfer with the procedure specified by the EV supply equipment manufacturer.
- 3) Operate at OP3.
- 4) After confirming operation at OP3, set the target voltage of the EV to  $V_{EVSE\_min}$  via digital communication.
- 5) Measure  $V_{T8}$  and digital communication.
- 6) Confirm that the measurement delay and digital communication transmission delay is 1 s or less. See Figure BB.2.

**BB.4.3 Vehicle coupler mating confirmation**

When the vehicle coupler is mated,  $V_S2$  measured by the EV supply equipment shall be between the range of  $V_S2(c)$  defined in Table BB.1.

When the vehicle coupler is connected,  $V_V1$  measured by the EV shall be between the range of  $V_V1(b)$  defined in Table BB.1.

*The compliance test for the vehicle coupler mating confirmation shall be performed according to the following procedure.*

- 1) *Connect the EV supply equipment to a test load with a dedicated EV simulator for the system under test. See Figure 130. The setup of the test load in Figure 132 for system B is in Table 120.*
- 2) *Confirm that the present voltage at side A is energized at the rated maximum voltage of the EV supply equipment at side A.*
- 3) *Measure  $V_T2$  and  $V_T3$ .*
- 4) *Confirm that  $V_T2$  is between the range of  $V_S2(c)$  defined in Table BB.1, and that  $V_T3$  shall be between the range of  $V_V1(b)$  defined in Table BB.1.*

**BB.4.4 Forward power transfer control sequence**

Figure BB.3 shows the FPT control sequence diagram under normal conditions.

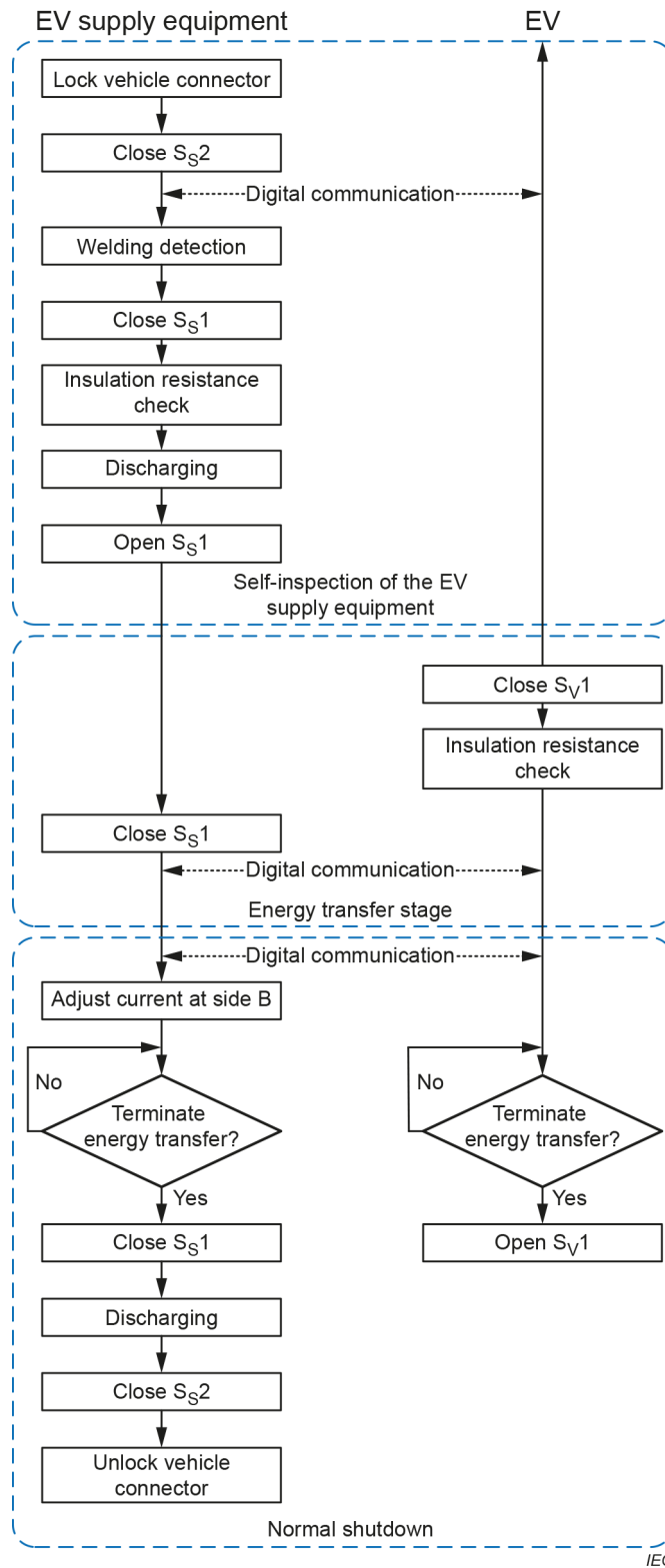

**Figure BB.3 – FPT control sequence for system B**

- a) When the EV supply equipment performs the insulation detection, the present voltage at side B for insulation detection shall be the lower one between the rated maximum voltage of the EV and the rated maximum voltage of the EV supply equipment at side B.

- b) The pre-charge shall be carried out only when
- the variation of the EV battery system voltage from the pre-charge request message is between  $\pm 5\%$ , and
  - the EV battery system voltage is between the rated maximum voltage of the EV supply equipment at side B and rated minimum voltage of the EV supply equipment at side B.

#### **BB.4.5 Normal shutdown**

The EV supply equipment shall comply with the following procedure for normal shutdown.

- a) EV normal shutdown
- 1) The EV supply equipment shall send "Charger stopping command" by digital communication if it receives "Vehicle stopping command" without a failure code, and the EV supply equipment shall reduce the present current at side B to  $\leq 5$  A DC with the current descending speed of  $\geq 100$  A/s.
  - 2) Switch  $S_{S1}$  of the EV supply equipment shall be open and the EV supply equipment shall bleed the present voltage at side B. Switch  $S_{S2}$  of the EV supply equipment shall be open until digital communication is finished.
- b) User-initiated shutdown
- 1) When a stop energy transfer condition is reached or the user stops energy transfer by interacting with the HMI, the EV supply equipment shall send "Charger stopping command" by digital communication to notify the EV of start of a normal shutdown process.
  - 2) The EV supply equipment shall reduce the present current at side B to  $\leq 5$  A DC with the current descending speed of  $\geq 100$  A/s.
  - 3) Switch  $S_{S1}$  of the EV supply equipment shall be open and the EV supply equipment shall bleed the present voltage at side B. Switch  $S_{S2}$  of the EV supply equipment shall be open until digital communication is finished.

*The compliance test for normal shutdown shall be performed according to the following procedure.*

- 1) *Connect the EV supply equipment to a test load with a dedicated EV simulator for the system under test, under normal operation. See Figure 130. The setup of the test load in Figure 132 for system B is shown in Table 120.*
- 2) *Start energy transfer with the procedure specified by the EV supply equipment manufacturer.*
- 3) *Confirm that  $V_{T8}$  is at the rated maximum voltage of the EV supply equipment at side B.*
- 4) *Select stopping methods: for example, pre-setting energy transfer conditions before energy transfer or stop energy transfer by interacting with the HMI.*
- 5) *Check that the EV supply equipment stops energy transfer without displaying any alarm or error information.*
- 6) *Confirm that  $V_{T8}$  is  $\leq 60$  V DC.*

### **BB.5 Safety requirements under failure mode**

#### **BB.5.1 Error shutdown and emergency shutdown**

If one of the errors specified in Table BB.2 occurs, the EV supply equipment shall perform an error shutdown according to 6.3.1.113.3. Recommended specification for the response performance is also given in Table BB.2.

**Table BB.2 – Error shutdown times and criteria**

Fault	Detection time of EV supply equipment after the start of the fault	Shutdown trigger by	Side B after the start of the fault		Condition to unlatch the vehicle connector
Digital communication timeout (6.3.1.5, BB.5.4)	9,5 s	EV supply equipment	10 s	The EV supply equipment shall reduce: <ul style="list-style-type: none"> <li>– present current at side B &lt; 5 A DC;</li> <li>– present voltage at side B ≤ 60 V DC between DC+ and DC–, DC+/DC– and protective conductor</li> </ul>	After the shutdown process is completed and the present voltage at side B between DC+ and DC– ≤ 60 V DC
Overvoltage fault (101.1.7, 6.3.1.106, BB.5.6)	500 ms	EV supply equipment	1 s		
Overcurrent protection of the DC connection-Secondary overcurrent protection (BB.5.10)	1 s	EV supply equipment	1,5 s		
Load dump (101.1.7, BB.5.7)	500 ms	EV supply equipment	1 s		
Fault to protective conductor (BB.5.11)	1 s after receiving the stop energy transfer message from the EV	EV	1,5 s		

When one of the following errors in Table BB.3 occurs, the system B EV supply equipment shall perform an emergency shutdown according to 6.3.1.113.4. Recommended specifications for the response performance are also given in Table BB.3.

**Table BB.3 – Emergency shutdown times and criteria**

Fault	Detection time of EV supply equipment after the start of the fault	Shutdown trigger by	Side B after the start of the fault	Condition to unlatch vehicle connector
Terminate energy transfer due to EV supply equipment fault (6.3.1.5, 9.101, BB.5.2)	70 ms	EV supply equipment	The present current at side B shall be ≤ 5 A DC in 100 ms or less.  The present voltage at side B shall be ≤ 60 V DC in 570 ms or less.	After shutdown process is completed and the present voltage at side B between DC+ and DC– ≤ 60 V DC
Terminate energy transfer due to an EV fault (BB.5.3)	20 ms after receiving the stop energy transfer message from the EV	EV	After receiving the stop energy transfer message from the EV:  The present current at side B shall be ≤ 5 A DC in 50 ms or less.  The present voltage at side B shall be ≤ 60 V DC in 520 ms or less.	
Loss of electrical continuity of the control pilot (BB.5.5)	20 ms	EV supply equipment	The present current at side B shall be ≤ 5 A DC in 50 ms or less.  The present voltage at side B shall be ≤ 60 V DC in 520 ms or less.	

Fault	Detection time of EV supply equipment after the start of the fault	Shutdown trigger by	Side B after the start of the fault	Condition to unlatch vehicle connector
Overvoltage fault (BB.5.6)	10 ms	EV supply equipment	The present current at side B shall be $\leq 5$ A DC in 40 ms or less. The present voltage at side B shall be $\leq 60$ V DC in 510 ms or less.	
Overcurrent protection of the DC connection- Primary overcurrent protection: (BB.5.10)	500 ms	EV supply equipment	The present current at side B shall be $\leq 5$ A in 530 ms or less. The present voltage at side B shall be $\leq 60$ V DC in 1 s or less.	
Loss of electrical continuity of the protective conductor (6.3.1.2)	70 ms	EV supply equipment	The present current at side B shall be $\leq 5$ A in 100 ms or less. The present voltage at side B shall be $\leq 60$ V DC in 570 ms or less.	
Short-circuit protection of the DC connection (13.101, BB.5.8)	1 s	EV supply equipment	The present current at side B shall be $\leq 5$ A in 1,03 s or less. The present voltage at side B shall be $\leq 60$ V DC in 1,5 s or less.	

### BB.5.2 Terminate energy transfer due to an EV supply equipment fault

For any conditions of failure of the EV supply equipment during energy transfer, specified by the EV supply equipment manufacturer, in addition to what is covered in this document, the EV supply equipment shall trigger an emergency shutdown (see 6.3.1.113.3) in 70 ms or less, and send the stop energy transfer message to the EV.

*Compliance is checked by the following test.*

*The test shall be performed according to the following procedure.*

- 1) *Connect the EV supply equipment to a test load with a dedicated EV simulator for the system under test, under normal operation. See Figure 130. The setup of the test load in Figure 132 for system B is shown in Table 120.*
- 2) *The present voltage at side A is at the rated maximum voltage of the EV supply equipment at side A.*
- 3) *Simulate every failure specified by the EV supply equipment manufacturer, one at a time during this test. Check that the EV supply equipment triggers and performs an emergency shutdown, displaying a relevant alarm or error information, if any.*
- 4) *Check that the maximum shutdown time of the present current at side B  $t_{shutdown}$  is as follows:*

$$t_{shutdown} = t_{trigger} + t_{perform} = 100 \text{ ms after the EV supply equipment fails}$$

where

$$t_{trigger} = 70 \text{ ms};$$

$$t_{perform} = 30 \text{ ms}.$$

*After  $t_{shutdown} = 100$  ms,  $A_T1$  shall be  $\leq 5$  A DC.*

- 5) Check that, 570 ms after the occurrence of the fault of the EV supply equipment,  $V_{T8}$  is  $\leq 60$  V DC.

### BB.5.3 Terminate energy transfer due to an EV fault

If the EV fails during energy transfer, the EVCC will periodically send the stop energy transfer message with the fault reason to the EV supply equipment. The EV supply equipment shall trigger an emergency shutdown (see 6.3.1.113.3) in 20 ms or less after receiving the stop energy transfer message from the EV and send the stop energy transfer message to the EV.

Compliance is checked by the following test.

The test shall be performed according to the following procedure.

- 1) Connect the EV supply equipment to a test load with a dedicated EV simulator for the system under test, under normal operation. See Figure 130. The setup of the test load in Figure 132 for system B is shown in Table 120.
- 2) The present voltage at side A is at the rated maximum voltage of the EV supply equipment at side A.
- 3) Simulate opening  $S_{V1}$  during energy transfer and send the stop energy transfer message to the EV supply equipment. Check that the EV supply equipment triggers and performs an emergency shutdown, displaying a relevant alarm or error information, if any.
- 4) Check that the voltage overshoot is according to the requirements of the load dump in BB.5.7.
- 5) Check that the maximum shutdown time of the present current at side B  $t_{shutdown}$  is as follows:

$$t_{shutdown} = t_{trigger} + t_{perform} = 50 \text{ ms after receiving the stop energy transfer message from the EV}$$

where

$$t_{trigger} = 20 \text{ ms};$$

$$t_{perform} = 30 \text{ ms}.$$

After  $t_{shutdown} = 50$  ms,  $A_{T1}$  shall be  $\leq 5$  A DC.

- 6) Check that, 520 ms after receiving the stop energy transfer message from the EV,  $V_{T8}$  is  $\leq 60$  V DC.

### BB.5.4 Digital communication timeout

If the SECC encounters a digital communication timeout during the communication session, the EV supply equipment shall trigger an error shutdown (see 6.3.1.113.3) in 9,5 s or less and open  $S_S1$ .

Compliance is checked by the following test.

The test shall be performed according to the following procedure.

- 1) Connect the EV supply equipment to a test load with a dedicated EV simulator for the system under test, under normal operation. See Figure 130. The setup of the test load in Figure 132 for system B is shown in Table 120.
- 2) The present voltage at side A is at the rated maximum voltage of the EV supply equipment at side A.
- 3) Simulate a loss of electrical continuity, a short-circuit between the digital communication conductors (Com1 and Com2) or a digital communication timeout. Check that the EV supply equipment triggers and performs an error shutdown, displaying a relevant alarm or error information, if any. Check that  $S_S1$  is opened in 10 s or less after the occurrence of the fault.

- 4) Check that the maximum shutdown time of the present current at side B  $t_{shutdown}$  is as follows:

$t_{shutdown} = t_{trigger} + t_{perform} = 10 \text{ s}$  after losing electrical continuity of the digital communication conductor(s) or a digital communication timeout

where

$t_{trigger} = 9,5 \text{ s};$

$t_{perform} = 500 \text{ ms}.$

After  $t_{shutdown} = 10 \text{ s}$ ,  $A_T1$  shall be  $\leq 5 \text{ A DC}$ .

- 5) Check that, 10 s after the occurrence of the fault,  $V_{T8} \leq 60 \text{ V DC}$ .
- 6) Check that  $S_S1$  opens in 10 s or less after the occurrence of the fault.

### BB.5.5 Loss of electrical continuity of the control pilot

When an error in the control pilot CC1 occurs during the communication session such that the measured voltage of detecting point 1 is beyond the range of  $V_S2$  defined in Table BB.1, or switch  $S_S5$  is opened, the EV supply equipment shall trigger an emergency shutdown in 20 ms or less, and send the stop energy transfer message to the EV.

*Compliance is checked by the following test.*

*The test shall be performed according to the following procedure.*

- 1) Connect the EV supply equipment to a test load with a dedicated EV simulator for system B under normal operation. See Figure 130. The setup of the test load in Figure 132 for system B is shown in Table 120.
- 2) The present voltage at side A is at the rated maximum voltage of the EV supply equipment at side A.
- 3) Simulate turning off  $X_S1$  or opening  $S_S5$ . Check that the EV supply equipment triggers and performs an emergency shutdown, displaying a relevant alarm or error information, if any.
- 4) Check that the maximum shutdown time of the present current at side B  $t_{shutdown}$  is as follows:

$t_{shutdown} = t_{trigger} + t_{perform} = 50 \text{ ms}$  after the EV supply equipment fails

with

$t_{trigger} = 20 \text{ ms};$

$t_{perform} = 30 \text{ ms}.$

After  $t_{shutdown} = 50 \text{ ms}$ ,  $A_T1$  shall be  $\leq 5 \text{ A DC}$ .

- 5) Check that, 520 ms after the occurrence of the fault,  $V_{T8} \leq 60 \text{ V DC}$ .

### BB.5.6 Overvoltage fault

The EV supply equipment shall detect the present voltage at side B as shown in Table BB.4 by hardware means (for example, a dedicated overvoltage measurement circuit) to disable the PEC and transfer to emergency shutdown in 10 ms or less. According to the rated minimum voltage of the EV supply equipment at side B and the rated maximum voltage of the EV supply equipment at side B, the setpoints shall be determined by digital communication based on rated maximum voltage of the EV sent during the initialization phase.

**Table BB.4 – EV simulator voltage ranges emergency shutdown reaction test**

Rated maximum voltage of the EV at the initialization phase $U$	Value of $U_{T4}$ during energy transfer $V$	Value of $U_{T4}$ for emergency shutdown reaction $V$
$U \leq 500 V$	Minimum (rated maximum voltage of the EV supply equipment at side B, 450 V)	550
$500 V < U \leq 750 V$	Minimum (rated maximum voltage of the EV supply equipment at side B, 700 V)	825
$750 V < U \leq 850 V$	-	935
$850 V < U \leq 1\ 000 V$	Rated maximum voltage of the EV supply equipment at side B	1 100

Compliance is checked by the following test.

The test shall be performed according to the following procedure.

- 1) Connect the EV supply equipment to a test load with a dedicated EV simulator for the system under test, under CCM operation. See Figure 130. The setup of the test load in Figure 132 for system B is shown in Table 120.
- 2) The present voltage at side A is at the rated maximum voltage of the EV supply equipment at side A.
- 3) Simulate an EV with a rated maximum voltage of the EV at the initialization phase  $\leq 500 V$ . Adjust  $U_{T4}$  during energy transfer to the rated maximum voltage of the EV supply equipment at side B or 450 V DC, whichever is less. Then, increase  $U_{T4}$  to 550 V DC. Check that the EV supply equipment triggers and performs an emergency shutdown, displaying a relevant alarm or error information if any.
- 4) Check that the maximum shutdown time of the present current at side B  $t_{\text{shutdown}}$  is as follows:

$$t_{\text{shutdown}} = t_{\text{trigger}} + t_{\text{perform}} = 40 \text{ ms after the occurrence of overvoltage fault}$$

where

$$t_{\text{trigger}} = 10 \text{ ms};$$

$$t_{\text{perform}} = 30 \text{ ms}.$$

After  $t_{\text{shutdown}} = 40 \text{ ms}$ ,  $A_{T1}$  shall be  $\leq 5 \text{ A DC}$ .

- 5) Check that, 510 ms after the occurrence of overvoltage,  $V_{T8}$  is  $\leq 60 \text{ V DC}$ .
- 6) Repeat this test from step 1) to step 5) with EV simulator rated maximum voltage of the EV according to Table BB.4.

### BB.5.7 Load dump

In any case of load dump, the voltage overshoot shall be less than 110 % of the last target voltage of the EV before the load dump, or less than the target voltage of the EV + 50 V DC, whichever is more.

Compliance is checked by the following test.

The test shall be performed according to the following procedure.

- 1) Connect the EV supply equipment to a test load with a dedicated EV simulator for the system under test, under normal operation. See Figure 130. The setup of the test load in Figure 132 for system B is in Table 120.
- 2) Measure  $V_{T8}$  continuously.
- 3) Start energy transfer with the procedure specified by the EV supply equipment manufacturer.
- 4) Confirm that  $V_{T8}$  is at the rated maximum voltage of the EV supply equipment at side B, and that the EV supply equipment is operating at the operating point OP4 in Figure 133.
- 5) Open  $S_{T17}$  and  $S_{T18}$ .
- 6) Check that the EV supply equipment triggers and performs an emergency shutdown, displaying a relevant alarm or error information, if any.
- 7) Check the parameters for the requirement through 4) to 6):

*The maximum voltage of  $V_{T8} \leq \max(110 \% \times \text{target voltage of the EV, target voltage of the EV} + 50 \text{ V DC})$*

NOTE The transient voltage lasting for  $\leq 10$  ms, which can appear after the load dump, can be ignored.

#### **BB.5.8 Short-circuit protection of side B**

The EV supply equipment shall protect side B and the side B cable assembly against short-circuits. The short-circuit protection device shall meet a normal melting rating of  $\leq 500\,000$  A<sup>2</sup>s.

*Compliance is checked by design review to verify normal melting rating.*

The EV supply equipment shall trigger an emergency shutdown in 1 s or less after the short-circuit is detected at side B.

Specific requirements on the timing criteria for the emergency shutdowns are given in Table BB.3 (see BB.5.1).

*Compliance is checked by the following test.*

- 1) Connect the EV supply equipment to a test load with a dedicated EV simulator for the system under test, under normal operation. See Figure 130. The setup of the test load in Figure 132 for system B is shown in Table 120.
- 2) Open  $S_{T7}$ . Set  $L_{T1} = 0$  mH and  $R_{T2} = 100$  m $\Omega$ .
- 3) The present voltage at side A is at the rated maximum voltage of the EV supply equipment at side A.
- 4) Start energy transfer with the procedure specified by the EV supply equipment manufacturer.
- 5) The EV supply equipment is operated at OP3.
- 6) Close  $S_{T8}$ .
- 7) Check that the maximum shutdown time of side B  $t_{shutdown}$  follows a) and b):

$$t_{shutdown} = t_{trigger} + t_{perform} = \text{after the occurrence of short-circuit fault}$$

where

$$t_{trigger} = 1 \text{ s.}$$

- a)  $A_{T1}: \leq 5$  A DC in  $t_{shutdown} = 1,030$  s or less.
- b)  $V_{T8}: \leq 60$  V DC in  $t_{shutdown} = 1,5$  s or less.

- 8) Check that  $V_{S1}$  is not interrupted until the energy transfer sequence is completed and the vehicle coupler is safely unlatched. See 6.3.1.108.

#### **BB.5.9 Lock and latch monitoring for vehicle connector**

According to 6.3.1.103, a vehicle connector used shall be latched on a vehicle inlet if the voltage is  $> 60$  V DC.

*Compliance is checked by the following test.*

- 1) Connect the EV supply equipment to a test load with a dedicated EV simulator for the system under test, under normal operation. See Figure 130. The setup of the test load in Figure 132 for system B is shown in Table 120.
- 2) Check if the electronic lock status corresponds to the latch position.
- 3) Before energy transfer, simulate the abnormal conditions by pressing the switch  $S_{S5}$  or un-mating the vehicle connector, check that the EV supply equipment does not start energy transfer.
- 4) During energy transfer, check that the electronic lock shall be effectively locked and cannot be unlocked.
- 5) At the end of energy transfer, if  $V_{T8}$  is  $> 60$  V DC, check that the electronic lock remains locked.

#### **BB.5.10 Overcurrent protection of side B**

The EV supply equipment shall provide overcurrent protection to protect side A and side B.

- Emergency overcurrent protection

The EV supply equipment shall trigger an emergency shutdown in 0,5 s or less after one or both of the following conditions are continuously fulfilled for 0,5 s:

- the present current at side B is more than 120 % of the applicable maximum current of the EV supply equipment at side B;
- during energy transfer, the present voltage at side B is less than 80 % of the applicable minimum voltage of the EV supply equipment at side B.

- Error overcurrent protection

If the following conditions are continuously fulfilled for a duration of 1 s during energy transfer, the EV supply equipment shall trigger an error shutdown:

- present current at side B  $\geq 30$  A DC: present current at side B is more than 102 % of the target current of the EV;
- present current at side B  $< 30$  A DC: present current at side B is more than the target current of the EV by 0,6 A DC or more.

*Compliance is checked by design review to verify that a function is provided.*

#### **BB.5.11 Insulation fault monitoring**

In the case of a fault between side B live parts (DC+/DC–) to protective conductor, the EV supply equipment shall trigger an error shutdown in 1 s or less after receiving the stop energy transfer message from the EV.

Specific requirements on the timing criteria for the error shutdowns are given in Table BB.3 (see BB.5.1).

*Compliance is checked by the following test.*

The test shall be performed according to the following procedure.

- 1) Connect the EV supply equipment to a test load with a dedicated EV simulator for the system under test, under normal operation. See Figure 130. The setup of the test load in Figure 132 for system B is shown in Table 120.
- 2) The present voltage at side A is at the rated maximum voltage of the EV supply equipment at side A.
- 3) Start energy transfer with the procedure specified by the EV supply equipment manufacturer.
- 4) The EV supply equipment operates at OP3.
- 5) The EV simulator sends the EV the stop energy transfer message with the fault between DC+/DC– to the protective conductor.
- 6) Check that the EV supply equipment triggers an error shutdown.
- 7) Check that the maximum shutdown time of side B  $t_{shutdown}$  follows a) and b):

$t_{shutdown} = t_{trigger} + t_{perform}$  = after the occurrence of the fault between DC+/DC– to protective conductor

where

$t_{trigger} = 1 \text{ s};$

$t_{perform} = 0,5 \text{ s}.$

- a)  $A_{T1} \leq 5 \text{ A DC}$  in  $t_{shutdown} = 1,5 \text{ s}$  or less.
  - b)  $V_{T8} \leq 60 \text{ V DC}$  in  $t_{shutdown} = 1,5 \text{ s}$  or less.
- 8) Check that  $V_{S1}$  is not interrupted until the energy transfer sequence is completed and the vehicle coupler is safely unlatched. See 6.3.1.108.

## BB.6 Timing sequence diagram of forward power transfer

Figure BB.4 shows the sequence diagram of FPT.

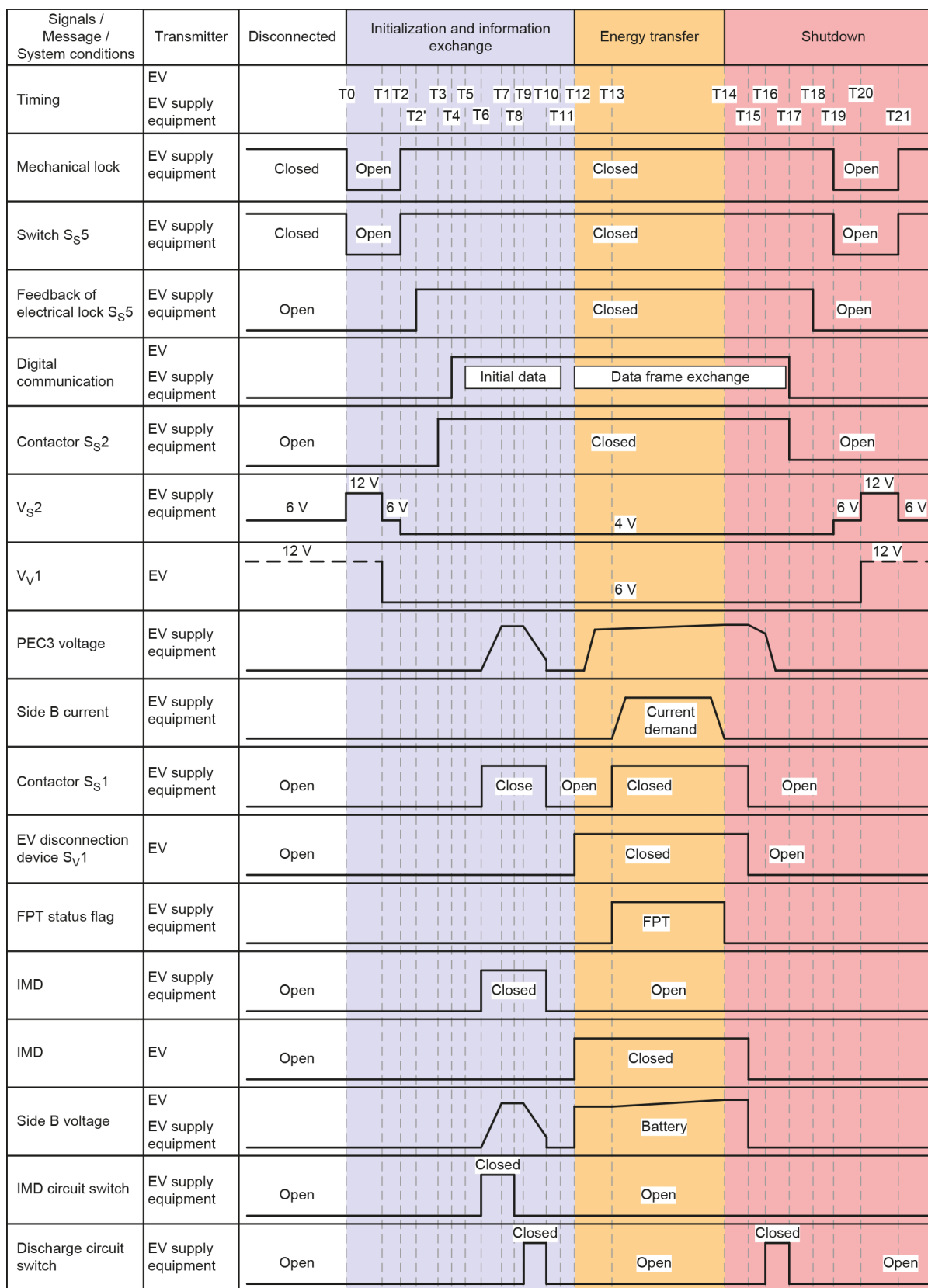

IEC

Figure BB.4 – Timing sequence diagram of FPT

### BB.7 Side B current regulation in CCM

Table BB.5 shows the test load setup for the compliance test in 101.1.2.1.

**Table BB.5 – Setup of the test load for side B current regulation in CCM**

Switches					Circuit parameter setup
S <sub>T</sub> 17, S <sub>T</sub> 18	S <sub>T</sub> 19	S <sub>T</sub> 20	S <sub>T</sub> 21	S <sub>T</sub> 22	
Closed	Closed	Open	Closed	Open	L <sub>T</sub> : 0 mH R <sub>T</sub> 10: 0 Ω R <sub>T</sub> 11: Variable U <sub>T</sub> 4: Controlled voltage source C <sub>T</sub> 5: 5 600 μF (different case depended)

In 101.1.2.1 4), record  $I_{EV\_target}$  and  $A_{T1}$  at the following operating points (see Figure BB.5):

- OP1, OP2, OP3, OP5 (for a type I EV supply equipment);
- OP1, OP2, OP3, OP4, OP5 (for a type II EV supply equipment).

NOTE 1 In the following countries, the function of CPM can be specified by each EV supply equipment manufacturer and is not mandatory: CN.

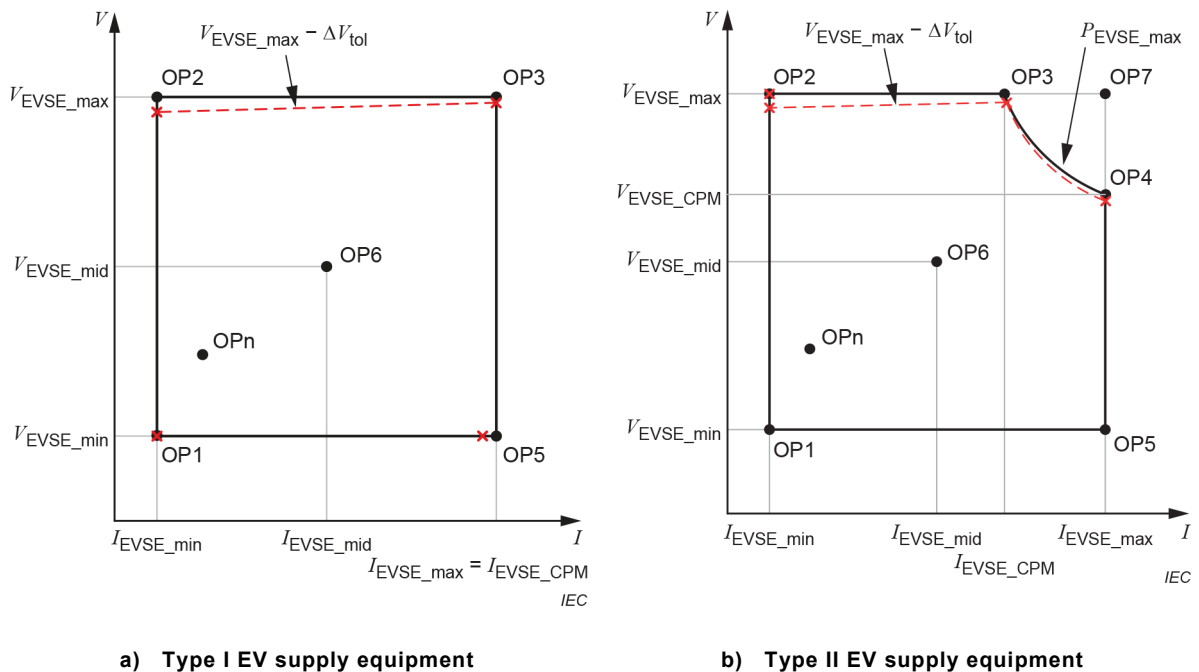

#### Key

- operating point
- × test point

**Figure BB.5 – Operating points and test points for side B current regulation in CCM**

NOTE 2  $\Delta V_{tol}$  is needed in order to achieve side B current regulation (CCM).

Recommended steps for sweeping the voltage and current at side B of the EV supply equipment are shown in Table BB.6.

**Table BB.6 – Recommended steps for minimum side B current regulation in CCM**

Step	Action	Description
1	Set $V_{EV\_target} = V_{EVSE\_max}$	Communicate: Target voltage of the EV = rated maximum voltage of the EV supply equipment at side B
2	Set $U_{T4} = V_{EVSE\_min} - I_{EV\_target} \times (R_{T10} + R_{T11});$ $I_{EV\_target} = I_{EVSE\_min}$ to check OP1	Communicate: Target current of the EV = greater value of 5 A and rated minimum current of the EV supply equipment at side B
3	Set $U_{T4} = V_{EVSE\_min} - I_{EV\_target} \times (R_{T10} + R_{T11});$ $I_{EV\_target} = I_{EVSE\ rated\ max}$ to check OP5	Communicate: Target current of the EV = rated continuous current of the EV supply equipment at side B
4	Set $U_{T4} = (V_{EVSE\_max} - \Delta V_{tol}) - I_{EV\_target} \times (R_{T10} + R_{T11});$ $I_{EV\_target} = I_{EVSE\_min}$ to check OP2. $\Delta V_{tol} = 0,02 \times V_{EVSE\_max} + 5\ V$ derived from 101.1.2.2 and 101.1.6	Communicate: Target current of the EV = rated continuous current of the EV supply equipment at side B
5	Set $U_{T4} = (V_{EVSE\_max} - \Delta V_{tol}) - I_{EV\_target} \times (R_{T10} + R_{T11})$ $I_{EV\_target} = I_{EVSE\_max}$ to check OP3  For a type I EV supply equipment: $I_{EV\_target} = I_{EVSE\_max}$ to check OP3 For a type II EV supply equipment: $I_{EV\_target} = I_{EVSE\ CPM}$ to check OP3	Communicate: For a type I charger: Target current of the EV = rated continuous current of the EV supply equipment at side B For a type II charger: Target current of the EV = $I_{EVSE\ CPM} = P_{EVSE\_max} / V_{EVSE\_max}$
For a type II EV supply equipment, also go to step 6.		
6	Set $U_{T4} = (P_{EVSE\_max} / I_{EVSE\_max} - \Delta V_{tol}) - I_{EV\_target} \times (R_{T10} + R_{T11});$ $I_{EV\_target} = I_{EVSE\_max}$ , to check OP4.	Communicate: Target current of the EV = rated continuous current of the EV supply equipment at side B

### BB.8 Insulation resistance check before energy transfer

During the cable-check phase before energy transfer, asymmetrical and symmetrical insulation tests shall be performed.

*Compliance is checked by the following test.*

*Asymmetrical test:*

*Case 1:*

- 1) *Connect the EV supply equipment to a test load with a dedicated EV simulator for the system under test, under normal operation. See Figure 130. The setup of the test load in Figure 132 for system B is in Table 120.*
- 2) *Before the insulation resistance check, only close switch  $S_{T11}$  and set  $R_{T5} \leq (100\ \Omega/V \times U)$ .*
- 3) *Start a communication session with the procedure specified by the EV supply equipment manufacturer.*

- 4) Check that the  $V_{T8}$  for the cable-check phase shall be the lower one between the rated maximum voltage of the EV and the rated maximum voltage of the EV supply equipment at side B for 1 s or more, and that the EV supply equipment triggers and performs an error shutdown.
- 5) After  $V_{T8}$  is  $< 60$  V DC in 1 s or less, open  $S_S1$ .
- 6) Repeat steps 2) to 5) for the case in which only close switch  $S_{T13}$  and set  $R_{T6} \leq (100 \Omega/V \times U)$  in step 2).

where  $U$  is the rated maximum voltage of the EV supply equipment at side B.

#### Case 2:

- 1) Connect the EV supply equipment to a test load with a dedicated EV simulator for the system under test, under normal operation. See Figure 130. The setup of the test load in Figure 132 for system B is in Table 120.
- 2) Before the insulation resistance check, only close switch  $S_{T11}$  and set  $(100 \Omega/V \times U) < R_{T5} \leq (500 \Omega/V \times U)$ .
- 3) Start a communication session with the procedure specified by the EV supply equipment manufacturer.
- 4) Check that  $V_{T8}$  for the cable-check shall be the lower one between the rated maximum voltage of the EV and the rated maximum voltage of the EV supply equipment at side B for 1 s or more.
- 5) The EV supply equipment shall not trigger an error shutdown. The abnormal insulation alarm may be triggered.
- 6) Repeat steps 2) to 5) for the case in which only close switch  $S_{T13}$  and set  $(100 \Omega/V \times U) < R_{T6} \leq (500 \Omega/V \times U)$  in step 2).

where  $U$  is the rated maximum voltage of the EV supply equipment at side B.

#### Symmetrical test:

##### Case 1:

- 1) Connect the EV supply equipment to a test load with a dedicated EV simulator for the system under test, under normal operation. See Figure 130. The setup of the test load in Figure 132 for system B is in Table 120.
- 2) Before the insulation resistance check, close  $S_{T11}$  and  $S_{T13}$ , and set  $R_{T5} = R_{T6} \leq (100 \Omega/V \times U)$ .
- 3) Start a communication session with the procedure specified by the EV supply equipment manufacturer.
- 4) Check that  $V_{T8}$  for the cable-check shall be the lower one between the rated maximum voltage of the EV and the rated maximum voltage of the EV supply equipment at side B for 1 s or more.
- 5) The EV supply equipment shall trigger an error shutdown.
- 6) After  $V_{T8}$  is  $< 60$  V DC in 1 s or less, open  $S_S1$ .

where  $U$  is the rated maximum voltage of the EV supply equipment at side B.

##### Case 2:

- 1) Connect the EV supply equipment to a test load with a dedicated EV simulator for the system under test, under normal operation. See Figure 130. The setup of the test load in Figure 132 for system B is in Table 120.

- 2) Before the insulation resistance check, close switch  $S_{T11}$  and  $S_{T13}$ , and set  $(100 \Omega/V \times U) < R_{T5} = R_{T6} \leq (500 \Omega/V \times U)$ .
- 3) Start a communication session with the procedure specified by the EV supply equipment manufacturer.
- 4) Check that  $V_{T8}$  for the cable-check shall be the lower one between the rated maximum voltage of the EV and the rated maximum voltage of the EV supply equipment at side B for 1 s or more.
- 5) The EV supply equipment shall not trigger an error shutdown. The abnormal insulation alarm may be triggered.

where  $U$  is the rated maximum voltage of the EV supply equipment at side B.

### BB.9 Side B voltage regulation in CVM

Compliance for the requirements in 101.1.2.2 is checked by the following test.

The test shall be performed according to the following procedure.

- 1) Connect the EV supply equipment to a test load with a dedicated EV simulator for the system under test. See Figure 130. The setup of the test load in Figure 132 for system B is shown in Table 120, or the test load can also be a resistive load.
- 2) Measure  $V_{T8}$  and  $A_{T1}$  continuously.
- 3) Start energy transfer with the procedure specified by the EV supply equipment manufacturer.
- 4) Record  $U_{EV\_target}$  and  $V_{T8}$  at the following operating points:
  - OP1, OP2, OP3, OP5 (for a type I EV supply equipment);
  - OP1, OP2, OP3, OP4, OP5 (for a type II EV supply equipment).

Recommended steps for sweeping the present voltage and current of the EV supply equipment at side B are shown in Table BB.7.

**Table BB.7 – Recommended steps for side B voltage regulation in CVM**

	Action	Description
Test setup	<ol style="list-style-type: none"> <li>1) Connect the EV supply equipment to a test load with a dedicated EV simulator for the system under test, under normal operation. See Figure 130. The setup of the test load in Figure 132 for system B is shown in Table 120.</li> <li>2) The present voltage at side A is at the rated maximum voltage of the EV supply equipment at side A.</li> <li>3) <math>I_{Target}</math> and <math>V_{Target}</math> are the target current and target voltage of the EV (or EV simulator) sent to the EV supply equipment through digital communication.</li> </ol>	
Case 1	Step 1: Set $U_{T4} = V_{EVSE\_min} - I_{EVSE\_min} \times (R_{T10} + R_{T11})$ ; Step 2: Set $I_{Target} = I_{EVSE\_max}$ and $V_{Target} = V_{EVSE\_min}$ ; Step 3: Adjust $U_{T4}$ to make $A_{T6} = I_{EVSE\_min} + \Delta I_{tol}$ ; Step 4: To check the side B voltage regulation under OP1.	Communicate:  Target current of the EV $I_{Target}$ = rated boost current of the EV supply equipment at side B.  Target voltage of the EV $V_{Target}$ = rated minimum voltage of the EV supply equipment at side B.

	Action	Description
Case 2	<p>Step 1: Set <math>U_{T4} = V_{EVSE\_max} - I_{EVSE\_min} \times (R_{T10} + R_{T11})</math>;</p> <p>Step 2: Set <math>I_{Target} = I_{EVSE\_max}</math> and <math>V_{Target} = V_{EVSE\_max}</math>;</p> <p>Step 3: Adjust <math>U_{T4}</math> to make <math>A_{T6} = I_{EVSE\_min} + \Delta I_{tol}</math>;</p> <p>Step 4: To check the side B voltage regulation under OP2.</p>	<p>Communicate:</p> <p>Target current of the EV <math>I_{Target}</math> = rated boost current of the EV supply equipment at side B.</p> <p>Target voltage of the EV <math>V_{Target}</math> = rated maximum voltage of the EV supply equipment at side B.</p>
Case 3	<p>Step 1:</p> <p>For a type I EV supply equipment: Set <math>U_{T4} = V_{EVSE\_max} - I_{EVSE\_max} \times (R_{T10} + R_{T11})</math>;</p> <p>For a type II EV supply equipment: Set <math>U_{T4} = V_{EVSE\_max} - I_{EVSE\_cpm} \times (R_{T10} + R_{T11})</math>;</p> <p>Step 2: Set <math>I_{Target} = I_{EVSE\_max}</math> and <math>V_{Target} = V_{EVSE\_max}</math>;</p> <p>Step 3:</p> <p>For a type I EV supply equipment: Adjust <math>U_{T4}</math> to make <math>A_{T6} = I_{EVSE\_max} - \Delta I_{tol} - 1</math> A;</p> <p>For a type II EV supply equipment: Adjust <math>U_{T4}</math> to make <math>A_{T6} = I_{EVSE\_cpm} - \Delta I_{tol} - 1</math> A;</p> <p>Step 4: To check the side B voltage regulation under OP3.</p>	<p>Communicate:</p> <p>Target current of the EV <math>I_{Target}</math> = rated boost current of the EV supply equipment at side B.</p> <p>Target voltage of the EV <math>V_{Target}</math> = rated maximum voltage of the EV supply equipment at side B.</p>
Case 4	<p>Step 1: Set <math>U_{T4} = V_{EVSE\_min} - I_{EVSE\_max} \times (R_{T10} + R_{T11})</math>;</p> <p>Step 2: Set <math>I_{Target} = I_{EVSE\_max}</math> and <math>V_{Target} = V_{EVSE\_min}</math>;</p> <p>Step 3: Adjust <math>U_{T4}</math> to make <math>A_{T6} = I_{EVSE\_max} - \Delta I_{tol} - 1</math> A;</p> <p>Step 4: To check the side B voltage regulation under OP5.</p>	<p>Communicate:</p> <p>Target current of the EV <math>I_{Target}</math> = rated boost current of the EV supply equipment at side B.</p> <p>Target voltage of the EV <math>V_{Target}</math> = rated minimum voltage of the EV supply equipment at side B.</p>
For a type II EV supply equipment, also do case 5.		
Case 5	<p>Step 1: For a type II EV supply equipment: Set <math>U_{T4} = P_{EVSE\_max} / I_{EVSE\_max} - I_{EVSE\_max} \times (R_{T10} + R_{T11})</math>;</p> <p>Step 2: Set <math>I_{Target} = I_{EVSE\_max}</math> and <math>V_{Target} = P_{EVSE\_max} / I_{EVSE\_max}</math>;</p> <p>Step 3: For a type II EV supply equipment: Adjust <math>U_{T4}</math> to make <math>A_{T6} = I_{EVSE\_max} - \Delta I_{tol} - 1</math> A;</p> <p>Step 4: To check the side B voltage regulation under OP4.</p>	<p>Communicate:</p> <p>For a type II EV supply equipment: Target current of the EV <math>I_{Target}</math> = rated boost current of the EV supply equipment at side B.</p> <p>Target voltage of the EV <math>V_{Target}</math> &lt; rated maximum voltage of the EV supply equipment at side B.</p>
<p><math>\Delta I_{tol} = 1</math> % of the present current at side B if the present current at side B is &gt; 30 A DC.</p> <p><math>\Delta I_{tol} = 0,3</math> A DC if the present current at side B is <math>\leq 30</math> A DC, derived from BB.4.1.</p> <p><math>\Delta V_{tol} = 0,02 \times V_{EVSE\_max} + 5</math> V DC derived from 101.1.2.2 and 101.1.6.</p>		

- 5) During the voltage/current sweep (transition from one OP to another OP) and for each operating point, check that the difference between the measured voltage values and the target value sent by the EV simulator are between the limits specified in 101.1.2.2 (see Figure BB.6).

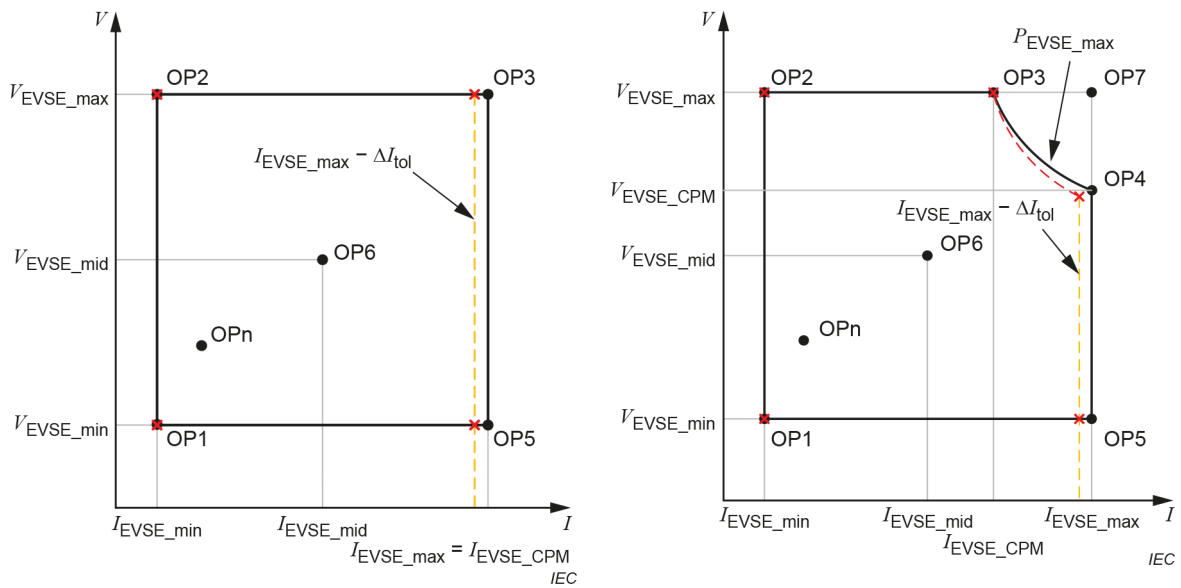

a) Type I EV supply equipment

b) Type II EV supply equipment

**Key**

- operating point
- × test point

**Figure BB.6 – Operating points and test points for side B voltage regulation in CVM**

NOTE  $\Delta I_{tol}$  is needed in order to achieve side B voltage regulation (CVM).

**BB.10 Periodic and random deviation (voltage ripple at side B in CVM)**

Compliance to 101.1.6 is checked by the following test.

- 1) The EV supply equipment is connected to a test load with a dedicated EV simulator for the system under test, under normal operation. See Figure 130. The setup of the test load in Figure 132 for system B is shown in Table 120.
- 2) The EV supply equipment shall operate at the proper operating points and the test case shall be executed in single steps as indicated below. In each step, the EV shall issue a current request as given in 3).
- 3) Request  $OP_n$  with following restrictions to  $I_{EV\_target}$  and  $V_{EV\_target}$ :
  - $OP1, OP2, OP3, OP5$  (for a type I EV supply equipment);
  - $OP1, OP2, OP3, OP4, OP5$  (for a type II EV supply equipment).
- 4) Measure the EV supply equipment present voltage ripple at side B under each operating point.
- 5) Oscilloscope requirements: frequency bandwidth of 20 MHz, the horizontal scanning speed of 0,5 s / division.
- 6) Present voltage ripple at side B shall be less than or equal to the limits specified in 101.1.6.

**BB.11 Energy transfer control mode**

**BB.11.1 Definition**

The energy transfer control modes CCM, CVM and CPM are shown in Figure BB.7.

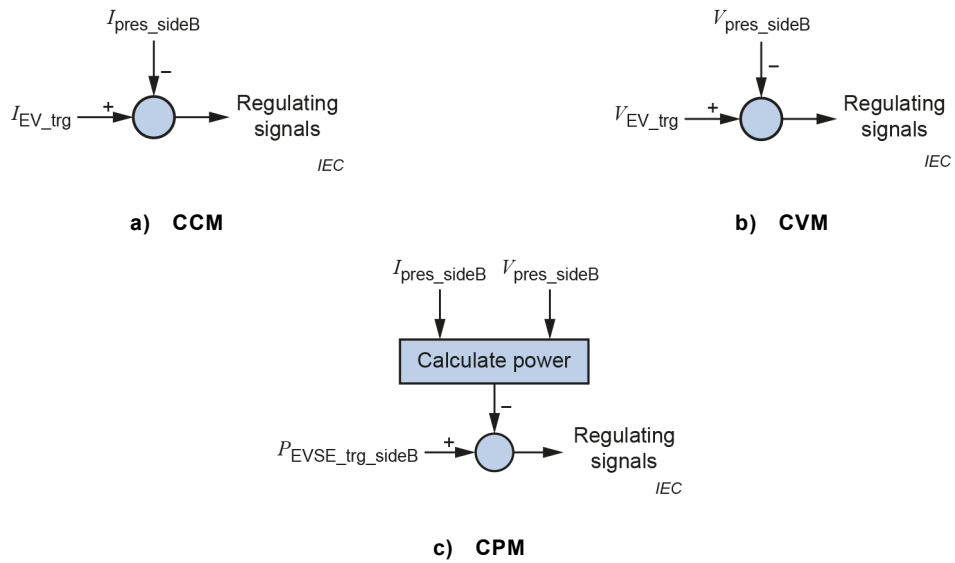
**Key**

$I_{\text{pres\_sideB}}$ , $V_{\text{pres\_sideB}}$	present current/voltage at side B
$I_{\text{EV\_trg}}$	target current of the EV or other sources like thermal control unit inside the EV supply equipment
$V_{\text{EV\_trg}}$	target voltage of the EV
$P_{\text{EVSE\_trg\_sideB}}$	target power of the EV supply equipment at side B
regulating signals	signal that is used to adjust the side B value (it is usually the PWM signal to drive the MOSFET or IGBT)

**Figure BB.7 – Definition of CCM, CVM and CPM****BB.11.2 Typical forward power transfer process**

Figure BB.8 shows a typical FPT process with different energy transfer modes.

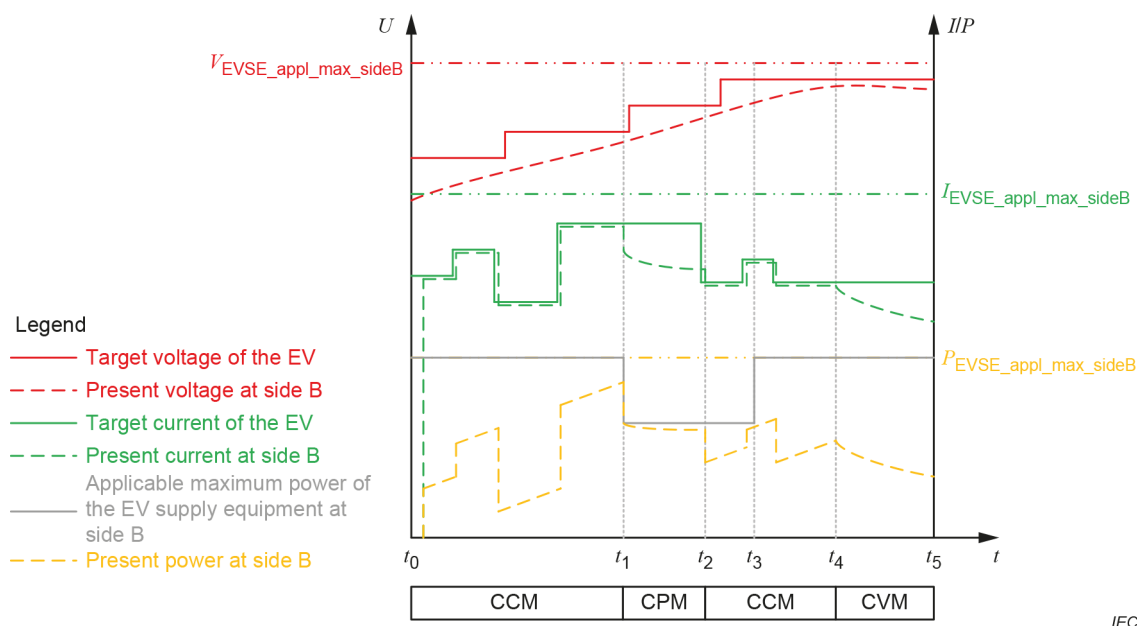

Timestamps	$t_0$ to $t_1$	$t_1$ to $t_2$	$t_2$ to $t_3$	$t_3$ to $t_4$	$t_4$ to $t_5$
<b>Behaviour</b>	The present current at side B follows the target current of the EV	The present current at side B is less than the target current of the EV because the applicable maximum power of the EV supply equipment at side B is limited by the supply network	The present current at side B follows the target current of the EV because the target current of the EV is less than the calculated current of the applicable maximum power of the EV supply equipment at side B	The present current at side B follows the target current of the EV	The present current at side B is controlled by the target voltage of the EV
<b>Mode requested by the EV</b>	CCM	CCM	CCM	CCM	CVM
<b>Mode of the EV supply equipment</b>	CCM	CPM	CCM	CCM	CVM

Figure BB.8 – Typical FTP process

### BB.12 Standby mode

The EV supply equipment may support a standby mode to minimize the power consumption. The EV supply equipment shall turn off the PECs, and control units, which are not used to support the wake-up function. The standby power consumption of the EV supply equipment shall be  $\leq N \times 50 \text{ W}$ , where  $N$  is the number of the vehicle couplers of the EV supply equipment at side B which can provide power simultaneously.

*Compliance is checked by the following test.*

*The test shall be performed according to the following procedure.*

- 1) The present voltage at side A is at the rated maximum voltage of the EV supply equipment at side A.*
- 2) The EV supply equipment is un-mated from the EV and without a user operating the EV supply equipment. Energy transfer is under standby mode.*
- 3) Measure that the side A power consumption of the EV supply equipment shall be  $\leq N \times 50 \text{ W}$ .*
- 4) Simulate that the vehicle connector of the EV supply equipment is mated into the vehicle inlet or an interaction with the HMI. The EV supply equipment shall wake up.*

Sleep mode for system B is under consideration.

### **BB.13 Smart charging**

If the EV supply equipment supports smart charging, the EV supply equipment shall adjust the present current at side B according to the demand response of the supply network.

### **BB.14 Minimum cross-sectional area of the protective conductor**

The minimum cross-sectional area of the protective conductor shall be 16 mm<sup>2</sup>.

## Annex CC (normative)

### EV supply equipment of system C

#### CC.1 General

Annex CC provides specific requirements for EV supply equipment for use with system C. System C is a mode 4 EV supply equipment. The rated maximum voltage of the EV supply equipment at side B shall be limited to  $\leq 1\,000$  V DC, dependent on the components of the system.

The vehicle couplers shall comply with one of the configurations listed in Table CC.1.

**Table CC.1 – Vehicle couplers for system C**

No.	Vehicle couplers for system C
a)	Configuration EE according to IEC 62196-3 or IEC TS 62196-3-1
b)	Configuration FF according to IEC 62196-3 or IEC TS 62196-3-1
NOTE Configuration CC and configuration DD are not covered by IEC 62196-3:2014 <sup>8</sup> and IEC 62196-3:2022.	

#### CC.2 Circuit diagrams

##### CC.2.1 General

The general definitions and functions of the proximity pilot (PP) and control pilot (CP) signals/contacts are according to IEC 61851-1 (including detailed resistor definitions in IEC 61851-1:2017, Table B.1 and Table B.2) and SAE J1772. A control pilot oscillator duty cycle of 5 % shall be used according to IEC 61851-1:2017, Annex A.

Digital communications between the EV supply equipment and the EV shall comply with IEC 61851-24.

The physical layer for digital communication shall comply with ISO 15118-3. Digital communication uses the control pilot conductor and the protective conductor. Contact assignments of the different vehicle connectors are specified in IEC 62196-3:2022.

The EV supply equipment shall turn off its control pilot oscillator if the EV supply equipment is not ready to receive digital communication. See CC.5.2.3.2 for additional timing requirements for the control pilot oscillator.

##### CC.2.2 Circuit diagram for configuration EE

The circuit diagram of Figure CC.1 shall be used for configuration EE.

<sup>8</sup> This publication has been withdrawn.

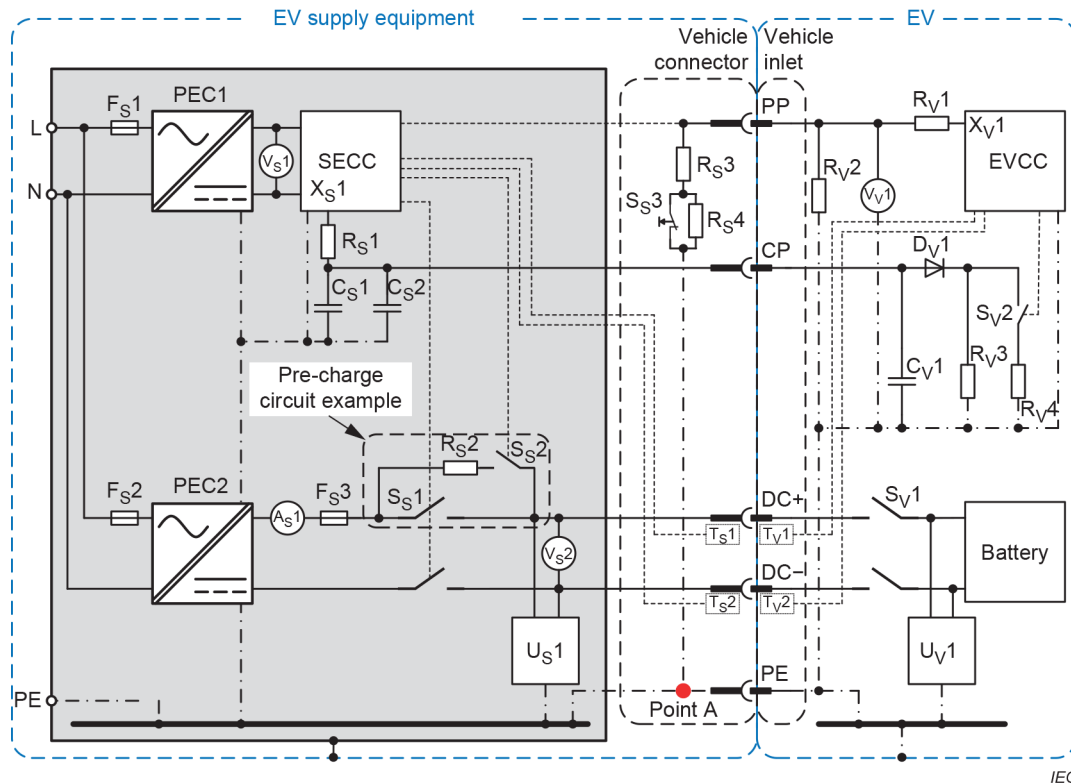

IEC

**Key**

L1, N	AC or DC supply network	$C_V$	capacitance in the EV
PE	protective conductor contact	$S_S$	switch or relay in the EV supply equipment
CP	control pilot conductor contact of system C	$S_V$	switch or relay in the EV
PP	proximity pilot conductor contacts	$A_S$	ammeter in the EV supply equipment
DC+	positive terminal of side B	$R_S$	resistor in the EV supply equipment
DC-	negative terminal of side B	$R_V$	resistor in the EV
SECC	supply equipment communication controller	$U_S$	IMD of the EV supply equipment
EVCC	electric vehicle communication controller	$U_V$	IMD of the EV
PEC1, PEC2	power electronic converter	$V_S$	voltmeter in the EV supply equipment
$X_V1$	voltage source in the EV	$V_V$	voltmeter in the EV
$X_S1$	voltage source in the EV supply equipment	$F_S$	over-current protection device in the EV supply equipment
$C_S$	capacitance in the EV supply equipment	$D_V$	diode in the EV
$T_S$	temperature sensor in the EV supply equipment	$T_V$	temperature sensor in the EV
point A	point where the proximity pilot conductor is connected to the protective conductor		

See IEC 61851-1:2017, Annex A and Annex B, for additional circuit diagrams and components.

**Figure CC.1 – Circuit diagram for a system C EV supply equipment of configuration EE**

**Table CC.2 – Component values and tolerances for configuration EE**

Component <sup>a</sup>	Symbol	Minimum value	Nominal value <sup>b</sup>	Maximum value	Unit
<b>Control pilot</b>					
Equivalent load resistance	$R_{S1}$	970	1 000	1 030	$\Omega$
Equivalent load resistance for EVs not requiring ventilation	$R_{V4}$	1 261	1 300	1 339	$\Omega$
Equivalent load resistance for EVs requiring ventilation	$R_{V4}$	261,9	270	278,1	$\Omega$
Equivalent load resistance	$R_{V3}$	2 658	2 740	2 822	$\Omega$
Voltage drop from $D_{V1}$	$D_{V1}$	0,55	0,7	0,85	V DC
EV supply equipment control pilot capacitance	$C_{S1} + C_{S2}$	300	n.a.	3 100	pF
Total equivalent EV control pilot capacitance	$C_{V1}$	n.a.	n.a.	2 400	pF
Generator open circuit positive voltage	$X_{S1}$	11,4	12	12,6	V DC
Generator open circuit negative voltage		-12,6	-12	-11,4	V DC
Frequency generator		980	1 000	1 020	Hz
Pulse width		5 % – 5 $\mu$ s	5 %	5 % + 5 $\mu$ s	-
Rise time (10 % to 90 %)		n.a.	n.a.	2	$\mu$ s
Fall time (90 % to 10 %)		n.a.	n.a.	2	$\mu$ s
Settling time to 95 % steady state		n.a.	n.a.	3	$\mu$ s
<b>Proximity pilot</b>					
Proximity pilot regulated voltage source	$X_{V1}$	4,75	5	5,25	V DC
Equivalent load resistance	$R_{V1}$	297	330	363	$\Omega$
Equivalent load resistance	$R_{V2}$	2 430	2 700	2 970	$\Omega$
Equivalent load resistance	$R_{S3}$	135	150	165	$\Omega$
Equivalent load resistance	$R_{S4}$	297	330	363	$\Omega$
<sup>a</sup> Tolerances to be maintained over the full useful life and under environmental conditions as specified by the EV supply equipment manufacturer.					
<sup>b</sup> Resistors with a tolerance of 1 % are recommended for this application. See IEC 61851-1:2017, Annex A and Annex B.					

The proximity pilot circuit shall comply with the voltages specified in Table CC.3.

**Table CC.3 – Proximity pilot voltages**

<b>Condition <sup>a</sup></b>	<b>Minimum voltage V DC</b>	<b>Average voltage V DC</b>	<b>Maximum voltage V DC</b>
Vehicle connector unmated and S <sub>S3</sub> closed/open	–0,1	0	0,1
Vehicle connector mated and S <sub>S3</sub> closed	1,23	1,51	1,82
Vehicle connector mated and S <sub>S3</sub> open	2,38	2,76	3,16

<sup>a</sup> When the vehicle connector is mated, the EV supply equipment manufacturer may interpret a proximity pilot voltage between 1,82 V DC and 2,38 V DC as S<sub>S3</sub> open or S<sub>S3</sub> closed.

**CC.2.3 Circuit diagram for configuration FF**

The circuit diagram of Figure CC.2 shall be used for configuration FF.

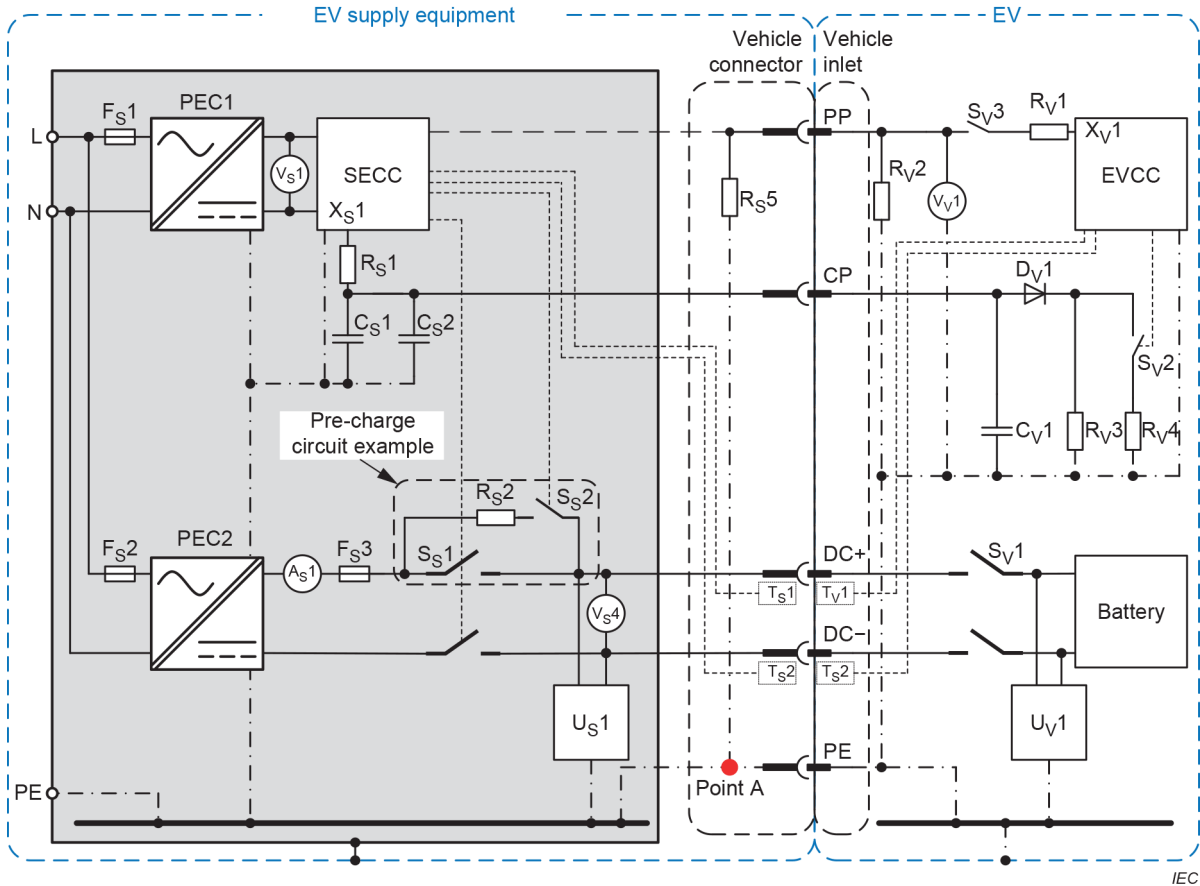

IEC

**Key**

L1, N	AC or DC supply network	$C_V$	capacitance in the EV
PE	protective conductor contact	$S_S$	switch or relay in the EV supply equipment
CP	control pilot conductor contact of system C	$S_V$	switch or relay in the EV
PP	proximity pilot conductor contacts	$A_S$	ammeter in the EV supply equipment
DC+	positive terminal of side B	$R_S$	resistor in the EV supply equipment
DC-	negative terminal of side B	$R_V$	resistor in the EV
SECC	supply equipment communication controller	$U_S$	IMD of the EV supply equipment
EVCC	electric vehicle communication controller	$U_V$	IMD of the EV
PEC1, PEC2	power electronic converter	$V_S$	voltmeter in the EV supply equipment
$X_{V1}$	voltage source in the EV	$V_V$	voltmeter in the EV
$X_{S1}$	voltage source in the EV supply equipment	$F_S$	over-current protection device in the EV supply equipment
CS	capacitance in the EV supply equipment	$D_V$	diode in the EV
$T_S$	temperature sensor in the EV supply equipment	$T_V$	temperature sensor in the EV
point A	point where the proximity pilot conductor is connected to the protective conductor		

See IEC 61851-1:2017, Annex A, Annex B and Annex C, for circuit diagrams and additional components.

**Figure CC.2 – Circuit diagram of a system C EV supply equipment of configuration FF**

**Table CC.4 – Component values and tolerances for configuration FF**

Component <sup>a</sup>	Symbol	Minimum value	Nominal value <sup>b</sup>	Maximum value	Unit
<b>Control pilot</b>					
Equivalent load resistance	$R_{S1}$	970	1 000	1 030	$\Omega$
Equivalent load resistance for EVs not requiring ventilation	$R_{V4}$	1 261	1 300	1 339	$\Omega$
Equivalent load resistance for EVs requiring ventilation	$R_{V4}$	261,9	270	278,1	$\Omega$
Equivalent load resistance	$R_{V3}$	2 658	2 740	2 822	$\Omega$
Voltage drop from $D_{V1}$	$D_{V1}$	0,55	0,7	0,85	V DC
EV supply equipment control pilot capacitance	$C_{S1} + C_{S2}$	300	n.a.	3 100	pF
Total equivalent EV control pilot capacitance	$C_{V1}$	n.a.	n.a.	2 400	pF
Generator open circuit positive voltage	$X_{S1}$	11,4	12	12,6	V DC
Generator open circuit negative voltage		-12,6	-12	-11,4	V DC
Frequency generator		980	1 000	1 020	Hz
Pulse width		5 % – 5 $\mu$ s	5 %	5 % + 5 $\mu$ s	-
Rise time (10 % to 90 %)		n.a.	n.a.	2	$\mu$ s
Fall time (90 % to 10 %)		n.a.	n.a.	2	$\mu$ s
Settling time to 95 % steady state		n.a.	n.a.	3	$\mu$ s
<b>Proximity pilot</b>					
Proximity pilot regulated voltage source <sup>c</sup>	$X_{V1}$	4,75	5	5,25	V DC
Equivalent load resistance <sup>c</sup>	$R_{V1}$	297	330	363	$\Omega$
Equivalent load resistance	$R_{S5}$	1 455	1 500	1 545	$\Omega$
Optional equivalent load resistance for the EV proximity pilot check circuit <sup>c,d</sup>	$R_{V2}$	2430	2 700 or 4 700	5 170	$\Omega$
<p><sup>a</sup> Tolerances to be maintained over the full useful life and under environmental conditions as specified by the EV supply equipment manufacturer.</p> <p><sup>b</sup> Resistors with a tolerance of 1 % are recommended for this application.</p> <p><sup>c</sup> These are recommended values. IEC 61851-1:2017, Clause B.2, does not define these values. The EV manufacturer defines these values because the PP circuit in IEC 61851-1:2017, Clause B.2, was not intended to be checked by the EV supply equipment.</p> <p><sup>d</sup> The EV manufacturer may choose 2 700 <math>\Omega</math> to use the same value for configuration EE, or alternatively 4 700 <math>\Omega</math> to improve the detection of the current coding resistor <math>R_{S5}</math> (<math>R_C</math> in IEC 61851-1:2017), according to IEC 61851-1:2017, Clause B.2.</p>					

The switch  $S_{V3}$  is optional for the EV to implement depending on its strategy to detect the loss of electrical continuity of the protective conductor (see CC.4.7).

**CC.2.4 Disabled side B**

The points in time when the EV supply equipment shall enable and disable its side B are specified in Clause CC.3.

The side B of the EV supply equipment, when disabled, shall have the equivalent electrical behaviour as the circuit in Figure CC.3, with the component limits defined in Table CC.5.

During normal shutdown, the common mode and differential mode voltages of the disabled side B shall be discharged to < 60 V DC in 2 s or less after the EV opens the EV disconnection device. See CC.3.3.

During error shutdown and emergency shutdown, the present voltage at side B discharge requirements are defined in 6.3.1.113.3 and 6.3.1.113.4, respectively.

The equivalent  $C_{S4}$  capacitance shall be limited to 1  $\mu$ F.

NOTE The limitation of  $C_{S4}$  in the disabled side B reduces the energy stored if the EV closes the EV disconnection device during welding detection.

*Compliance is checked by design review.*

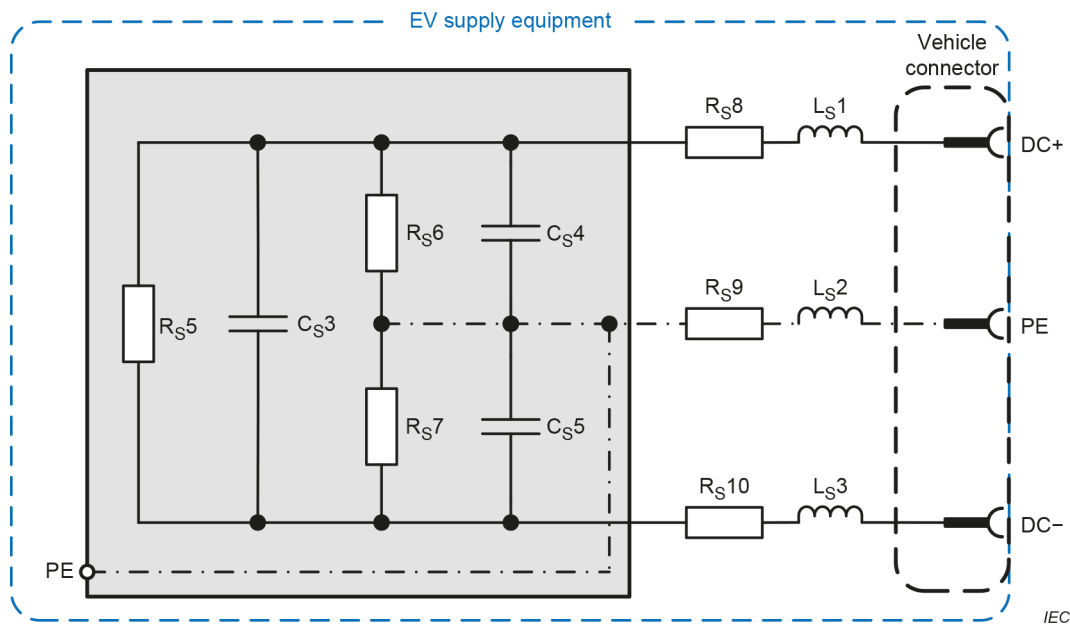

**Figure CC.3 – Equivalent disabled side B of the EV supply equipment**

**Table CC.5 – Component limits for the disabled side B of the EV supply equipment**

Component <sup>a</sup>	Minimum value <sup>a</sup>	Maximum value <sup>a</sup>
C <sub>S</sub> 4	-	500 nF
C <sub>S</sub> 5	-	500 nF
R <sub>S</sub> 6 <sup>b,c</sup>	70 kΩ	300 kΩ
R <sub>S</sub> 7 <sup>b,c</sup>	70 kΩ	300 kΩ
C <sub>S</sub> 3	-	1 μF
R <sub>S</sub> 5 <sup>c</sup>	7 kΩ	-
L <sub>S</sub> 1	-	See 101.1.8 requirements for maximum inductance at side B
L <sub>S</sub> 3 <sup>c</sup>	-	
L <sub>S</sub> 2	-	220 μH
R <sub>S</sub> 8	0 mΩ	-
R <sub>S</sub> 9	0 mΩ	-
R <sub>S</sub> 10	0 mΩ	-
	-	-
<sup>a</sup> Unspecified components or values are to be defined by the EV supply equipment manufacturer. <sup>b</sup> This value is excluding a possible insulation fault. <sup>c</sup> This component may have to withstand the complete rated maximum voltage of the EV supply equipment at side B for an extended time. NOTE When selecting the values of the components in this table, the requirements defined in 6.3.1.103, 6.3.1.113, 8.101.4, 13.101 and CC.4.5 apply.		

### CC.3 Process of energy transfer

#### CC.3.1 General

The process of energy transfer from the EV supply equipment to the EV is initiated and controlled by the messages sent over digital communication and shall follow the sequences shown in:

- CC.3.2: normal startup,
- CC.3.3: normal shutdown or pause after energy transfer,
- CC.3.4: error and emergency shutdown,
- CC.3.5: pause by EV supply equipment using ISO 15118-2:2014, and
- CC.3.6: renegotiation initiated by EV or EV supply equipment using ISO 15118-2:2014.

The messages described in DIN SPEC 70121:2014 and ISO 15118-2:2014 are abbreviated in the sequence diagrams with message codes (see Table CC.6).

NOTE 1 In Clause CC.3, the acronym EVSE is used to designate the EV supply equipment.

The EV shall not close the EV disconnection device during energy transfer stage.

If the EV disconnection device is open during the energy transfer stage, the EV shall not close the EV disconnection device without either

- performing a normal shutdown and re-initiating a new communication session by the restart sequence as specified in CC.5.2 and then continue to t1 in the normal startup sequence CC.3.2, or
- performing a renegotiation as defined in CC.3.6.

NOTE 2 Any switching event at side B (for example, the EV closing the EV disconnection device or additional battery systems during energy transfer) can cause high inrush currents at side B, overvoltages between side B live parts (DC+ and DC-) or between side B live parts (DC+/DC-) and the protective conductor, interference with the IMD, interference with basic signalling (CP or PP), or other unwanted behaviours.

**Table CC.6 – Message code mapping for sequence diagram**

Stage	Phase	Message code	DIN SPEC 70121:2014/ISO 15118-2:2014
Initialization	Preparation	Data-link	SLAC messages
		Xa	EV request messages for initialization like SDP, session setup, services, authentication, etc. as defined in IEC 61851-24.
		Xb	EVSE response messages for initialization like SDP, session setup, services, authentication, etc. as defined in IEC 61851-24.
		3a	ChargeParameterDiscoveryReq
		3b	ChargeParameterDiscoveryRes
	Cable-check	4a	CableCheckReq
		4b	CableCheckRes
	Pre-charge	5a	PreChargeReq
5b		PreChargeRes	
Energy transfer	n.a.	6a	PowerDeliveryReq
		6b	PowerDeliveryRes
		7a	CurrentDemandReq
		7b	CurrentDemandRes
		8a	PowerDeliveryReq
		8b	PowerDeliveryRes
Shutdown	EV welding detection	9a	WeldingDetectionReq
		9b	WeldingDetectionRes
	n.a.	10a	SessionStopReq
		10b	SessionStopRes

Examples of a sequence and description are shown in Figure CC.4 and Table CC.7.

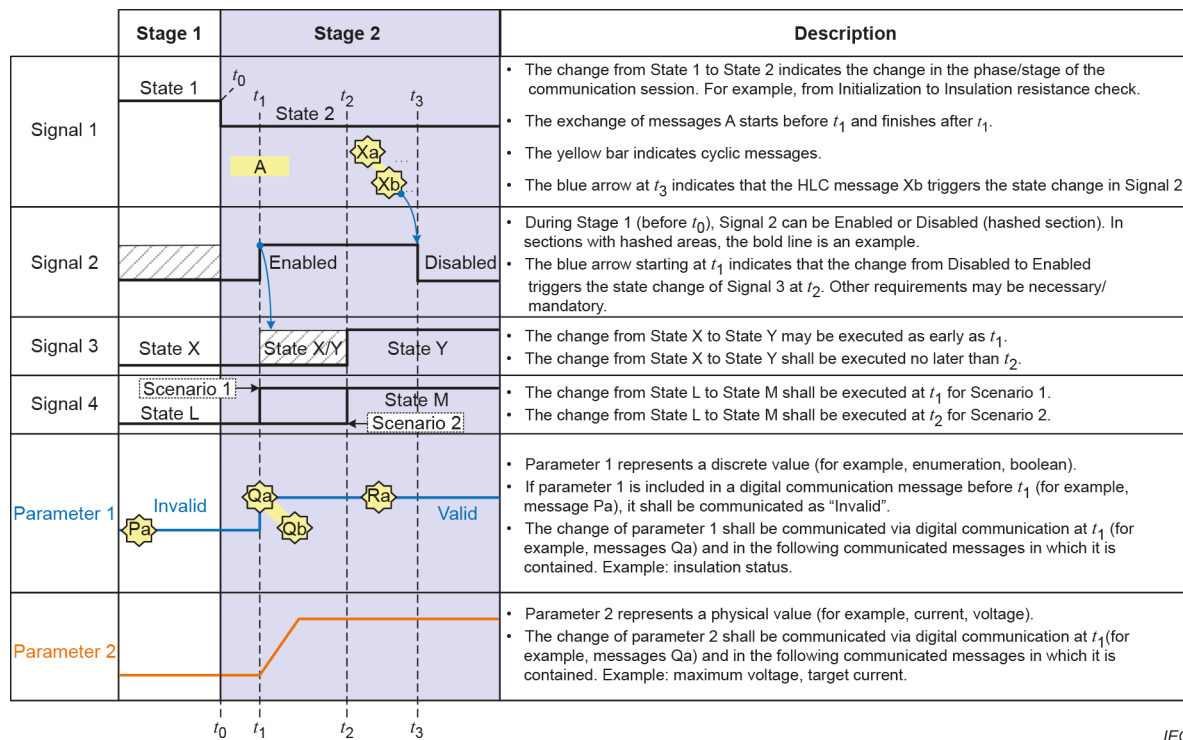

IEC

Figure CC.4 – Example of a sequence diagram

Table CC.7 – Example of a sequence description

Timestamp	Description
► ta	<ul style="list-style-type: none"> <li>Events executed before reaching ta.</li> </ul>
ta	<ul style="list-style-type: none"> <li>Events that shall be executed or completed at ta.</li> <li>The events executed at this timestamp shall be completed before reaching the next timestamp.</li> </ul>
ta ► tb	<ul style="list-style-type: none"> <li>Events that shall be executed between ta and tb.</li> <li>The events inside a timeframe (between ta and tb) shall be executed in any order and completed before reaching the next timestamp if they do not have a time constraint.</li> <li>If the event inside a timeframe has a time constraint, then tb is the moment that this event is completed.</li> </ul>
tb ►	<ul style="list-style-type: none"> <li>Events that shall be executed from tb onwards, in any order.</li> </ul>

### CC.3.2 Normal startup

The sequence diagram and description for normal startup are shown in Figure CC.5 and Table CC.8.

Compliance is checked by CC.7.5.2.

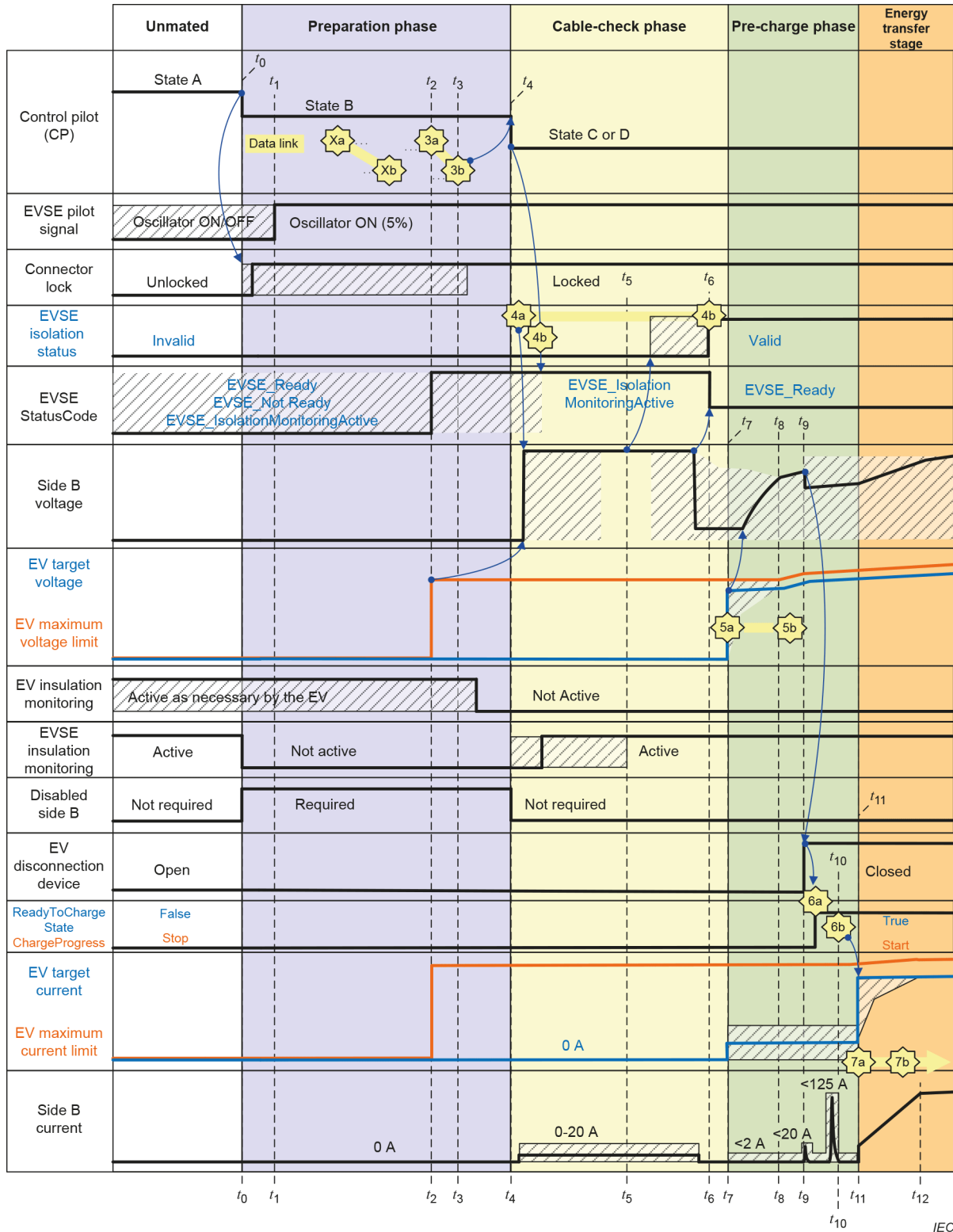

Figure CC.5 – Sequence diagram for normal startup

**Table CC.8 – Sequence description for normal startup**

Timestamp	Description
▶ t0	<ul style="list-style-type: none"> <li>The present voltage at side B between DC+ and DC– shall be <math>\leq 60</math> V DC according to 6.3.1.113.1.</li> </ul>
t0	<ul style="list-style-type: none"> <li>The vehicle connector is mated to the vehicle inlet, which changes the CP state from A to B.</li> <li>After the CP state changed to B and the PP is detected (<math>S_{\phi 3}</math> closed in case of configuration EE), the EV should lock the vehicle connector in the vehicle inlet.</li> <li>After the CP state changed to B, the EVSE shall disable the EVSE IMD, disable side B and open the EVSE disconnection device, if any.</li> <li>After the CP state changed to B, the EV may try to set up a data link as defined in IEC 61851-24.</li> </ul>
t0 ▶ t3	<ul style="list-style-type: none"> <li>The EVSE shall not trigger an error shutdown due to the present voltage at side B (including negative voltages).</li> </ul> <p>When the vehicle connector is mated to the vehicle inlet, these voltages can be supplied by an EV according to the requirements for unmated conditions in ISO 17409:2020, 6.5.2. EV supply equipment based on IEC 61851-23:2014 shall trigger a shutdown if the present voltage at side B is <math>&gt; 60</math> V DC in the first ChargeParameterDiscoveryReq &lt;3a&gt; message.</p>
t0 ▶ t4	<ul style="list-style-type: none"> <li>If the EV tried and failed to lock the vehicle connector, the EV shall notify the EVSE with parameter "EVErrorCode" = 'FAILED_ChargerConnectorLockFault' in the next communicated message that contains this parameter, according to IEC 61851-24.</li> <li>The disabled side B of the EVSE shall have equivalent electrical properties/behaviour (for example, impedance, discharge rate, etc.) as the circuit described in CC.2.4.</li> </ul>
t0 ▶ t10	<ul style="list-style-type: none"> <li>The EVSE shall not perform the overvoltage protection according to 6.3.1.106.</li> </ul>
t1	<ul style="list-style-type: none"> <li>The EVSE shall turn on its CP oscillator if the EVSE is ready for energy transfer and if the CP oscillator is not already on.</li> <li>The EVSE shall maintain a CP duty cycle of 5 % from the start of the data link setup until end of communication session, unless a certain condition requires a different CP duty cycle.</li> </ul>
t1 ▶ t2	<ul style="list-style-type: none"> <li>The EV shall establish the data link as defined in the IEC 61851-24 after it has verified that the EVSE has turned on its CP oscillator, if the data link is not already established.</li> </ul> <p>NOTE 1 The data link could have been previously established due to a pause or renegotiation of the communication session.</p> <ul style="list-style-type: none"> <li>Digital communication starts by the negotiation of an appropriate application layer protocol between the EV &lt;Xa&gt; and EVSE &lt;Xb&gt;. See Table CC.6.</li> <li>The EV and EVSE exchange message pairs concerning session setup, services, authentication, payment options and value-added services (if supported by the negotiated application layer protocol). According to IEC 61851-24, some message pairs are not necessary after a pause or renegotiation, for example, authentication or payment options.</li> <li>If the EVSE wants to terminate the communication session during the initialization stage (for example, user pressed the stop button), the EVSE shall <ul style="list-style-type: none"> <li>send parameter "ResponseCode" = 'FAILED' in the next communicated message,</li> <li>keep its CP oscillator on (unless a certain condition requires a different CP duty cycle), and</li> <li>proceed to t206 in the error shutdown sequence.</li> </ul> </li> </ul> <p>NOTE 2 If next communicated message is a ChargeParameterDiscoveryRes &lt;3b&gt; message, see t2 ▶ t4.</p> <ul style="list-style-type: none"> <li>If, after the EV has received a response message, the EV wants to terminate the communication session, the EV shall proceed to t107 in the normal shutdown sequence.</li> <li>If the EV receives a response message with parameter "ResponseCode" = 'FAILED', the EV shall proceed to t206 in the error shutdown sequence.</li> </ul>
t2	<ul style="list-style-type: none"> <li>The EV shall send parameters "EVMaximumVoltageLimit" and "EVMaximumCurrentLimit" (amongst other parameters) with the first ChargeParameterDiscoveryReq &lt;3a&gt; message.</li> </ul>

Timestamp	Description
t2 ► t3	<ul style="list-style-type: none"> <li>• The EVSE shall perform a compatibility check. See CC.5.6.</li> <li>• The EVSE shall check if the absolute value of the present voltage at side B between DC+ and DC– is &lt; 60 V DC and shall send message ChargeParameterDiscovery &lt;3b&gt; with parameter "EVSEProcessing" = 'Ongoing' if the absolute value of the present voltage at side B is ≥ 60 V DC.</li> <li>• The EVSE shall send parameters "EVSEMaximumVoltageLimit", "EVSEMinimumVoltageLimit", "EVSEMaximumCurrentLimit" and "EVSEMinimumCurrentLimit" (amongst other parameters) in message ChargeParameterDiscoveryRes &lt;3b&gt; considering the compatibility check. See CC.5.6 on how to calculate these values.</li> <li>• The EVSE shall send parameter "EVSEStatusCode" = 'EVSE_IsolationMonitoringActive' in the "ChargeParameterDiscoveryRes &lt;3b&gt;" messages, unless the EVSE wants to pause the communication session or perform a shutdown. The EV is recommended to continue the communication session if the EVSE sends ChargeParameterDiscoveryRes &lt;3b&gt; messages with parameter "EVSE_StatusCode" = 'EVSE_Ready' or 'EVSE_NotReady'.</li> </ul> <p>NOTE 3 EVSEs based on IEC 61851-23:2014 can send parameter "EVSE_StatusCode" = "EVSE_Ready", "EVSE_NotReady", or "EVSE_IsolationMonitoringActive" in ChargeParameterDiscoveryRes &lt;3b&gt; messages.</p> <ul style="list-style-type: none"> <li>• If the EVSE replies with parameters "ResponseCode" = 'OK' and "EVSEProcessing" = 'Ongoing' in message ChargeParameterDiscoveryRes &lt;3b&gt;, the EV and EVSE may update the parameters sent in the next ChargeParameterDiscoveryReq/Res messages.</li> </ul> <p>NOTE 4 The EVSE can use "EVSEProcessing" = 'Ongoing' for other reasons. Example: load management, etc.</p> <ul style="list-style-type: none"> <li>• If using DIN SPEC 70121:2014: if the EVSE wants to pause the communication session during the initialization stage, the EVSE shall send parameters "EVSEStatusCode" = 'EVSE_UtilityInterruptEvent' and "EVSEProcessing" = 'Ongoing' in the next ChargeParameterDiscoveryRes &lt;3b&gt; message and then continue to t3 with parameter "EVSEStatusCode" = 'EVSE_Shutdown'.</li> </ul> <p>NOTE 5 The EVSE sends "EVSEStatusCode" = 'EVSE_UtilityInterruptEvent' and "EVSEProcessing" = 'Ongoing' to indicate to the EV the reason for performing a normal shutdown before energy transfer.</p> <ul style="list-style-type: none"> <li>• If the EV sends parameter "EVErrorcode" = 'FAILED_ChargerConnectorLockFault' in a ChargeParameterDiscoveryReq &lt;3a&gt; message, the EVSE should respond with cyclic ChargeParameterDiscoveryRes &lt;3b&gt; messages with parameters "EVSEProcessing" = 'Ongoing' and "ResponseCode" = 'OK' to give the EV additional time to solve the fault in the locking mechanism. See CC.5.6 for additional conditions for the EVSE to send "EVSEProcessing" = 'Ongoing' during cyclic ChargeParameterDiscoveryReq/Res messages.</li> </ul> <p>The EVSE should inform the user how to improve the locking process. For example, by indicating how to properly mate the vehicle connector in the vehicle inlet.</p> <ul style="list-style-type: none"> <li>• According to DIN SPEC 70121:2014, the EV shall resend the identical parameters in each ChargeParameterDiscoveryReq message; however, it is recommended for the EVSE not to perform a shutdown if the EV changes the parameters.</li> <li>• ISO 15118-2:2014 does not specify the possibility to update the parameters in subsequent ChargeParameterDiscoveryReq/Res messages; however, it is recommended for the EVSE not to perform a shutdown if the EV changes the parameters.</li> <li>• To improve interoperability, the EVSE shall tolerate the EV changing CP state to C/D during cyclic ChargeParameterDiscoveryReq/Res messages. If the EV changes back to CP state B, the EVSE shall trigger an EVSE initiated emergency shutdown. See CC.3.4.3.</li> </ul> <p>Requirement [V2G2-912] in ISO 15118-2:2014 and a similar requirement in outdated versions of SAE J1772 do not specify that the EV shall receive a ChargeParameterDiscoveryRe &lt;3b&gt; with parameter "EVSEProcessing" = "Finished" before changing the CP state from state B to state C/D, leading to this unwanted behaviour.</p>
t2 ► t4	<ul style="list-style-type: none"> <li>• If the EVSE wants to terminate the communication session during the initialization stage (for example, user pressed the stop button), the EVSE shall send parameter "EVSEStatusCode" = 'EVSE_Shutdown' in the next communicated message and proceed to t107 in the normal shutdown sequence. If using ISO 15118-2:2014, the EVSE shall also send parameter "EVSENotification" = 'StopCharging'.</li> <li>• If, after the EV has received a response message, the EV wants to terminate the communication session, or if the EV receives a response message with parameter "EVSEStatusCode" = 'EVSE_Shutdown' (and, if using ISO 15118-2:2014, parameter "EVSENotification" = 'StopCharging'), the EV shall proceed to t107 in the normal shutdown sequence.</li> </ul>

Timestamp	Description
t3	<ul style="list-style-type: none"> <li>• If the absolute value of the present voltage at side B is &lt; 60 V DC, the EVSE shall send the EV the result of the compatibility check in message ChargeParameterDiscoveryRes &lt;3b&gt; using parameters "EVSEStatusCode" = 'EVSE_IsolationMonitoringActive', "EVSEProcessing" = 'Finished', and:               <ul style="list-style-type: none"> <li>– "ResponseCode" = 'OK' if the compatibility check was successfully completed, or</li> <li>– "ResponseCode" = 'FAILED_WrongChargeParameter' if the compatibility check was completed and failed, triggering an EVSE initiated error shutdown.</li> </ul> </li> </ul> <p>NOTE 6 A ChargeParameterDiscoveryRes &lt;3b&gt; message with "ResponseCode" = 'FAILED_WrongChargeParameter' and parameter "EVSEProcessing" = 'Ongoing' will trigger an EVSE initiated error shutdown. See error handling specifications for the digital communication standards in IEC 61851-24.</p> <p>If the absolute value of the present voltage at side B is not &lt; 60 V DC at the end of the compatibility check (based on the timing requirements of IEC 61851-24), the EVSE cannot send a ChargeParameterDiscoveryRes &lt;3b&gt; message with parameter "EVSEProcessing" = 'Finished'. In this case, the EV shall trigger an error shutdown.</p> <p>NOTE 7 EVSEs based on IEC 61851-23:2014 can send parameter "EVSE_StatusCode" = "EVSE_Ready", "EVSE_NotReady", or "EVSE_IsolationMonitoringActive" in ChargeParameterDiscoveryRes &lt;3b&gt; messages. The EV is recommended to continue the communication session if the EVSE sends ChargeParameterDiscoveryRes &lt;3b&gt; messages with parameter "EVSE_StatusCode" = 'EVSE_Ready' or 'EVSE_NotReady'.</p> <ul style="list-style-type: none"> <li>• The negotiated maximum values sent by the EVSE in the last ChargeParameterDiscoveryRes &lt;3b&gt; shall be more than or equal to the applicable values in the CurrentDemandRes &lt;7b&gt; messages during the energy transfer stage. See CC.5.6.</li> </ul>
t3 ► t4	<ul style="list-style-type: none"> <li>• If the EV and EVSE are not compatible, the EV shall perform an EV initiated error shutdown. See CC.3.4.2.</li> <li>• The EV shall lock the vehicle connector in the vehicle inlet before changing the CP to state C or D, if not already locked.</li> <li>• If the EV failed to lock the vehicle connector, the EV shall trigger an EV initiated error shutdown with parameter "EVErrorCode" = 'FAILED_ChargerConnectorLockFault' in the next communicated message.</li> <li>• The EV shall disable the EV IMD, if any.</li> </ul>
t3 ►	<ul style="list-style-type: none"> <li>• The EVSE shall trigger an error shutdown if the present voltage at side B between DC+ and DC– is &lt; -60 V DC for 400 consecutive ms or more.</li> </ul>
t4	<ul style="list-style-type: none"> <li>• After the EV has disabled the EV IMD and after checking that the vehicle connector is locked, the EV shall change the CP state from B to C/D by closing <math>S_{V2}</math>.</li> </ul> <p>The common mode and differential mode influences from the EV (for example, welding detection, IMD, etc) on side B should be removed before the EV changes the CP state from B to C/D by closing <math>S_{V2}</math> because this can interfere with the EVSE IMD.</p> <ul style="list-style-type: none"> <li>• After the CP state changed to C/D, the EVSE shall enable side B. The limitations of the disabled side B of the EVSE are not required.</li> </ul>
t4 ► t5	<ul style="list-style-type: none"> <li>• After checking that the vehicle connector is locked, the EV shall request cable-check phase before pre-charge phase with CableCheckReq &lt;4a&gt;. See CC.4.1.4.</li> <li>• The EVSE shall check if the CP state changed to state C or D before sending the first CableCheckRes &lt;4b&gt; message and before the present voltage at side B between DC+ and DC– is &gt; 60 V DC.</li> </ul>

Timestamp	Description
t4 ► t6	<ul style="list-style-type: none"> <li>• The EVSE shall check the functionality of the IMD. See CC.4.1.2 and CC.4.1.3.</li> <li>• The EVSE shall check the insulation of side B and shall continuously report the insulation state with parameter "EVSEIsolationStatus" according to CC.4.1.4, "EVSEProcessing" = 'Ongoing', and "EVSEStatusCode" = 'EVSE_IsolationMonitoringActive' in message CableCheckRes&lt;4b&gt;.</li> <li>• The EVSE may perform other functions (for example, welding detection) while sending parameters "EVSEIsolationStatus" according to CC.4.1.4 and "EVSEProcessing" = 'Ongoing' in message CableCheckRes&lt;4b&gt;.</li> </ul>
t4 ► t10	<ul style="list-style-type: none"> <li>• If using DIN SPEC 70121:2014: If the EVSE wants to pause the communication session during the cable-check phase or pre-charge phase, the EVSE shall disable side B (see CC.2.4) and, if the next communicated message is             <ul style="list-style-type: none"> <li>– a CableCheckRes &lt;4b&gt; or PreChargeRes &lt;5b&gt; message, the EVSE shall first send a response message with parameter "EVSEStatusCode" = 'EVSE_UtilityInterruptEvent' and a response message with parameter "EVSEStatusCode" = 'EVSE_Shutdown' in the next communicated message to proceed to t107 in the normal shutdown sequence after sending the response message (see CC.3.3), or</li> <li>– a PowerDeliveryRes &lt;6b&gt; message, the EVSE shall send parameter "EVSEStatusCode" = 'EVSE_Shutdown', for the EV to initiate a normal shutdown (see CC.3.3).</li> </ul> </li> </ul> <p>NOTE 8 If the next communicated message is a CurrentDemandRes &lt;7b&gt; message, a communication session termination will result in a normal shutdown. See CC.3.3.</p> <p>NOTE 9 Some EVs might interpret messages with parameter "EVSEStatusCode" = 'EVSE_UtilityInterruptEvent' as "EVSEStatusCode" = 'EVSE_Shutdown'.</p> <ul style="list-style-type: none"> <li>• If the EVSE wants to terminate the communication session during the cable-check phase or pre-charge phase, the EVSE shall disable side B (see CC.2.4) and send parameter "EVSEStatusCode" = 'EVSE_Shutdown' (and, if using ISO 15118-2:2014, parameter "EVSENotification" = 'StopCharging'), in the next communicated message. If the next communicated message is             <ul style="list-style-type: none"> <li>– a CableCheckRes &lt;4b&gt; or PreChargeRes &lt;5b&gt; message, the EVSE shall proceed to t107 in the normal shutdown sequence after sending the response message (see CC.3.3), or</li> <li>– a PowerDeliveryRes &lt;6b&gt; message, the EV shall initiate a normal shutdown (see CC.3.3).</li> </ul> </li> </ul> <p>NOTE 10 If the next communicated message is a CurrentDemandRes &lt;7b&gt; message, a communication session termination will result in a normal shutdown. See CC.3.3.</p> <ul style="list-style-type: none"> <li>• If the EV wants to terminate the communication session during the cable-check phase or pre-charge phase, after receiving a response message, the EV shall             <ul style="list-style-type: none"> <li>– if it has not yet closed the EV disconnection device, proceed to t107 in the normal shutdown sequence (see CC.3.3), or</li> <li>– if it has already closed the EV disconnection device, initiate a normal shutdown (see CC.3.3).</li> </ul> </li> <li>• If the EV receives a response message with parameter "EVSEStatusCode"='EVSE_Shutdown' (and, if using ISO 15118-2:2014, parameter "EVSENotification" = 'StopCharging'), during the cable-check phase or pre-charge phase, the EV shall             <ul style="list-style-type: none"> <li>– if it has not yet closed the EV disconnection device, proceed to t107 in the normal shutdown sequence (see CC.3.3), or</li> <li>– if it has already closed the EV disconnection device, initiate a normal shutdown (see CC.3.3).</li> </ul> </li> </ul>
t5	<ul style="list-style-type: none"> <li>• The EVSE determines that the insulation resistance of side B is <math>\geq 100 \text{ k}\Omega</math>. See CC.4.1.1.</li> </ul>
t6	<ul style="list-style-type: none"> <li>• After completing the cable-check phase, the EVSE shall send message CableCheckRes &lt;4b&gt; with parameters "EVSEIsolationStatus" according to CC.4.1.4, "EVSEProcessing" = 'Finished', and             <ul style="list-style-type: none"> <li>– "EVSEStatusCode" = "Ready", if the insulation status is 'Valid' and there are no errors, or</li> <li>– "ResponseCode" = 'FAILED', if the EVSE detects an error, to trigger an EVSE initiated error shutdown.</li> </ul> </li> <li>• If the EVSE detects an error, the EVSE shall trigger an EVSE initiated error shutdown by sending parameters "EVSEIsolationStatus" according to CC.4.1.4 and "ResponseCode" = 'FAILED' in message CableCheckRes &lt;4b&gt;.</li> </ul>
t6 ► t7	<ul style="list-style-type: none"> <li>• The EVSE may keep the present voltage at side B.</li> </ul>

Timestamp	Description
t7	<ul style="list-style-type: none"> <li>The EV shall send message PreChargeReq &lt;5a&gt;, with parameter "EVTargetVoltage" depending on the present voltage of the battery system, to start the pre-charge phase. See CC.5.1.</li> </ul>
t7 ► t9	<ul style="list-style-type: none"> <li>The EV and EVSE shall perform the pre-charge phase according to CC.5.1.</li> <li>The EVSE shall control the present voltage at side B according to the target voltage of the EV in the PreChargeReq &lt;5a&gt; messages, and send the corresponding PreChargeRes &lt;5b&gt; messages.</li> </ul>
t8	<ul style="list-style-type: none"> <li>The present voltage at side B reaches the target voltage of the EV between the tolerances given in 101.1.2.</li> </ul>
t8 ► t9	<ul style="list-style-type: none"> <li>The EV may adapt the target voltage of the EV with cyclic PreChargeReq/Res messages to compensate for voltage deviation.</li> </ul>
t9	<ul style="list-style-type: none"> <li>The EV shall close the EV disconnection device only after verifying that the absolute difference between the present voltage at side B and the present voltage at the battery system is &lt; 20 V DC. See CC.5.1.</li> </ul> <p>The EV should be protected against reversed polarity of side B.</p>
t9 ► t10	<ul style="list-style-type: none"> <li>The EV shall request the EVSE to disable its pre-charge current limitation by sending message PowerDeliveryReq &lt;6a&gt; according to IEC 61851-24, only after closing the EV disconnection device.</li> </ul> <p>NOTE 11 When using DIN SPEC 70121:2014, use parameter "ReadyToChargeState" = 'TRUE'. When using ISO 15118-2:2014, use parameter "ChargeProgress" = 'Start'.</p>
t10	<ul style="list-style-type: none"> <li>After disabling the pre-charge current limitation (for example, pre-charge circuit, if any), and enabling side B, the EVSE shall send message PowerDeliveryRes &lt;6b&gt; with parameter "EVSEStatusCode" = 'EVSE_Ready' to indicate that it is ready for energy transfer and overvoltage protection (see 6.3.1.106).</li> <li>The EVSE shall start the overvoltage protection according to 6.3.1.106.</li> </ul>
t11	<ul style="list-style-type: none"> <li>The EV shall set parameter "EVTargetCurrent" in the first CurrentDemandReq &lt;7a&gt; message to start the energy transfer stage.</li> <li>The EV shall send CurrentDemandReq &lt;7a&gt; messages with parameters "EVMaximumVoltageLimit" and "EVMaximumCurrentLimit" less than or equal to the respective negotiated limits sent in the last ChargeParameterDiscoveryReq &lt;3a&gt; message. See CC.5.6.</li> </ul>
t11 ► t12	<ul style="list-style-type: none"> <li>The EVSE shall adapt the side B to the target values by the EV in message CurrentDemandReq &lt;7a&gt;.</li> <li>The EVSE shall respond to the EV with the following information in message CurrentDemandRes&lt;7b&gt;: <ul style="list-style-type: none"> <li>present current and voltage at side B;</li> <li>applicable minimum and maximum values for current, voltage and power of the EV supply equipment at side B;</li> <li>its present status.</li> </ul> </li> </ul> <p>The EV may change the target current and voltage of the EV even if the present current and voltage at side B has not reached the previous target values.</p>
t11 ►	<ul style="list-style-type: none"> <li>The EVSE shall continuously monitor the insulation of side B and update parameter "EVSEIsolationStatus" in the next communicated messages that contain this parameter. See CC.4.1.6.</li> </ul>
t12	<ul style="list-style-type: none"> <li>The present current at side B reaches the target current of the EV in the time delay (Td) or less defined in 101.1.3.</li> </ul>
t12 ►	<ul style="list-style-type: none"> <li>The EV adapts the target current and voltage of the EV according to its energy transfer strategy by setting parameters "EVTargetCurrent" and "EVTargetVoltage" in cyclic CurrentDemandReq &lt;7a&gt; messages.</li> </ul> <p>NOTE See CC.5.5 for the handling of operating ranges and CC.5.7 for the target values considerations in CCM and CVM.</p>

### CC.3.3 Normal shutdown or pause after energy transfer

The sequence diagram and description for normal shutdown or pause after energy transfer are shown in Figure CC.6 and Table CC.9.

After the completion of normal shutdown or pause during energy transfer, the EV shall not induce voltages at side B more than the values specified in 6.3.1.113.2.

Compliance is checked by CC.7.6.18.

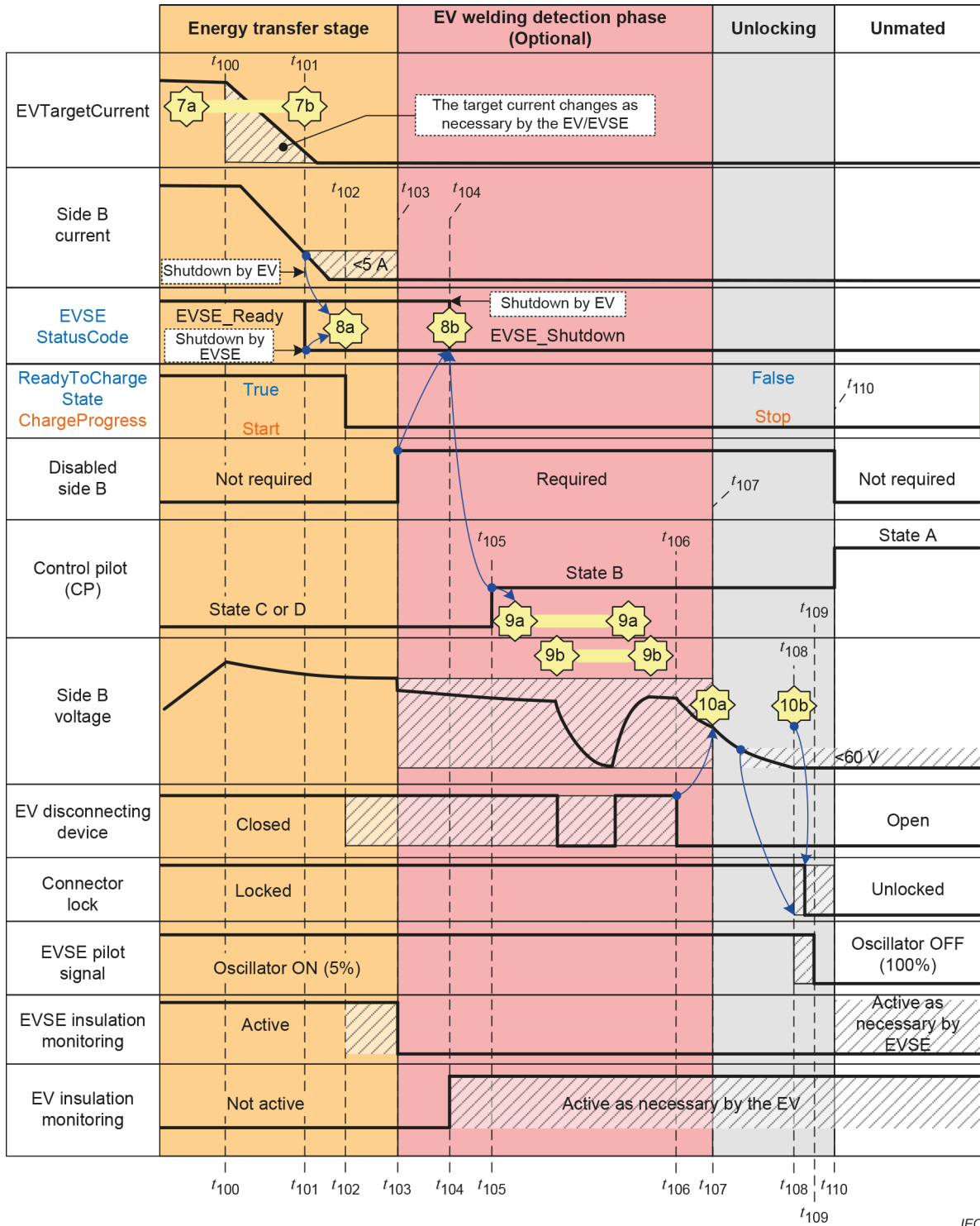

**Figure CC.6 – Sequence diagram for normal shutdown or pause after energy transfer by EV or EV supply equipment**

**Table CC.9 – Sequence description for normal shutdown or pause after energy transfer by EV or EV supply equipment**

Timestamp	Description
► t100	<ul style="list-style-type: none"> <li>Cyclic CurrentDemandReq/Res messages between the EV (CurrentDemandReq &lt;7a&gt;) and EVSE (CurrentDemandRes &lt;7b&gt;).</li> </ul>
t100	<ul style="list-style-type: none"> <li>If the EV wants to stop or pause a communication session for a non-critical reason, the EV shall request a reduction of the present current at side B to 0 A DC in the next CurrentDemandReq &lt;7a&gt; messages.</li> </ul>
t100 ► t101	<ul style="list-style-type: none"> <li>If the EVSE wants to stop or pause a communication session for a non-critical reason (for example, user pressed the stop button), the EVSE shall <ul style="list-style-type: none"> <li>ramp down the present current at side B to &lt; 5 A DC, and</li> <li>adjust parameter "EVSEMaximumCurrentLimit" in the next CurrentDemandRes &lt;7b&gt; messages according to the present current at side B.</li> </ul> </li> </ul> <p>See 101.1.3, CC.5.5.4 and CC.5.5.6.</p> <p>NOTE 1 EVs based on IEC 61851-23:2014 might directly go to t102 without reducing the target current of the EV. This will be interpreted as an EV initiated error shutdown by the EVSE (DIN SPEC 70121:2014, 9.7.4.1.2). See Table CC.10.</p> <p>NOTE 2 The EVSE can limit the present current at side B ramp down to –20 A/s to avoid sudden load variations at side A (for example, supply network connection).</p>
t101	<ul style="list-style-type: none"> <li>The present current at side B is &lt; 5 A DC.</li> </ul>
t101 ► t102	<ul style="list-style-type: none"> <li>If the EVSE wants to stop or pause the communication session and the present current at side B is &lt; 5 A DC, the EVSE shall <ul style="list-style-type: none"> <li>first, set parameter "EVSEStatusCode" = 'EVSE_UTILITYInterruptEvent' in the next CurrentDemandRes &lt;7b&gt; message to pause the communication session, and</li> <li>second, if the EVSE did not receive a "PowerDeliveryRes" &lt;8a&gt; message (t102), set "EVSEStatusCode" = 'EVSE_Shutdown' (and, if using ISO 15118-2:2014, parameter "EVSENotification" = 'StopCharging'), in the next CurrentDemandRes &lt;7b&gt; message to stop the communication session.</li> </ul> </li> </ul>
t102	<ul style="list-style-type: none"> <li>If using DIN SPEC 70121:2014: If the EV wants to stop the communication session or if the EVSE wants to stop or pause the communication session (that is, the EV received a CurrentDemandRes &lt;7b&gt; message with parameter "EVSEStatusCode" = 'EVSE_Shutdown' or 'EVSE_UTILITYInterruptEvent'), the EV shall request the EVSE to disable side B by sending parameter "ReadyToChargeState" = 'FALSE' in the PowerDeliveryReq &lt;8a&gt; message according to IEC 61851-24, after the present current at side B is &lt; 5 A DC.</li> <li>If using ISO 15118-2:2014: If the EV wants to stop the communication session or if the EVSE wants to stop or pause the communication session (that is, the EV received a CurrentDemandRes &lt;7b&gt; message with parameter "EVSEStatusCode" = 'EVSE_Shutdown' and "EVSENotification" = 'StopCharging' or 'EVSE_UTILITYInterruptEvent'), the EV shall request the EVSE to disable side B by sending parameter "ChargeProgress" = 'Stop' in the PowerDeliveryReq &lt;8a&gt; message according to IEC 61851-24, after the present current at side B is &lt; 5 A DC.</li> </ul> <p>NOTE 3 From t102 onwards, the sequences for EV initiated normal shutdown and EVSE initiated normal shutdown are identical.</p>
t102 ► t103	<ul style="list-style-type: none"> <li>After receiving the PowerDeliveryReq &lt;8a&gt; message, the EVSE shall reduce the present current at side B to &lt; 5 A DC in 1 s or less, if not already done.</li> </ul> <p>NOTE This is needed for EVs based on IEC 61851-23:2014.</p> <ul style="list-style-type: none"> <li>After receiving the PowerDeliveryReq &lt;8a&gt; message, the EVSE shall stop the overvoltage protection according to 6.3.1.106.</li> </ul>
t102 ► t105	<ul style="list-style-type: none"> <li>The EV may open the EV disconnection device after the present current at side B is &lt; 5 A DC and after the message PowerDeliveryReq &lt;8a&gt; has been sent. In this case, the EV shall not re-close the EV disconnection device.</li> </ul>
t103	<ul style="list-style-type: none"> <li>The EVSE shall disable side B and open the EVSE disconnection device, if any.</li> </ul> <p>NOTE 4 If the EVSE disables side B while the present current at side B is &gt; 0 A DC, the present voltage at side B drops to the battery system voltage because the EV disconnection device is still closed.</p> <ul style="list-style-type: none"> <li>The EVSE shall disable the EVSE IMD.</li> </ul>

Timestamp	Description
t103 ► t110	<ul style="list-style-type: none"> <li>The disabled side B of the EVSE shall have equivalent electrical properties/behaviour (for example, impedance, discharge rate, etc.) as the circuit described in CC.2.4.</li> </ul>
t104	<ul style="list-style-type: none"> <li>The EVSE shall communicate that the present current at side B is &lt; 5 A DC and has disabled side B by sending parameter "EVSEStatusCode" = 'EVSE_Shutdown' or 'EVSE_UtilityInterruptEvent' in message PowerDeliveryRes &lt;8b&gt;.</li> <li>The EV may enable the EV IMD, if any.</li> </ul>
t104 ► t107	<ul style="list-style-type: none"> <li>If the EVSE has not received a SessionStopReq &lt;10a&gt; message 20 s after sending the PowerDeliveryRes &lt;8b&gt; message, the EVSE shall trigger an error shutdown.</li> </ul>
t105	<ul style="list-style-type: none"> <li>The EV shall change the CP state to B after receiving message PowerDeliveryRes &lt;8b&gt;.</li> </ul> <p>NOTE 5 If the EV decides not to perform welding detection, it proceeds to t106.</p>
t105 ► t106	<ul style="list-style-type: none"> <li>The EV may actuate the EV disconnection device multiple times during welding detection.</li> <li>The EV may send multiple WeldingDetectionReq &lt;9a&gt; messages in order to read the present voltage at side B measured by the EVSE in the WeldingDetectionRes &lt;9b&gt; messages.</li> <li>The EVSE shall check if the CP state changed to state B before sending the first WeldingDetectionRes &lt;9b&gt; message.</li> </ul>
t106	<ul style="list-style-type: none"> <li>The EV completes welding detection, if performed.</li> <li>The EV shall open the EV disconnection device.</li> </ul> <p>NOTE 6 Opening of the EV disconnection device starts the reduction of the present voltage at side B by passive discharge because the EVSE has not yet received message SessionStopReq &lt;10a&gt;.</p>
t107	<ul style="list-style-type: none"> <li>The EV shall send the SessionStopReq &lt;10a&gt; message after it has opened the EV disconnection device.</li> <li>If using DIN SPEC 70121:2014, the EV sending the SessionStopReq &lt;10a&gt; message will terminate the communication session.</li> <li>If using ISO 15118-2:2014, the EV may, in message SessionStopReq &lt;10a&gt;, use parameter             <ul style="list-style-type: none"> <li>"ChargingSession" = 'Pause' to initiate a communication session pause, or</li> <li>"ChargingSession" = 'Pause' if the EVSE sent parameter "EVSEStatusCode" = 'EVSE_UtilityInterruptEvent' in one of the CurrentDemandRes &lt;7b&gt; messages or in the PowerDeliveryRes &lt;8b&gt; message, or</li> <li>"ChargingSession" = 'Terminate' to terminate digital communication. See IEC 61851-24.</li> </ul> </li> </ul>
t107 ► t108	<ul style="list-style-type: none"> <li>The EVSE shall, in 1 s or less, reduce and maintain the present voltage at side B between DC+ and DC- ≤ 60 V DC.</li> </ul> <p>NOTE 7 The EVSE can actively discharge the side B because the EV has opened the EV disconnection device.</p>
t108	<ul style="list-style-type: none"> <li>The EVSE shall send the SessionStopRes &lt;10b&gt; message.</li> <li>If using ISO 15118-2:2014, the EVSE shall turn off its CP oscillator.</li> </ul>
t108 ► t110	<ul style="list-style-type: none"> <li>The EV should unlock the vehicle connector after the SessionStopRes &lt;10b&gt; message is received. The requirements for unlocking are defined in ISO 17409.</li> <li>If supported by the EVSE, the EV may wake up the EVSE and re-initiate a communication session (see CC.5.2). The communication session shall restart after the restart process at t1 in the normal startup sequence (see CC.3.2).</li> <li>If digital communication according to ISO 15118 is used, the EV may request a pause (see CC.3.5). The communication session shall restart after the pause process at t1 in the normal startup sequence (see CC.3.2).</li> <li>Any subsequent re-initiation of a new communication session shall use the restart sequence as specified in CC.5.2 and continue to t1 in the normal startup sequence CC.3.2.</li> </ul>
t109	<ul style="list-style-type: none"> <li>If using DIN SPEC 70121:2014, the EVSE shall turn off its CP oscillator 1,5 s after sending the SessionStopRes &lt;10b&gt; message.</li> </ul>
t110	<ul style="list-style-type: none"> <li>Un-mating the vehicle connector changes the CP state from B to A.</li> <li>The limitations of the disabled side B are not required.</li> </ul>

### CC.3.4 Error and emergency handling

#### CC.3.4.1 General

The EV supply equipment and EV shall have means to initiate error or emergency shutdowns.

NOTE An error shutdown is to prevent damage to the equipment. An emergency shutdown is to protect the user from a hazardous situation.

Table CC.10 gives an overview of the error and emergency shutdown cases defined in this document.

**Table CC.10 – Overview of error and emergency shutdown cases**

Type of shutdown	Case
Error shutdown	Cable check errors (6.3.1.105 and CC.4.1.4)
	Insulation monitoring during energy transfer (CC.4.1.6)
	Protection against overvoltage at side B between DC+ and DC– (see 6.3.1.106.3)
	Overtemperature handling (101.2.3.2)
	Check of the plausibility of the values provided by the thermal sensing (101.2.3.3)
	Short-circuit before energy transfer (6.3.1.109)
	Maximum voltage between side B live parts (DC+/DC–) and the protective conductor in conditions with a single fault to protective conductor (6.3.1.112.2)
Emergency shutdown	Loss of electrical continuity of the control pilot conductor (CC.4.3)
	Loss of electrical continuity of the proximity detection conductor (CC.4.4)
	Overcurrent protection (CC.6.4)
	Protection against overvoltage at side B between DC+ and DC– (6.3.1.106.2)
	Control circuit supply integrity (6.3.1.108)
	Loss of electrical continuity the protective conductor (6.3.1.2 and CC.4.7)
	Short-circuit protection (13.101)
	If error shutdown does not work properly (CC.3.4.2)

Other reasons for error or emergency shutdowns are specified in the respective digital communication protocol as defined in IEC 61851-24.

#### CC.3.4.2 EV supply equipment and EV initiated error shutdown

Sequence diagrams and descriptions for EV supply equipment and EV initiated error shutdown based on ISO 15118-2:2014 and DIN SPEC 70121:2014 are shown in Figure CC.7 and Table CC.11.

If the digital communication is based on DIN SPEC 70121:2014 and an error occurs during energy transfer, the EV can initiate an error shutdown as defined in the sequence diagram and description in Figure CC.8 and Table CC.12. In this case, the EV can enter the welding detection phase.

After the completion of an error shutdown, the EV shall not induce voltages at side B more than the values specified in 6.3.1.113.3.

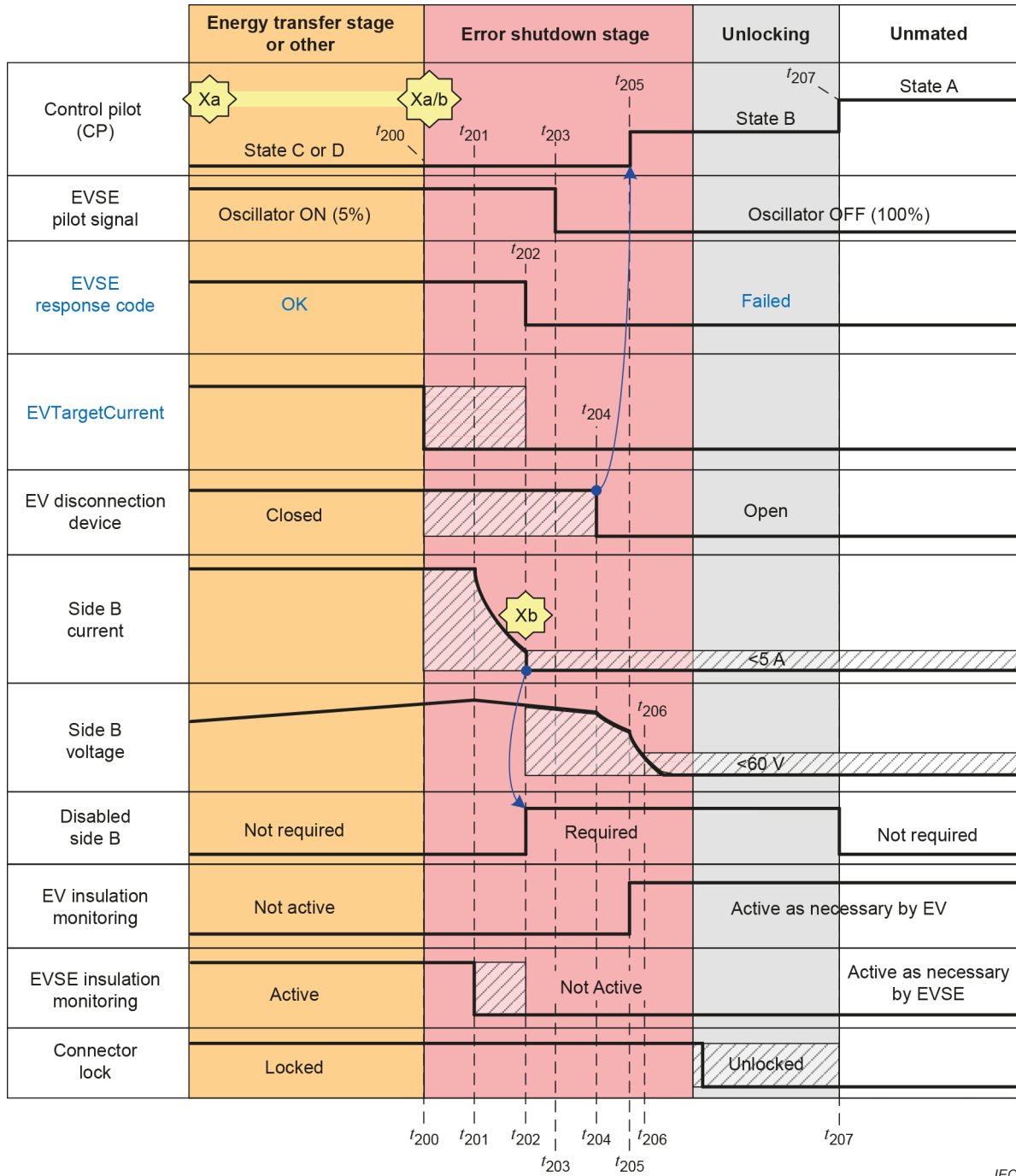
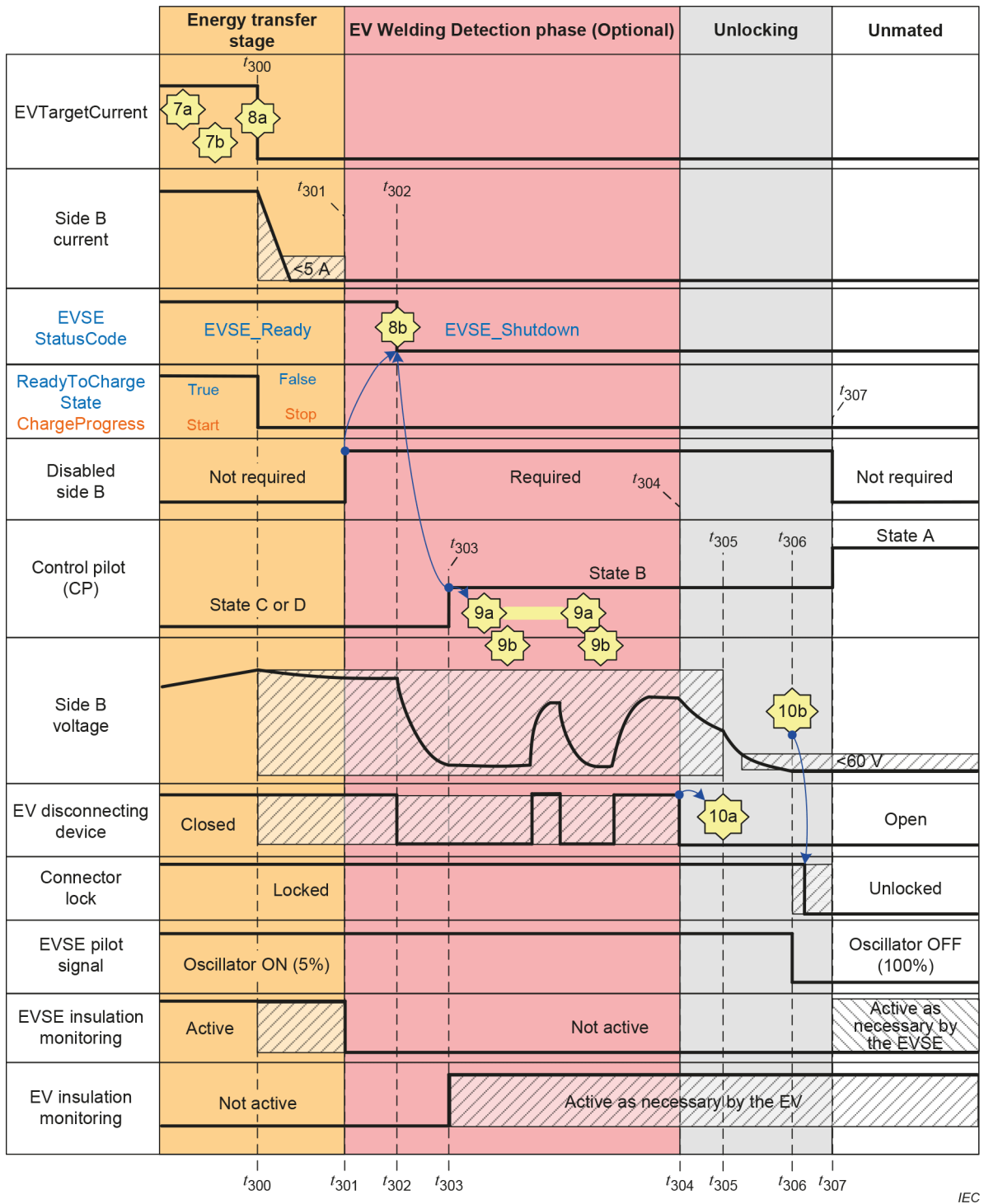

**Figure CC.7 – Sequence diagram for EV supply equipment and EV initiated error shutdown**

**Table CC.11 – Sequence description for EV supply equipment and EV initiated error shutdown**

Timestamp	Description
► t200	<ul style="list-style-type: none"> <li>General pre-condition: Any digital communication messages between the EV and EVSE.</li> <li>Preconditions for EV initiated error shutdown: CP state B, C or D.</li> <li>Preconditions for EVSE initiated error shutdown: CP oscillator ON.</li> </ul>
t200	<ul style="list-style-type: none"> <li>Occurrence of error shutdown condition detected by the EV or EVSE (for example, the EV triggers an error shutdown via digital communication, digital communication loss or closing of the data link/TCP connection). See Table CC.10.</li> </ul> <p>NOTE 1 When using DIN SPEC 70121:2014, if an error condition occurs before energy transfer, the EV proceeds to t305 in Table CC.12, by sending a SessionStopReq &lt;10a&gt; message.</p> <p>NOTE 2 When using DIN SPEC 70121:2014, if an error condition occurs during energy transfer, the EV proceeds to t300 in Table CC.12, by sending a PowerDeliveryReq &lt;8a&gt; message.</p> <ul style="list-style-type: none"> <li>The trigger time starts from this moment.</li> </ul> <p>NOTE 3 Some trigger times for EV initiated error shutdown depends on digital communication requirements. See IEC 61851-24.</p> <p>For an EV initiated error shutdown:</p> <ul style="list-style-type: none"> <li>The EV may open the EV disconnection device. In this case, the EV shall not re-close the EV disconnection device.</li> </ul>
t200 ► t201	<ul style="list-style-type: none"> <li>Duration of the trigger time of the EVSE. See CC.3.4 for the specific requirements for each error shutdown.</li> </ul>
t201	<ul style="list-style-type: none"> <li>The EVSE performs the error shutdown.</li> <li>The timing requirements of 6.3.1.113.3 (performance time) starts from this moment.</li> <li>The EVSE shall disable the EVSE IMD, if not already done.</li> </ul>
t201 ► t202	<ul style="list-style-type: none"> <li>The EVSE shall reduce the present current at side B to &lt; 5 A DC and disable side B in 1 s or less, if not already done.</li> </ul>
t201 ► t206	<ul style="list-style-type: none"> <li>The EVSE shall, in 2,5 s or less, reduce the present voltage at side B to ≤ 60 V DC between <ul style="list-style-type: none"> <li>DC+ and DC–,</li> <li>DC+ and PE, and</li> <li>DC– and PE.</li> </ul> </li> </ul>
t202	<ul style="list-style-type: none"> <li>The present current at side B shall be &lt; 5 A DC and remain &lt; 5 A DC.</li> <li>If not already done, the EVSE shall stop the overvoltage protection according to 6.3.1.106, and then, the EVSE shall disable side B, and open the EVSE disconnection device, if any.</li> </ul> <p>During an EVSE initiated error shutdown:</p> <ul style="list-style-type: none"> <li>If digital communication is still operational, the EVSE shall send parameter "ResponseCode" = 'FAILED' in the next response messages. See IEC 61851-24:2023.</li> </ul> <p>During an EV initiated error shutdown:</p> <ul style="list-style-type: none"> <li>If digital communication is still operational, the EVSE shall send message SessionStopRes &lt;10b&gt; if message SessionStopReq &lt;10a&gt; was received before t202.</li> </ul> <p>NOTE 4 See ISO 15118-2:2014 and DIN SPEC 70121:2014 for exception cases, if any.</p>
t202 ► t203	<ul style="list-style-type: none"> <li>The EVSE shall turn off its CP oscillator between 300 ms and 500 ms after the present current at side B is &lt; 5 A DC.</li> </ul>
t202 ► t207	<ul style="list-style-type: none"> <li>The disabled side B of the EVSE shall have equivalent electrical properties/behaviour (for example, impedance, discharge rate, etc.) as the circuit described in CC.2.4.</li> </ul>
t203	<ul style="list-style-type: none"> <li>The EVSE shall turn off its CP oscillator.</li> </ul> <p>If the EVSE turns off the CP oscillator before sending a response message with parameter "ResponseCode" = 'FAILED', the EV will detect an EVSE initiated emergency shutdown (see 6.3.1.113.3). The 300 ms delay should be sufficient for the EV to send and receive the digital communication message.</p> <ul style="list-style-type: none"> <li>If the EVSE has not turned off its CP oscillator 2,5 s after the error is detected (t200), the EV and EVSE shall trigger an emergency shutdown. See 6.3.1.113.3 for the timing requirements for the EVSE regarding the present current at side B, disconnection device and CP oscillator.</li> </ul>

Timestamp	Description
t203 ► t204	<ul style="list-style-type: none"> <li>The EV shall open the EV disconnection device in 100 ms or less after the EVSE has turned off its CP oscillator.</li> </ul>
t204	<ul style="list-style-type: none"> <li>The EV shall open the EV disconnection device, if not already open.</li> </ul>
t205	<ul style="list-style-type: none"> <li>The EV shall change the CP state to B when it has opened the EV disconnection device.</li> <li>The EV may enable the EV IMD.</li> </ul>
t206	<ul style="list-style-type: none"> <li>The present voltage at side B between DC+ and DC– shall be <math>\leq 60</math> V DC.</li> </ul> <p>During an EV initiated error shutdown:</p> <ul style="list-style-type: none"> <li>If digital communication is still operational, the EVSE shall send message SessionStopRes &lt;10b&gt; if message SessionStopReq &lt;10a&gt; was received after t202.</li> </ul> <p>NOTE 5 See ISO 15118-2:2014 and DIN SPEC 70121:2014 for exception cases, if any.</p>
t206 ► t207	<ul style="list-style-type: none"> <li>If digital communication is still operational, the EV should unlock the vehicle connector after the SessionStopRes &lt;10b&gt; message is received. The requirements for unlocking are defined in ISO 17409.</li> <li>Any subsequent re-initiation of a new communication session shall use the restart sequence as specified in CC.5.2 and continue to t1 in the normal startup sequence CC.3.2.</li> </ul>
t207	<ul style="list-style-type: none"> <li>Un-mating the vehicle connector changes the CP state from B to A.</li> <li>The limitations of the disabled side B of the EVSE are not required.</li> </ul>



**Figure CC.8 – Sequence diagram for EV initiated error shutdown based on DIN SPEC 70121 during energy transfer**

**Table CC.12 – Sequence description for EV initiated error shutdown based on DIN SPEC 70121 during energy transfer**

Timestamp	Description
► t300	<ul style="list-style-type: none"> <li>Cyclic CurrentDemandReq/Res messages between the EV &lt;7a&gt; and EVSE &lt;7b&gt;.</li> </ul>
t300	<ul style="list-style-type: none"> <li>An EV, using DIN SPEC 70121:2014 as its digital communication protocol, triggers an EV initiated error shutdown by requesting the EVSE to disable side B by sending message PowerDeliveryReq &lt;8a&gt; with parameter "ReadyToChargeState" = 'FALSE'.</li> </ul>
t300 ► t301	<ul style="list-style-type: none"> <li>If the present current at side B is &gt; 5 A DC, the present current at side B shall be &lt; 5 A DC in 1 s or less and remain &lt; 5 A DC.</li> </ul>
t300 ► t303	<ul style="list-style-type: none"> <li>The EV may open the EV disconnection device after the present current is &lt; 5 A DC and after the message PowerDeliveryReq &lt;8a&gt; has been sent. In this case, the EV shall not re-close the EV disconnection device.</li> </ul>
t301	<ul style="list-style-type: none"> <li>If not already done, the EVSE shall stop the overvoltage protection according to 6.3.1.106, and then, the EVSE shall disable side B, and open the EVSE disconnection device, if any.</li> </ul> <p>NOTE 1 If the EVSE disables side B while the present current at side B is &gt; 0 A DC, the present voltage at side B drops to the battery system voltage because the EV disconnection device is still closed.</p> <ul style="list-style-type: none"> <li>The EVSE shall disable the EVSE IMD.</li> </ul>
t301 ► t307	<ul style="list-style-type: none"> <li>The disabled side B of the EVSE shall have equivalent electrical properties/behaviour (for example, impedance, discharge rate, etc.) as the circuit described in CC.2.4.</li> </ul>
t302	<ul style="list-style-type: none"> <li>The EVSE shall communicate that the present current at side B is &lt; 5 A DC and has disabled side B by sending parameter "EVSEStatusCode" = 'EVSE_Shutdown' in message PowerDeliveryRes &lt;8b&gt;.</li> </ul>
t302 ► t305	<ul style="list-style-type: none"> <li>If the EVSE has not received a SessionStopReq &lt;10a&gt; message 20 s after sending the PowerDeliveryRes &lt;8b&gt; message, the EVSE shall trigger an EVSE initiated error shutdown.</li> </ul>
t303	<ul style="list-style-type: none"> <li>The EV shall change the CP state to B after receiving message PowerDeliveryRes &lt;8b&gt;.</li> <li>The EV may enable the EV IMD, if any.</li> </ul> <p>NOTE 2 If the EV decides not to perform welding detection, it proceeds to t304.</p>
t303 ► t304	<ul style="list-style-type: none"> <li>The EV may actuate the EV disconnection device multiple times during welding detection.</li> <li>The EV may send multiple WeldingDetectionReq &lt;9a&gt; messages in order to read the present voltage at side B measured by the EVSE in the WeldingDetectionRes &lt;9b&gt; messages.</li> <li>The EVSE shall check if the CP state changed to state B before sending the first WeldingDetectionRes &lt;9b&gt; message.</li> </ul>
t304	<ul style="list-style-type: none"> <li>The EV completes welding detection, if performed.</li> <li>The EV shall open the EV disconnection device.</li> </ul> <p>NOTE 3 The opening of the EV disconnection device starts the reduction of the present voltage at side B by passive discharge because the EVSE has not yet received message SessionStopReq &lt;10a&gt;.</p>
t305	<ul style="list-style-type: none"> <li>The EV shall send the SessionStopReq &lt;10a&gt; message after it has opened the EV disconnection device.</li> <li>The EV initiates digital communication termination by sending message SessionStopReq &lt;10a&gt;.</li> </ul>
t305 ► t306	<ul style="list-style-type: none"> <li>The EVSE shall, in 1 s or less, reduce the present voltage at side B between DC+ and DC– to ≤ 60 V DC.</li> </ul> <p>NOTE 4 The EVSE can actively discharge side B because the EV has opened the EV disconnection device.</p>
t306	<ul style="list-style-type: none"> <li>The EVSE shall send the message SessionStopRes &lt;10b&gt;.</li> <li>The EVSE shall turn off its CP oscillator according to IEC 61851-24.</li> </ul>
t306 ► t307	<ul style="list-style-type: none"> <li>The EV should unlock the vehicle connector after the SessionStopRes &lt;10b&gt; message is received. The requirements for unlocking are defined in ISO 17409.</li> <li>Any subsequent re-initiation of a new communication session shall use the restart sequence as specified in CC.5.2 and continue to t1 in the normal startup sequence CC.3.2.</li> </ul>
t307	<ul style="list-style-type: none"> <li>Un-mating the vehicle connector changes the CP state from B to A.</li> <li>The limitations of the disabled side B of the EVSE are not required.</li> </ul>

#### **CC.3.4.3 Emergency shutdown executed by the EV or the EV supply equipment**

The sequence and description of an emergency shutdown executed by the EV are shown in Figure CC.9 and Table CC.13.

The sequence and description of an emergency shutdown executed by the EV supply equipment are shown in Figure CC.10 and Table CC.14.

Both the EV supply equipment and the EV must communicate, by means of basic signalling, that an emergency shutdown condition was detected. In this case, the EV supply equipment and the EV execute the emergency shutdown independently, synchronized with basic signalling.

The diagrams show multiple scenarios for emergency shutdown conditions, as detected by the EV supply equipment or EV.

After the completion of an emergency shutdown, the EV shall not induce voltages at side B more than the values specified in 6.3.1.113.4.

**NOTE** The EV cannot enter the welding detection phase, nor can it perform a welding detection based on voltages at side B more than the values specified in 6.3.1.113.4.

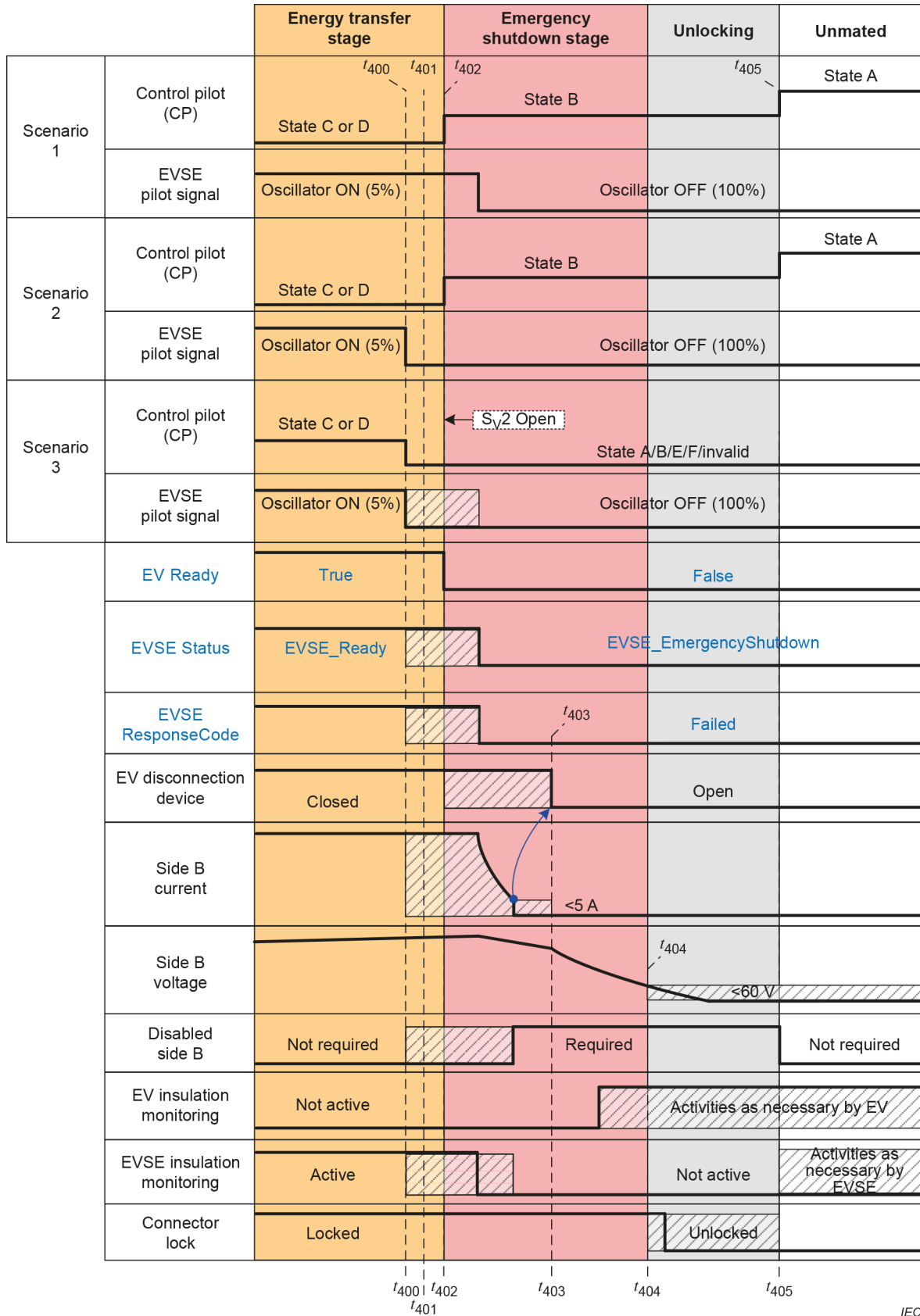
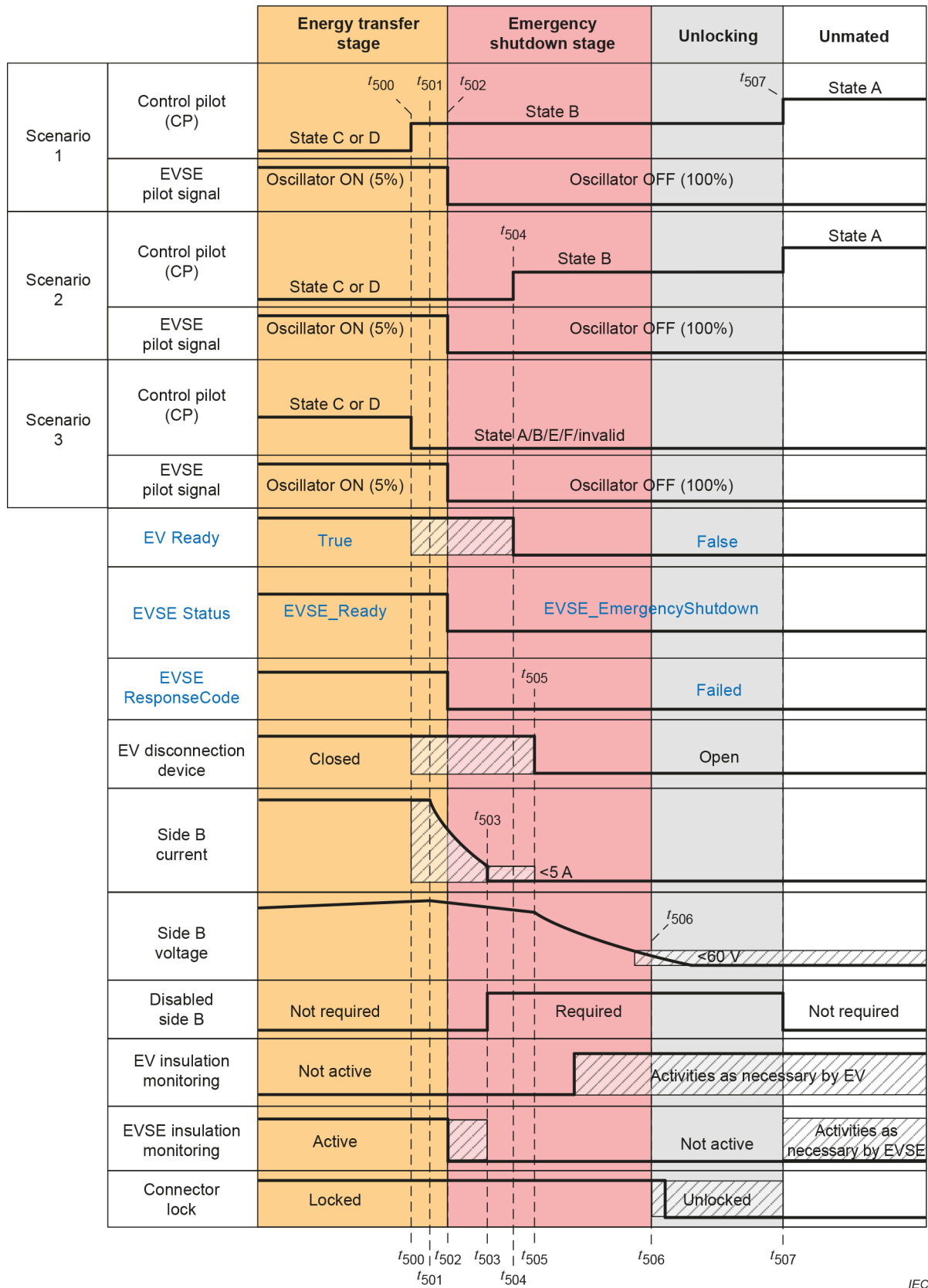

Figure CC.9 – Sequence diagram for an emergency shutdown executed by the EV

**Table CC.13 – Sequence diagram an emergency shutdown executed by the EV**

Timestamp	Description
▶ t400	<ul style="list-style-type: none"> <li>General pre-condition: Any digital communication messages between the EV and EVSE.</li> <li>Pre-conditions for emergency shutdowns executed by the EV: CP state C/D and CP oscillator on (5 % PWM)</li> </ul>
t400	<ul style="list-style-type: none"> <li>Occurrence of the first emergency shutdown condition: <ul style="list-style-type: none"> <li>Scenario 1: Occurrence of a fault that can be detected by the EV (for example, internal fault of the EV, loss of electrical continuity of the protective conductor without leaving CP state C or D, etc). The fault has not been detected by the EVSE.</li> <li>Scenario 2: The EVSE initiates an emergency shutdown by turning off the CP oscillator (100 % PWM). The fault has not been detected by the EV.</li> <li>Scenario 3: Occurrence of a fault detected by both the EV and EVSE. For example, when <math>S_{\sqrt{2}}</math> is closed and the CP state changes to states A/B/E/F or Invalid from the EV perspective (for example, loss of electrical continuity of the control pilot conductor or loss of electrical continuity of the proximity detection conductor).</li> </ul> </li> </ul> <p>When the EV detects an emergency shutdown condition, it shall not rely on digital communication from the EVSE, as a fault condition may disturb digital communication or basic signalling between the EV and EVSE.</p> <p>NOTE 1 The timing requirements in this sequence are based on the occurrence of the first emergency shutdown condition detected by the EV. There might be subsequent emergency shutdown conditions.</p>
t400 ▶ t401	<p>Scenario 1:</p> <ul style="list-style-type: none"> <li>In case the EV detects an internal fault, the EV shall open <math>S_{\sqrt{2}}</math> as specified by the EV manufacturer.</li> <li>In case of losing of electrical continuity of the protective conductor without leaving CP state C or D (from point A to the EV, see Figure CC.1 and Figure CC.2), the EV shall trigger an emergency shutdown in 150 ms or less. See CC.4.7.</li> </ul> <p>Scenario 2:</p> <ul style="list-style-type: none"> <li>In case the EVSE turned off the CP oscillator, the EV shall trigger an emergency shutdown in 50 ms or less.</li> </ul> <p>Scenario 3:</p> <ul style="list-style-type: none"> <li>In case of an unexpected CP state change, the EV shall trigger an emergency shutdown in 50 ms or less. See CC.4.3.</li> </ul>
t401	<ul style="list-style-type: none"> <li>The EV triggers the emergency shutdown.</li> </ul>
t401 ▶ t402	<ul style="list-style-type: none"> <li>The EV shall open <math>S_{\sqrt{2}}</math> in 10 ms or less.</li> </ul>
t402	<ul style="list-style-type: none"> <li>The EV opens <math>S_{\sqrt{2}}</math>.</li> <li>The EV may open the EV disconnection device. In this case, the EV shall not re-close the EV disconnection device.</li> </ul>
t401 ▶ t403	<ul style="list-style-type: none"> <li>The EV shall either <ul style="list-style-type: none"> <li>open the EV disconnection device in 100 ms or less after the present current at side B is &lt; 5 A DC, or</li> <li>open the EV disconnection device 1,1 s after triggering an emergency shutdown, whichever results in the shortest time to open the EV disconnection device.</li> </ul> </li> </ul> <p>NOTE 2 In an emergency shutdown, the EVSE has reduced the present current at side B to &lt; 5 A DC in 30 ms or less after t401. The EV has sufficient time to open the EV disconnection device without a present current at side B.</p> <p>NOTE 3 Legacy EVSEs, according to IEC 61851-23:2014, can take up to 1 s to reduce the present current at side B to &lt; 5 A DC in case the CP state changes from state C/D to state B.</p>
t401 ▶ t405	<ul style="list-style-type: none"> <li>Both the EV and EVSE may try to maintain digital communication.</li> <li>If the EV or EVSE send a digital communication message, the request message sent by the EV shall contain parameter "EVReady" = 'False'.</li> </ul>
t403	<ul style="list-style-type: none"> <li>The EV opens the EV disconnection device.</li> </ul>
t403 ▶	<ul style="list-style-type: none"> <li>The EV may enable the EV IMD, if any.</li> </ul>

Timestamp	Description
t404	<ul style="list-style-type: none"> <li>• See t505 in Table CC.14 (emergency shutdown executed by the EVSE)</li> </ul>
t404 ► t405	<ul style="list-style-type: none"> <li>• The EV may unlock the vehicle connector. The requirements for unlocking are defined in ISO 17409.</li> <li>• Any subsequent re-initiation of a new communication session shall use the restart sequence as specified in CC.5.2 and continue to t1 in the normal startup sequence CC.3.2.</li> </ul>
t405	<ul style="list-style-type: none"> <li>• Un-mating the vehicle connector changes the CP state from B to A.</li> </ul>



**Figure CC.10 – Sequence diagram for an emergency shutdown executed by the EV supply equipment**

**Table CC.14 – Sequence diagram an emergency shutdown executed by the EV supply equipment**

Timestamp	Description
▶ t500	<ul style="list-style-type: none"> <li>General pre-condition: Any digital communication messages between the EV and EVSE.</li> <li>Pre-condition for an emergency shutdown executed by the EVSE: CP oscillator on.</li> </ul>
t500	<ul style="list-style-type: none"> <li>Occurrence of the first emergency shutdown condition:                             <ul style="list-style-type: none"> <li>Scenario 1: The EV initiates an emergency shutdown by opening <math>S_{V2}</math> (for example, internal fault of the EV, loss of electrical continuity of the protective conductor without leaving CP state C or D, etc.). The fault has not been detected by the EVSE.</li> <li>Scenario 2: Occurrence of a fault that can be detected by the EVSE (for example, internal fault detected by EVSE). The fault has not been detected by the EV.</li> <li>Scenario 3: Occurrence of a fault detected by both the EV and EVSE. For example, the CP state changes to states A/B/E/F or Invalid from the EVSE perspective (for example, loss of electrical continuity of the protective conductor, loss of electrical continuity of the control pilot conductor or loss of electrical continuity of the proximity detection conductor).</li> </ul> </li> </ul> <p>When the EVSE detects an emergency shutdown condition, it shall not rely on digital communication from the EV, as a fault condition can disturb digital communication or basic signalling between the EV and EVSE.</p> <p>NOTE 1 The timing requirements in this sequence are based on the occurrence of the first emergency shutdown condition detected by the EVSE. There might be subsequent emergency shutdown conditions.</p> <p>In an emergency shutdown executed by the EV (scenario 1), the EV may open the EV disconnection device as soon as it detected the fault condition.</p>
t500 ▶ t501	<ul style="list-style-type: none"> <li>The EVSE shall trigger an emergency shutdown in the trigger times or less specified for each fault. See Table CC.10.</li> <li>In case the EVSE detects an internal fault not specified in Table CC.10, the EVSE shall trigger an emergency shutdown as specified by the EVSE manufacturer.</li> </ul> <p>NOTE 2 The trigger time is the time between the occurrence of a fault and the moment that an emergency has to be triggered by the EVSE. These times are specified for each fault in Table CC.10.</p>
t501	<ul style="list-style-type: none"> <li>The EVSE has triggered an emergency shutdown.</li> </ul> <p>NOTE 4 Point in time that cannot be physically measured at the vehicle connector.</p>
t501 ▶ t502	<ul style="list-style-type: none"> <li>The EVSE shall turn off its CP oscillator in 10 ms or less.</li> </ul>
t501 ▶ t503	<ul style="list-style-type: none"> <li>The EVSE shall reduce the present current at side B to &lt; 5 A DC and disable side B in 20 ms or less, if not already done. See 6.3.1.113.4.</li> </ul>
t501 ▶ t506	<ul style="list-style-type: none"> <li>The EVSE shall, in 1 s or less, reduce the present voltage at side B to <math>\leq 60</math> V DC between                             <ul style="list-style-type: none"> <li>DC+ and DC–,</li> <li>DC+ and PE, and</li> <li>DC– and PE.</li> </ul> </li> </ul>
t502	<ul style="list-style-type: none"> <li>The EVSE turns off its CP oscillator to indicate an EVSE initiated emergency shutdown.</li> </ul> <p>NOTE 5 The timing requirements of 6.3.1.113.4 (performance time) start from this moment.</p> <ul style="list-style-type: none"> <li>The EVSE shall disable the EVSE IMD, if not already done.</li> </ul>
t502 ▶ t504	<p>Scenario 2:</p> <ul style="list-style-type: none"> <li>The EV shall change the CP state from C/D to B by opening <math>S_{V2}</math> in 50 ms or less after the CP oscillator is turned off.</li> </ul>
t502 ▶ t507	<ul style="list-style-type: none"> <li>Both the EV and EVSE may try to maintain digital communication.</li> <li>If the EV or EVSE send a digital communication message, the response message sent by the EVSE shall contain parameter "ResponseCode" = 'FAILED'.</li> </ul>
t503	<ul style="list-style-type: none"> <li>The EVSE has reduced the present current at side B to &lt; 5 A DC.</li> <li>If not already done, the EVSE shall stop the overvoltage protection according to 6.3.1.106, and then, the EVSE shall disable side B, and open the EVSE disconnection device, if any.</li> </ul>
t503 ▶ t507	<ul style="list-style-type: none"> <li>The disabled side B of the EVSE shall have equivalent electrical properties/behaviour (for example, impedance, discharge rate, etc.) as the circuit described in CC.2.4.</li> </ul>

Timestamp	Description
t504	Scenario 2: <ul style="list-style-type: none"> <li>The EV opens <math>S_{\sqrt{2}}</math>. See t402 in Table CC.13 (emergency shutdown executed by the EV).</li> </ul>
t505	<ul style="list-style-type: none"> <li>See t403 in Table CC.13 (emergency shutdown executed by the EV).</li> </ul> <p>NOTE 6 The EVSE can assume the EV opened the EV disconnection device 160 ms after turning off the CP oscillator or after the CP state changed from state C/D to states A/BCE/F or Invalid. After this time, the EVSE can proceed to actively discharge side B.</p>
t506	<ul style="list-style-type: none"> <li>The present voltage at side B between DC+ and DC– is <math>\leq 60</math> V DC.</li> </ul>
t506 ► t507	<ul style="list-style-type: none"> <li>See t404 ► t405 in Table CC.13 (emergency shutdown executed by the EV)</li> <li>Any subsequent re-initiation of a new communication session shall use the restart sequence as specified in CC.5.2 and continue to t1 in the normal startup sequence CC.3.2.</li> </ul>
t507	<ul style="list-style-type: none"> <li>Un-mating the vehicle connector changes the CP state from B to A.</li> <li>The limitations of the disabled side B of the EVSE are not required.</li> </ul>

### CC.3.5 Pause by EV supply equipment using ISO 15118-2:2014

#### CC.3.5.1 General

The sequences specified in CC.3.5 are only applicable for EV supply equipment using ISO 15118-2:2014.

#### CC.3.5.2 Pause before cable-check phase executed by EV supply equipment using ISO 15118-2:2014

If the EV supply equipment does not have power available at the beginning of the communication session to perform the cable-check phase, pre-charge phase and energy transfer stage, the EV supply equipment can perform a pause before cable-check phase. The EV supply equipment will trigger a restart of the communication session as soon as it has power available. This sequence is only applicable for ISO 15118-2:2014.

The sequence and description of pause before cable-check phase executed by the EV supply equipment are shown in Figure CC.11 and Table CC.15.

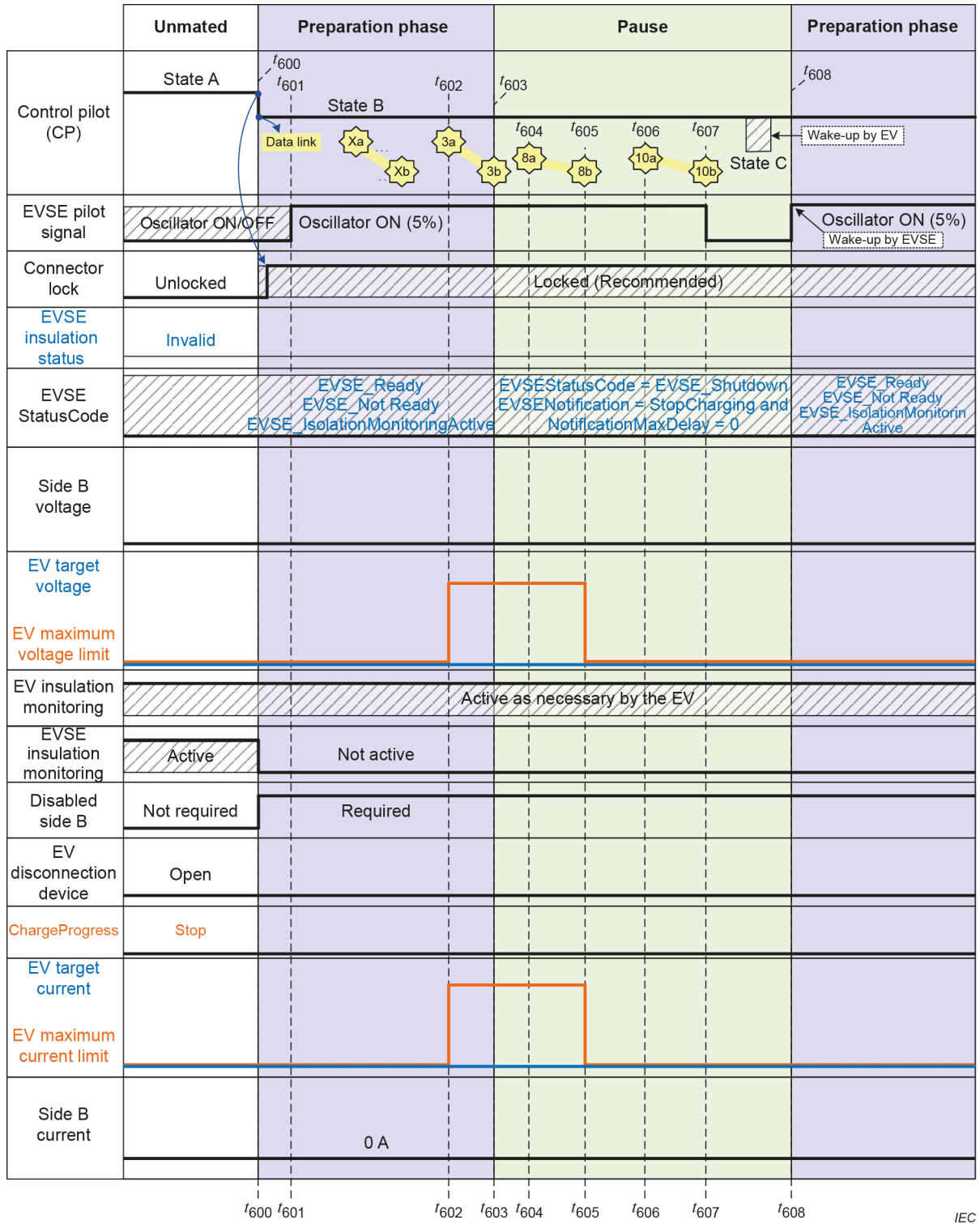

Figure CC.11 – Sequence diagram for pause before cable-check phase by EV supply equipment using ISO 15118-2:2014

**Table CC.15 – Sequence description for pause before cable-check phase by EV supply equipment using ISO 15118-2:2014**

Timestamp	Description
▶ t600	<ul style="list-style-type: none"> <li>The present voltage at side B shall be <math>\leq 60</math> V DC according to 6.3.1.113.1.</li> </ul>
t600	<ul style="list-style-type: none"> <li>The vehicle connector is mated to the vehicle inlet, which changes the CP state from A to B.</li> <li>After the CP state changed to B and the PP is detected (<math>S_3</math> closed in case of configuration EE), the EV should lock the vehicle connector in the vehicle inlet.</li> <li>After the CP state changed to B, the EVSE shall disable the EVSE IMD, disable side B and open the EVSE disconnection device, if any.</li> <li>After the CP state changed to B, the EV may try to set up a data link as defined in IEC 61851-24.</li> </ul>
t600 ▶ t603	<ul style="list-style-type: none"> <li>The EVSE shall not trigger an error shutdown due to the present voltage at side B (including negative voltages).</li> </ul> <p>When the vehicle connector is mated to the vehicle inlet, these voltages can be caused by the EV requirements for unmated conditions in ISO 17409:2020, 6.5.2. EV supply equipment based on IEC 61851-23:2014 shall trigger a shutdown if the present voltage at side B is <math>&gt; 60</math> V DC in the first ChargeParameterDiscoveryReq &lt;3a&gt; message.</p>
t600 ▶ t604	<ul style="list-style-type: none"> <li>If the EV tried and failed to lock the vehicle connector, the EV shall notify the EVSE with parameter "EVErrorCode" = 'FAILED_ChargerConnectorLockFault' in the next communicated message that contains this parameter, according to IEC 61851-24.</li> </ul>
t600 ▶ t608	<ul style="list-style-type: none"> <li>The disabled side B of the EVSE shall have equivalent electrical properties/behaviour (for example, impedance, discharge rate, etc.) as the circuit described in CC.2.4.</li> <li>The EVSE shall not perform the overvoltage protection according to 6.3.1.106.</li> </ul>
t601	<ul style="list-style-type: none"> <li>The EVSE shall turn on its CP oscillator if the EVSE is ready for energy transfer and if its CP oscillator is not already on.</li> <li>The EVSE shall maintain a CP duty cycle of 5 % from the start of the data link setup until end of communication session, unless a certain condition requires a different CP duty cycle.</li> </ul>
t601 ▶ t602	<ul style="list-style-type: none"> <li>The EV shall establish the data link as defined in IEC 61851-24 after it has verified that the EVSE has turned on its CP oscillator, if the data link is not already established.</li> </ul> <p>NOTE 1 The data link could have been previously established due to a pause or renegotiation of the communication session.</p> <ul style="list-style-type: none"> <li>Digital communication starts by the negotiation of an appropriate application layer protocol between the EV &lt;Xa&gt; and EVSE &lt;Xb&gt;. See Table CC.6.</li> <li>The EV and EVSE exchange message pairs concerning session setup, services, authentication, payment options and value-added services (if supported by the negotiated application layer protocol). According to IEC 61851-24, some message pairs are not necessary after a pause or renegotiation, for example, authentication or payment options.</li> </ul>
t602	<ul style="list-style-type: none"> <li>The EV shall send parameters "EVMaximumVoltageLimit" and "EVMaximumCurrentLimit" (amongst other parameters) with the first ChargeParameterDiscoveryReq &lt;3a&gt; message.</li> </ul>

Timestamp	Description
<p>t602 ► t603</p>	<ul style="list-style-type: none"> <li>• The EVSE shall perform a compatibility check. See CC.5.6.</li> <li>• The EVSE shall check if the absolute value of the present voltage at side B between DC+ and DC– is &lt; 60 V DC and shall send message ChargeParameterDiscovery &lt;3b&gt; with parameter "EVSEProcessing" = 'Ongoing' if the absolute value of the present voltage at side B is ≥ 60 V DC.</li> <li>• The EVSE shall send parameters "EVSEMaximumVoltageLimit", "EVSEMinimumVoltageLimit", "EVSEMaximumCurrentLimit" and "EVSEMinimumCurrentLimit" (amongst other parameters) in message ChargeParameterDiscoveryRes &lt;3b&gt; considering the compatibility check. See CC.5.6 on how to calculate these values.</li> </ul> <hr/> <ul style="list-style-type: none"> <li>• The EVSE shall send parameter "EVSEStatusCode" = 'EVSE_IsolationMonitoringActive' in the "ChargeParameterDiscoveryRes &lt;3b&gt;" messages, unless the EVSE wants to perform a shutdown. The EV is recommended to continue the communication session if the EVSE sends ChargeParameterDiscoveryRes &lt;3b&gt; messages with parameter "EVSE_StatusCode" = 'EVSE_Ready' or 'EVSE_NotReady'.</li> </ul> <p>NOTE 2 EVSEs based on IEC 61851-23:2014 can send parameter "EVSE_StatusCode" = "EVSE_Ready", "EVSE_NotReady", or "EVSE_IsolationMonitoringActive" in ChargeParameterDiscoveryRes &lt;3b&gt; messages.</p> <ul style="list-style-type: none"> <li>• If the EVSE replies with parameters "ResponseCode" = 'OK' and "EVSEProcessing" = 'Ongoing' in message ChargeParameterDiscoveryRes &lt;3b&gt;, the EV and EVSE may update the parameters sent in the next ChargeParameterDiscoveryReq/Res messages.</li> </ul> <p>NOTE 3 The EVSE can use "EVSEProcessing" = 'Ongoing' for other reasons. Example: load management, etc.</p> <ul style="list-style-type: none"> <li>• If the EV sends parameter "EVErrorCode" = 'FAILED_ChargerConnectorLockFault' in a ChargeParameterDiscoveryReq &lt;3a&gt; message, the EVSE should respond with cyclic ChargeParameterDiscoveryRes &lt;3b&gt; messages with parameters "EVSEProcessing" = 'Ongoing' and "ResponseCode" = 'OK' to give the EV additional time to solve the fault in the locking mechanism. See CC.5.6 for additional conditions for the EV supply equipment to send "EVSEProcessing" = 'Ongoing' during cyclic ChargeParameterDiscoveryReq/Res messages.</li> </ul> <p>The EVSE should inform the user how to improve the locking process. For example, by indicating how to properly mate the vehicle connector in the vehicle inlet.</p> <ul style="list-style-type: none"> <li>• ISO 15118-2:2014 does not specify the possibility to update the parameters in subsequent ChargeParameterDiscoveryReq/Res messages; however, it is recommended for the EVSE not to perform a shutdown if the EV changes the parameters.</li> <li>• To improve interoperability, the EVSE shall tolerate the EV changing CP state to C/D during cyclic ChargeParameterDiscoveryReq/Res messages. If the EV changes back to CP state B, the EVSE shall trigger an EVSE initiated emergency shutdown. See CC.3.4.3.</li> </ul> <p>Requirement [V2G2-912] in ISO 15118-2:2014 and a similar requirement in outdated versions of SAE J1772 do not specify that the EV shall receive a ChargeParameterDiscoveryRe &lt;3b&gt; with parameter "EVSEProcessing" = "Finished" before changing the CP state from state B to state C/D, leading to this unwanted behaviour.</p>
<p>t603</p>	<ul style="list-style-type: none"> <li>• If the absolute value of the present voltage at side B is &lt; 60 V DC, the EVSE shall send the EV the result of the compatibility check and trigger for a communication session pause before cable-check phase in message ChargeParameterDiscoveryRes &lt;3b&gt; using parameters "EVSEStatusCode" = 'EVSE_IsolationMonitoringActive', "EVSEProcessing" = 'Finished', and             <ul style="list-style-type: none"> <li>– "ResponseCode" = 'OK', "EVSENotification" = 'StopCharging', and "NotificationMaxDelay" = '0' if the compatibility check was completed successfully and the EVSE has no power available, or</li> <li>– "ResponseCode" = 'Failed_WrongChargeParameter' if the compatibility check was completed and failed, triggering an EVSE initiated error shutdown.</li> </ul> </li> </ul> <p>NOTE 4 A ChargeParameterDiscoveryRes &lt;3b&gt; message with "ResponseCode" = 'Failed_WrongChargeParameter' and parameter "EVSEProcessing" = 'Ongoing', will trigger an EVSE initiated error shutdown. See error handling specifications for the digital communication standards in IEC 61851-24.</p> <p>If the absolute value of the present voltage at side B is not &lt; 60 V DC at the end of the compatibility check (based on the timing requirements of IEC 61851-24), the EVSE cannot send a ChargeParameterDiscoveryRes &lt;3b&gt; message with parameter "EVSEProcessing" = 'Finished'. In this case, the EV shall trigger an error shutdown.</p> <p>NOTE 5 EVSEs based on IEC 61851-23:2014 can send parameter "EVSE_StatusCode" = "EVSE_Ready", "EVSE_NotReady", or "EVSE_IsolationMonitoringActive" in ChargeParameterDiscoveryRes &lt;3b&gt; messages. The EV is recommended to continue the communication session if the EVSE sends ChargeParameterDiscoveryRes &lt;3b&gt; messages with parameter "EVSE_StatusCode" = 'EVSE_Ready' or 'EVSE_NotReady'.</p>

Timestamp	Description
t603 ► t604	<ul style="list-style-type: none"> <li>The EV may lock the vehicle connector in the vehicle inlet.</li> <li>The EV shall not send messages CableCheckReq &lt;4a&gt; and PreChargeReq &lt;5a&gt;.</li> </ul> <p>NOTE 6 The EV does not send messages CableCheckReq &lt;4a&gt; and PreChargeReq &lt;5a&gt; because the EVSE has indicated that it has no power available.</p>
t603 ► t607	<ul style="list-style-type: none"> <li>The EV shall not change to CP state C/D during the communication session pause.</li> </ul>
t603 ►	<ul style="list-style-type: none"> <li>The EVSE shall trigger an error shutdown if the present voltage at side B between DC+ and DC– is &lt; –60 V DC for 400 consecutive ms or more.</li> </ul>
t604	<ul style="list-style-type: none"> <li>The EV shall not send messages CableCheckReq &lt;4a&gt; and PreChargeReq &lt;5a&gt;, but instead the EV shall send message PowerDeliveryReq &lt;8a&gt; with "ChargeProgress" = 'Stop'.</li> </ul> <p>NOTE 7 The EV does not send messages CableCheckReq &lt;4a&gt; and PreChargeReq &lt;5a&gt;, as the EVSE has indicated that it has no power available.</p> <ul style="list-style-type: none"> <li>If the EV tried and failed to lock the vehicle connector, the EV shall trigger an EV initiated error shutdown with parameter "EVErrorCode" = 'FAILED_ChargerConnectorLockFault' in message PowerDeliveryReq &lt;6a&gt;.</li> </ul>
t605	<ul style="list-style-type: none"> <li>The EVSE shall send message PowerDeliveryRes &lt;8b&gt; with parameters "EVSEStatusCode" = 'EVSE_Shutdown', "EVSENotification" = 'StopCharging', and "NotificationMaxDelay" = '0'.</li> </ul>
t606	<ul style="list-style-type: none"> <li>The EV shall send message SessionStopReq &lt;10a&gt; with parameter "ChargingSession" = 'Pause'.</li> </ul>
t607	<ul style="list-style-type: none"> <li>The EVSE shall send message SessionStopRes &lt;10b&gt; according to IEC 61851-24.</li> <li>The EVSE shall turn off its CP oscillator according to IEC 61851-24.</li> </ul>
t607 ► t608	<ul style="list-style-type: none"> <li>Duration of the communication session pause.</li> <li>If the EV or EVSE want to stop the communication session, the EV or EVSE, respectively, shall end the pause by performing a restart (see CC.5.2), followed by a normal startup (see t1 ► t2 in Table CC.8) and then a normal shutdown (see CC.3.3).</li> <li>If the EV or EVSE want to resume the communication session, the EV or EVSE, respectively, shall end the pause by performing a restart (see CC.5.2) followed by a normal startup (see CC.3.2).</li> <li>If the vehicle connector is un-mated, the EVSE shall terminate the data link according to IEC 61851-24.</li> </ul>
t608	<ul style="list-style-type: none"> <li>The EVSE shall turn on its CP oscillator according to IEC 61851-24, to indicate to the EV that power is now available.</li> <li>The EVSE shall continue to t1 in the normal startup sequence CC.3.2.</li> </ul>

### CC.3.5.3 Pause after pre-charge phase and before energy transfer stage by EV supply equipment using ISO 15118-2:2014

In case the EV supply equipment has power available at the beginning of the communication session to perform cable-check phase and pre-charge phase but not energy transfer stage, the EV supply equipment can perform a pause after pre-charge phase and before energy transfer stage. This case allows the EV supply equipment to verify that the insulation value is valid before the pause. If the cable-check phase fails, the user is notified before the pause that the EV supply equipment is not safe and can proceed to another EV supply equipment. This sequence is specified for ISO 15118-2:2014.

The sequence and description of pause after pre-charge phase and before energy transfer stage executed by the EV supply equipment using ISO 15118-2:2014 are shown in Figure CC.12 and Table CC.16.

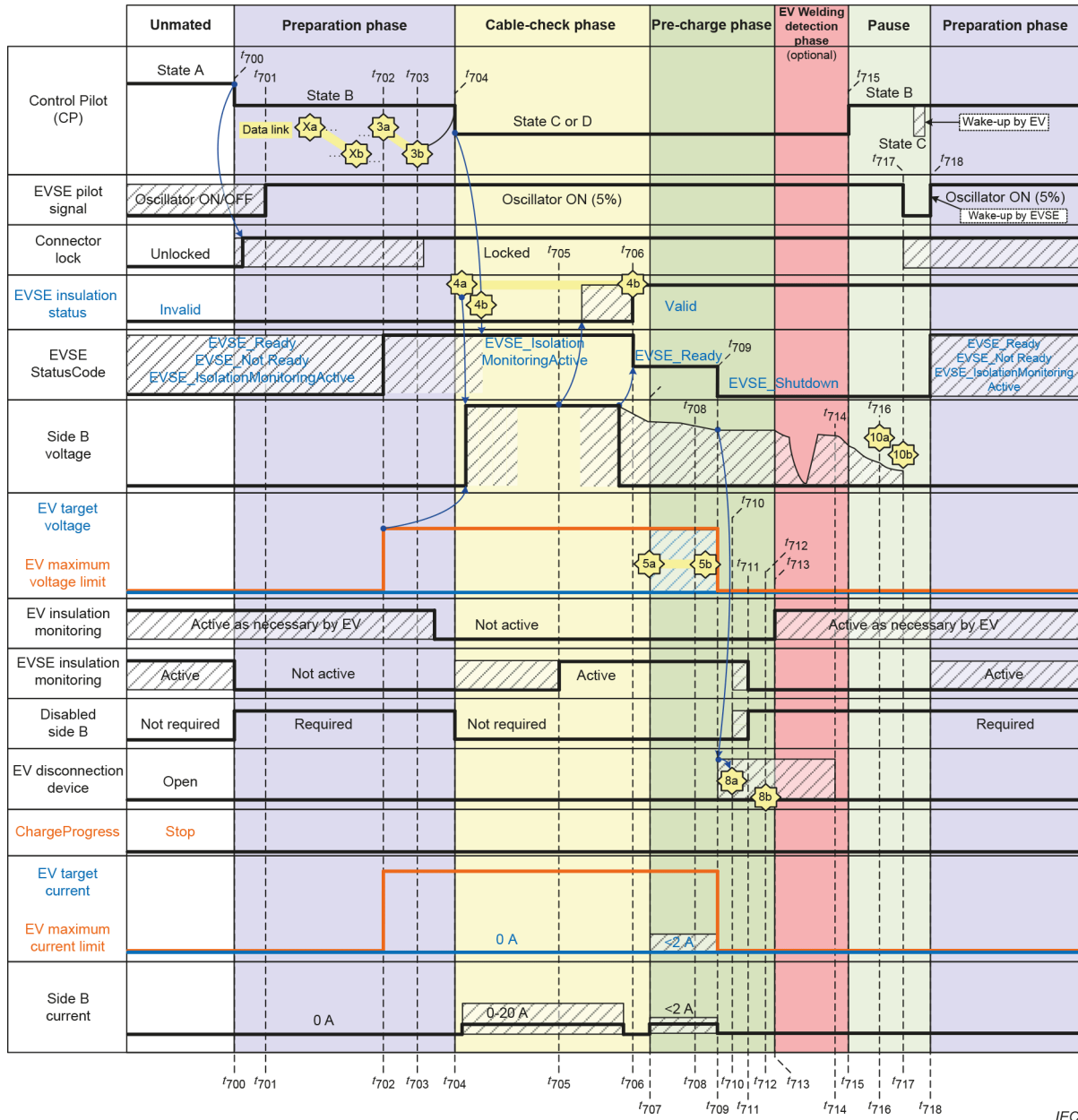

IEC

**Figure CC.12 – Sequence diagram for pause after pre-charge phase and before energy transfer stage by the EV supply equipment using ISO 15118-2:2014**

**Table CC.16 – Sequence description for pause after pre-charge phase and before energy transfer stage by the EV supply equipment using ISO 15118-2:2014**

Timestamp	Description
► t700	<ul style="list-style-type: none"> <li>The present voltage at side B shall be <math>\leq 60</math> V DC according to 6.3.1.113.1.</li> </ul>
t700	<ul style="list-style-type: none"> <li>The vehicle connector is mated to the vehicle inlet, which changes the CP state from A to B.</li> <li>After the CP state changed to B and the PP is detected (<math>S_{S3}</math> closed in case of configuration EE), the EV should lock the vehicle connector in the vehicle inlet.</li> <li>After the CP state changed to B, the EVSE shall disable the EVSE IMD, disable side B and open the EVSE disconnection device, if any.</li> <li>After the CP state changed to B, the EV may try to set up a data link as defined in IEC 61851-24.</li> </ul>
t700 ► t703	<ul style="list-style-type: none"> <li>The EVSE shall not trigger an error shutdown due to the present voltage at side B (including negative voltages).</li> </ul> <p>When the vehicle connector is mated to the vehicle inlet, these voltages can be caused by the EV requirements for unmated conditions in 6.5.2 of ISO 17409:2020. EV supply equipment based on IEC 61851-23:2014 shall trigger a shutdown if the present voltage at side B is <math>&gt; 60</math> V DC in the first ChargeParameterDiscoveryReq &lt;3a&gt; message.</p>
t700 ► t704	<ul style="list-style-type: none"> <li>If the EV tried and failed to lock the vehicle connector, the EV shall notify the EVSE with parameter "EVErrorCode" = 'FAILED_ChargerConnectorLockFault' in the next communicated message that contains this parameter, according to IEC 61851-24.</li> <li>The disabled side B of the EVSE shall have equivalent electrical properties/behaviour (for example, impedance, discharge rate, etc.) as the circuit described in CC.2.4.</li> </ul>
t700 ► t718	<ul style="list-style-type: none"> <li>The EVSE shall not perform the overvoltage protection according to 6.3.1.106.</li> </ul>
t701	<ul style="list-style-type: none"> <li>The EVSE shall turn on its CP oscillator if the EVSE is ready for energy transfer and if its CP oscillator is not already on.</li> <li>The EVSE shall maintain a CP duty cycle of 5 % from the start of the data link setup until end of communication session, unless a certain condition requires a different CP duty cycle.</li> </ul>
t701 ► t702	<ul style="list-style-type: none"> <li>The EV shall establish the data link as defined in IEC 61851-24 after it has verified that the EVSE has turned on its CP oscillator, if the data link is not already established.</li> </ul> <p>NOTE 1 The data link could have been previously established due to a pause or renegotiation of the communication session.</p> <ul style="list-style-type: none"> <li>Digital communication starts by the negotiation of an appropriate application layer protocol between the EV &lt;Xa&gt; and EVSE &lt;Xb&gt;. See Table CC.6.</li> <li>The EV and EVSE exchange message pairs concerning session setup, services, authentication, payment options and value-added services (if supported by the negotiated application layer protocol). According to IEC 61851-24, some message pairs are not necessary after a pause or renegotiation, for example, authentication or payment options.</li> </ul>
t702	<ul style="list-style-type: none"> <li>The EV shall send parameters "EVMaximumVoltageLimit" and "EVMaximumCurrentLimit" (amongst other parameters) with the first ChargeParameterDiscoveryReq &lt;3a&gt; message.</li> </ul>

Timestamp	Description
t702 ► t703	<ul style="list-style-type: none"> <li>• The EVSE shall perform a compatibility check. See CC.5.6.</li> <li>• The EVSE shall check if the absolute value of the present voltage at side B between DC+ and DC– is &lt; 60 V DC and shall send message ChargeParameterDiscovery &lt;3b&gt; with parameter "EVSEProcessing" = 'Ongoing' if the absolute value of the present voltage at side B is ≥ 60 V DC.</li> <li>• The EVSE shall send parameters "EVSEMaximumVoltageLimit", "EVSEMinimumVoltageLimit", "EVSEMaximumCurrentLimit" and "EVSEMinimumCurrentLimit" (amongst other parameters) in message ChargeParameterDiscoveryRes &lt;3b&gt; considering the compatibility check. See CC.5.6 on how to calculate these values.</li> <li>• The EVSE shall send parameter "EVSEStatusCode" = 'EVSE_IsolationMonitoringActive' in the "ChargeParameterDiscoveryRes &lt;3b&gt;" messages, unless the EVSE wants to perform a shutdown. The EV is recommended to continue the communication session if the EVSE sends ChargeParameterDiscoveryRes &lt;3b&gt; messages with parameter "EVSE_StatusCode" = 'EVSE_Ready' or 'EVSE_NotReady'.</li> </ul> <p>NOTE 2 EVSEs based on IEC 61851-23:2014 can send parameter "EVSE_StatusCode" = "EVSE_Ready", "EVSE_NotReady", or "EVSE_IsolationMonitoringActive" in ChargeParameterDiscoveryRes &lt;3b&gt; messages..</p> <ul style="list-style-type: none"> <li>• If the EVSE replies with parameters "ResponseCode" = 'OK' and "EVSEProcessing" = 'Ongoing' in message ChargeParameterDiscoveryRes &lt;3b&gt;, the EV and EVSE may update the parameters sent in the next ChargeParameterDiscoveryReq/Res messages.</li> </ul> <p>NOTE 3 The EVSE can use "EVSEProcessing" = 'Ongoing' for other reasons. Example: load management, etc.</p> <ul style="list-style-type: none"> <li>• If the EV sends parameter "EVErrrorCode" = 'FAILED_ChargerConnectorLockFault' in a ChargeParameterDiscoveryReq &lt;3a&gt; message, the EVSE should respond with cyclic ChargeParameterDiscoveryRes &lt;3b&gt; messages with parameters "EVSEProcessing" = 'Ongoing' and "ResponseCode" = 'OK' to give the EV additional time to solve the fault in the locking mechanism. See CC.5.6 for additional conditions for the EV supply equipment to send "EVSEProcessing" = 'Ongoing' during cyclic ChargeParameterDiscoveryReq/Res messages.</li> </ul> <p>The EVSE should inform the user how to improve the locking process. For example, by indicating how to properly mate the vehicle connector in the vehicle inlet.</p> <ul style="list-style-type: none"> <li>• ISO 15118-2:2014 does not specify the possibility to update the parameters in subsequent ChargeParameterDiscoveryReq/Res messages; however, it is recommended for the EVSE not to perform a shutdown if the EV changes the parameters.</li> <li>• To improve interoperability, the EVSE shall tolerate the EV changing CP state to C/D during cyclic ChargeParameterDiscoveryReq/Res messages. If the EV changes back to CP state B, the EVSE shall trigger an EVSE initiated emergency shutdown. See CC.3.4.3.</li> </ul> <p>Requirement [V2G2-912] in ISO 15118-2:2014 and a similar requirement in outdated versions of SAE J1772 do not specify that the EV shall receive a ChargeParameterDiscoveryRe &lt;3b&gt; with parameter "EVSEProcessing" = "Finished" before changing the CP state from state B to state C/D, leading to this unwanted behaviour.</p>

Timestamp	Description
t703	<ul style="list-style-type: none"> <li>• If the absolute value of the present voltage at side B is &lt; 60 V DC, the EVSE shall send the EV the result of the compatibility check and trigger for a communication session pause after pre-charge phase in message ChargeParameterDiscoveryRes &lt;3b&gt; using parameters "EVSEStatusCode" = 'EVSE_IsolationMonitoringActive', "EVSEProcessing" = 'Finished', and <ul style="list-style-type: none"> <li>– "ResponseCode" = 'OK', "EVSENotification" = 'StopCharging, and "NotificationMaxDelay" = 'X' (where X is different to 0) if the compatibility check was completed successfully and the EVSE has no power available, or</li> <li>– "ResponseCode" = 'Failed_WrongChargeParameter' if the compatibility check was completed and failed, triggering an EVSE initiated error shutdown.</li> </ul> </li> </ul> <p>NOTE 4 A ChargeParameterDiscoveryRes &lt;3b&gt; message with "ResponseCode" = 'Failed_WrongChargeParameter' and parameter "EVSEProcessing" = 'Ongoing', will trigger an EVSE initiated error shutdown. See error handling specifications for the digital communication standards in IEC 61851-24.</p> <p>If the absolute value of the present voltage at side B is not &lt; 60 V DC at the end of the compatibility check (based on the timing requirements of IEC 61851-24), the EVSE cannot send a ChargeParameterDiscoveryRes &lt;3b&gt; message with parameter "EVSEProcessing" = 'Finished'. In this case, the EV shall trigger an error shutdown.</p> <p>The EVSE shall consider its timings for cable-check phase and pre-charge phase to define the value for NotificationMaxDelay. A NotificationMaxDelay of 300 s is recommended.</p> <p>NOTE 5 EVSEs based on IEC 61851-23:2014 can send parameter "EVSE_StatusCode" = "EVSE_Ready", "EVSE_NotReady", or "EVSE_IsolationMonitoringActive" in ChargeParameterDiscoveryRes &lt;3b&gt; messages. The EV is recommended to continue the communication session if the EVSE sends ChargeParameterDiscoveryRes &lt;3b&gt; messages with parameter "EVSE_StatusCode" = 'EVSE_Ready' or 'EVSE_NotReady'.</p>
t703 ► t704	<ul style="list-style-type: none"> <li>• If the EV and EVSE are not compatible, the EV shall perform an EV initiated error shutdown. See CC.3.4.2.</li> <li>• The EV shall lock the vehicle connector in the vehicle inlet before changing the CP to state C or D, if not already locked.</li> <li>• If the EV failed to lock the vehicle connector, the EV shall trigger an EV initiated error shutdown with parameter "EVErrorCode" = 'FAILED_ChargerConnectorLockFault' in the next communicated message.</li> <li>• The EV shall disable the EV IMD, if any.</li> </ul>
t703 ►	<ul style="list-style-type: none"> <li>• The EVSE shall trigger an error shutdown if the present voltage at side B between DC+ and DC– is &lt; –60 V DC for 400 consecutive ms or more.</li> </ul>
t704	<ul style="list-style-type: none"> <li>• After the EV has disabled the EV IMD and after checking that the vehicle connector is locked, the EV shall change the CP state from B to C/D by closing <math>S_{\sqrt{2}}</math>.</li> </ul> <p>The common mode and differential mode influences from the EV at side B (for example, welding detection, IMD, etc) should be removed before the EV changes the CP state from B to C/D by closing <math>S_{\sqrt{2}}</math> because this can interfere with the IMD of the EVSE.</p> <ul style="list-style-type: none"> <li>• After the CP state changed to C/D, the EVSE shall enable side B. The limitations of the disabled side B of the EVSE are not required.</li> </ul>
t704 ► t705	<ul style="list-style-type: none"> <li>• After checking that the vehicle connector is locked, the EV shall request cable and insulation resistance check before pre-charge with CableCheckReq &lt;4a&gt;. See cable-check CC.4.1.2.</li> <li>• The EVSE shall check if the CP state changed to state C or D before sending the first CableCheckRes &lt;4b&gt; message and before the present voltage at side B between DC+ and DC– is &gt; 60 V DC.</li> </ul>
t704 ► t706	<ul style="list-style-type: none"> <li>• The EVSE shall check the functionality of the EVSE IMD. See CC.4.1.2 and CC.4.1.3.</li> <li>• The EVSE shall check the insulation of side B and continuously report the insulation state with parameter "EVSEIsolationStatus" according to CC.4.1.4, "EVSEProcessing" = 'Ongoing', and "EVSEStatusCode" = 'EVSE_IsolationMonitoringActive' in message CableCheckRes&lt;4b&gt;.</li> <li>• The EVSE may perform other functions (for example, welding detection) while sending parameters "EVSEIsolationStatus" according to CC.4.1.4 and "EVSEProcessing" = 'Ongoing' in message CableCheckRes&lt;4b&gt;.</li> </ul>
t705	<ul style="list-style-type: none"> <li>• The EVSE determines that the insulation resistance of side B is <math>\geq 100</math> k<math>\Omega</math>. See CC.4.1.1.</li> </ul>

Timestamp	Description
t706	<ul style="list-style-type: none"> <li>• After completing the cable-check phase, the EVSE shall send message CableCheckRes &lt;4b&gt; with parameters "EVSEIsolationStatus" according to CC.4.1.4, "EVSEProcessing" = 'Finished', and                             <ul style="list-style-type: none"> <li>– "EVSEStatusCode" = "Ready", if the insulation status is 'Valid' and there are no errors, or</li> <li>– "ResponseCode" = 'FAILED', if the EVSE detects an error, in order to trigger an EVSE initiated error shutdown.</li> </ul> </li> <li>• If the EVSE detects an error, the EVSE shall trigger an EVSE initiated error shutdown by sending parameters "EVSEIsolationStatus" according to CC.4.1.4 and "ResponseCode" = 'FAILED' in message CableCheckRes &lt;4b&gt;.</li> </ul>
t706 ► t707	<ul style="list-style-type: none"> <li>• The EVSE may keep a present voltage at side B.</li> </ul>
t707	<ul style="list-style-type: none"> <li>• The EV shall send message PreChargeReq &lt;5a&gt;, with parameter "EVTargetVoltage" depending on the present voltage of the battery system, to start the pre-charge stage. See CC.5.1.</li> <li>• It is recommended that the EV sends the PreChargeReq &lt;5a&gt; messages with parameter "EVTargetVoltage" = '0'.</li> </ul>
t707 ► t709	<ul style="list-style-type: none"> <li>• The EV and EVSE shall perform pre-charge according to CC.5.1.</li> <li>• The EVSE shall control the present voltage at side B according to the target voltage of the EV in the PreChargeReq &lt;5a&gt; messages, and send the corresponding PreChargeRes &lt;5b&gt; messages.</li> </ul>
t708	<ul style="list-style-type: none"> <li>• The present voltage at side B reaches the target voltage of the EV between the tolerances given in 101.1.2.</li> </ul>
t708 ► t709	<ul style="list-style-type: none"> <li>• The EV may adapt the target voltage of the EV with cyclic PreChargeReq/Res messages to compensate for voltage deviation.</li> </ul>
t709	<ul style="list-style-type: none"> <li>• If the EV decides to close the EV disconnection device, the EV shall close the EV disconnection device only after verifying that the absolute difference between the present voltage at side B between DC+ and DC– and the present voltage of the battery system is &lt; 20 V DC. See CC.5.1.</li> </ul> <p>The EV should be protected against the case that the polarity of side B is reversed.</p> <ul style="list-style-type: none"> <li>• If the EV sent a target voltage of the EV "EVTargetVoltage" = '0' in the PreChargeReq &lt;5a&gt; messages, the EV shall not close the EV disconnection device.</li> </ul>
t710	<ul style="list-style-type: none"> <li>• The EV sends PowerDeliveryReq &lt;8a&gt; with parameter "ChargeProgress" = 'Stop' to initiate the pause.</li> </ul> <p>NOTE 6 The pause can be initiated by the EV or by the EVSE with the NotificationMaxDelay value in ChargeParameterDiscovery.</p>
t711	<ul style="list-style-type: none"> <li>• After receiving the PowerDeliveryReq &lt;8a&gt; message, the EVSE shall disable the EVSE IMD, disable side B and open the EVSE disconnection device, if any.</li> </ul>
t711 ► t718	<ul style="list-style-type: none"> <li>• The disabled side B of the EVSE shall have equivalent electrical properties/behaviour (for example, impedance, discharge rate, etc.) as the circuit described in CC.2.4.</li> </ul>
t712	<ul style="list-style-type: none"> <li>• After disabling the pre-charge circuit, if any, and disabling the EVSE IMD, the EVSE shall respond with message PowerDeliveryRes &lt;8b&gt;.</li> <li>• The EVSE shall respond with message PowerDeliveryRes &lt;8b&gt; after it has                             <ul style="list-style-type: none"> <li>– disabled its pre-charge circuit,</li> <li>– disabled side B and opened the EVSE disconnection device, if any, and</li> <li>– disabled the EVSE IMD.</li> </ul> </li> </ul>
t713	<ul style="list-style-type: none"> <li>• The EV may enable the EV IMD, if any.</li> </ul>
t713 ► t714	<ul style="list-style-type: none"> <li>• The EV shall maintain CP state C after receiving the PowerDeliveryRes &lt;8b&gt; message.</li> <li>• The EV may perform welding detection of the EV disconnection device without sending WeldingDetectionReq &lt;9a&gt; messages.</li> </ul> <p>NOTE 7 If the EV decides not to perform welding detection, it proceeds with t711.</p>
t714	<ul style="list-style-type: none"> <li>• The EV completes welding detection, if performed.</li> <li>• The EV shall open the EV disconnection device.</li> </ul> <p>NOTE 8 The opening of the EV disconnection device starts the reduction of the present voltage at side B by passive discharge because the EVSE has not yet received message SessionStopReq &lt;10a&gt;.</p>

Timestamp	Description
t715	<ul style="list-style-type: none"> <li>The EV shall change to CP state B to indicate that the EV disconnection device is open.</li> <li>The EV shall keep the vehicle connector locked.</li> </ul>
t716	<ul style="list-style-type: none"> <li>The EV shall send the SessionStopReq &lt;10a&gt; message with parameter "ChargingSession" = 'Pause'.</li> </ul>
t716 ► t717	<ul style="list-style-type: none"> <li>The EVSE shall, in 1 s or less, reduce the present voltage at side B to <math>\leq 60</math> V DC between <ul style="list-style-type: none"> <li>– DC+ and DC–,</li> <li>– DC+ and PE, and</li> <li>– DC– and PE.</li> </ul> </li> </ul> <p>NOTE 9 The EVSE can actively discharge side B because the EV has opened the EV disconnection device</p>
t717	<ul style="list-style-type: none"> <li>The EVSE shall send message SessionStopRes &lt;10b&gt; and pause the data link.</li> <li>The EVSE shall turn off its CP oscillator according to IEC 61851-24.</li> </ul>
t717 ► t718	<ul style="list-style-type: none"> <li>Duration of the communication session pause.</li> <li>If the EV or EVSE want to stop the communication session, the EV or EVSE, respectively, shall perform a restart to end the pause (see CC.5.2), followed by a normal startup (see t1 ► t2 in Table CC.8) and then a normal shutdown (see CC.3.3).</li> <li>If the EV or EVSE want to resume the communication session, the EV or EVSE, respectively, shall end the pause by performing a restart (see CC.5.2) followed by a normal startup (see CC.3.2).</li> <li>The EV may unlock the vehicle connector. It is recommended to keep the vehicle connector locked.</li> <li>If the vehicle connector is un-mated, the EVSE shall terminate the data link according to IEC 61851-24.</li> </ul>
t718	<ul style="list-style-type: none"> <li>The EVSE shall turn on its CP oscillator according to IEC 61851-24, to indicate to the EV that power is now available.</li> <li>The EVSE shall continue to t1 in the normal startup sequence CC.3.2.</li> </ul>

### CC.3.6 Renegotiation initiated by EV or EV supply equipment using ISO 15118-2:2014

In case the EV or EV supply equipment want to change the negotiated parameters communicated in the initialization phase with ChargeParameterDiscoveryReq/Res (for example, rated boost current of the EV supply equipment at side B, rated continuous power of the EV supply equipment at side B) during energy transfer, the EV or EV supply equipment can trigger a renegotiation. This sequence is only possible if using ISO 15118-2:2014 as a digital communication standard.

The sequence and description of renegotiation initiated by the EV supply equipment are shown in Figure CC.13 and Table CC.17.

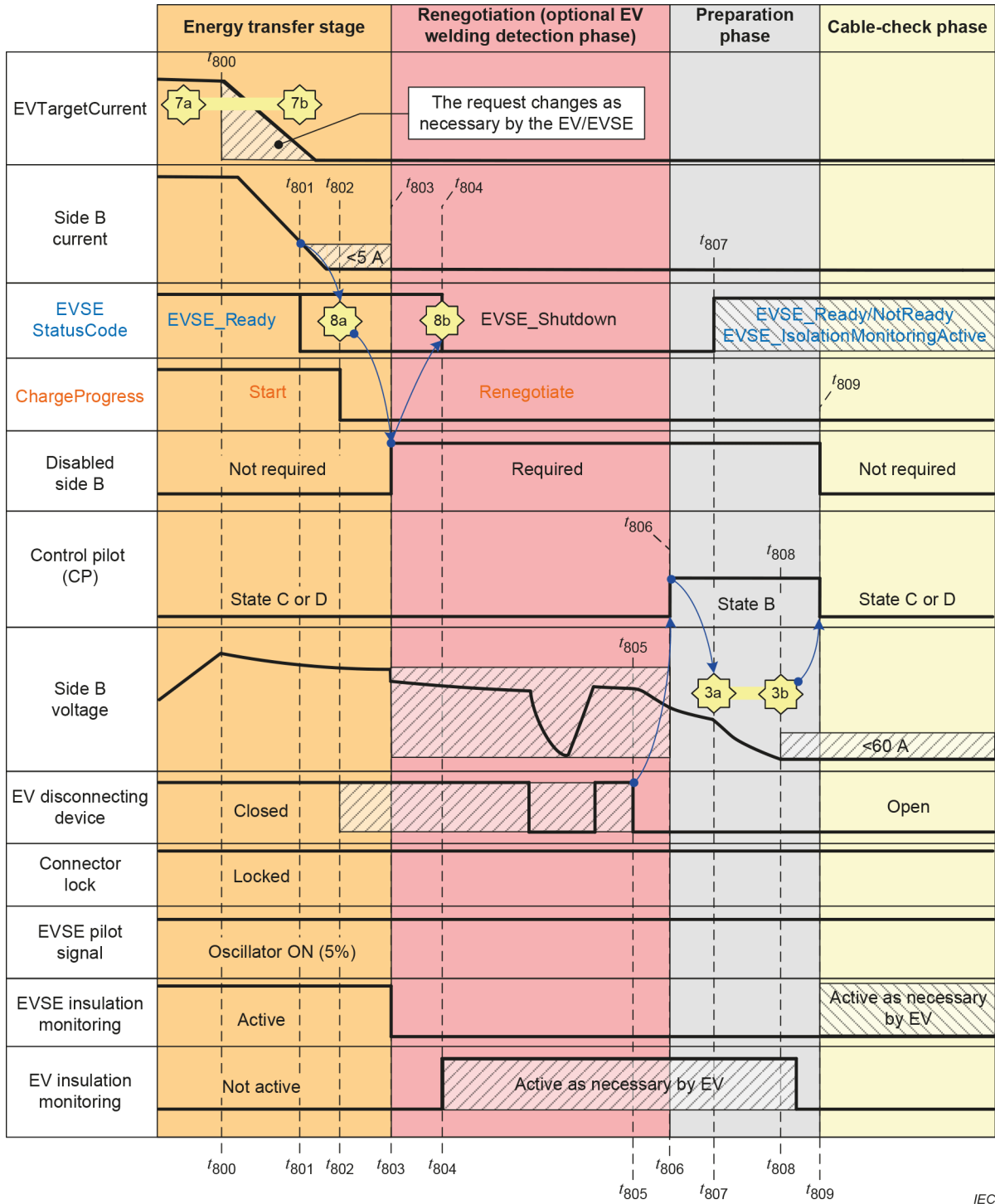

**Figure CC.13 – Sequence diagram for renegotiation initiated by EV or EV supply equipment using ISO 15118-2:2014**

**Table CC.17 – Sequence description for renegotiation initiated by EV or EV supply equipment using ISO 15118-2:2014**

Timestamp	Description
▶ t800	<ul style="list-style-type: none"> <li>Cyclic CurrentDemandReq/Res messages between the EV (CurrentDemandReq &lt;7a&gt;) and EVSE (CurrentDemandRes &lt;7b&gt;).</li> </ul>
t800	<ul style="list-style-type: none"> <li>If the EV wants to start a renegotiation process of a communication session to change the negotiated parameters, the EV shall request a reduction of the present current at side B to 0 A in the next CurrentDemandReq &lt;7a&gt; messages.</li> </ul>
t800 ▶ t801	<ul style="list-style-type: none"> <li>If the EVSE wants to start a renegotiation process of a communication session to change the energy transfer parameters, the EVSE shall <ul style="list-style-type: none"> <li>ramp down the present current at side B to &lt; 5 A DC, and</li> <li>adjust parameter "EVSEMaximumCurrentLimit" in the next CurrentDemandRes &lt;7b&gt; messages according to the present current at side B.</li> </ul> </li> </ul> <p>See 101.1.3, CC.5.5.4 and CC.5.5.6.</p> <p>NOTE 1 EVs based on IEC 61851-23:2014 might not support renegotiation and directly go to t101 without reducing the target current of the EV. The EVSE will interpret this as an EV initiated error shutdown. See Table CC.10.</p> <p>NOTE 2 The EVSE can limit the present current at side B ramp down to –20 A/s to avoid sudden load variations at side A (for example, supply network connection).</p>
t801	<ul style="list-style-type: none"> <li>If the EVSE wants to trigger a renegotiation process, the EVSE shall send parameter "EVSEStatusCode"='EVSE_Shutdown' and "EVSENotification" = 'ReNegotiation' in the next CurrentDemandRes &lt;7b&gt; message when the present current at side B is &lt; 5 A DC.</li> </ul>
t802	<ul style="list-style-type: none"> <li>To trigger the renegotiation, the EV requests the EVSE to disable side B by sending message PowerDeliveryReq &lt;8a&gt; with parameter "ChargeProgress" = 'Renegotiate', after the current is &lt; 5 A DC.</li> </ul>
t802 ▶ t807	<ul style="list-style-type: none"> <li>The EV may open the EV disconnection device after the present current at side B is &lt; 5 A and after the message PowerDeliveryReq &lt;8a&gt; has been sent.</li> </ul>
t803	<ul style="list-style-type: none"> <li>The EVSE shall stop the overvoltage protection according to 6.3.1.106, and then, the EVSE shall disable side B, and open the EVSE disconnection device, if any.</li> </ul> <p>NOTE 3 If the EVSE disables side B while the present current at side B is &gt; 0 A DC, the present voltage at side B drops to the present voltage of the battery system because the EV disconnection device is still closed.</p> <ul style="list-style-type: none"> <li>The EVSE shall disable the EVSE IMD.</li> </ul>
t803 ▶ t809	<ul style="list-style-type: none"> <li>The disabled side B of the EVSE shall have equivalent electrical properties/behaviour (for example, impedance, discharge rate, etc.) as the circuit described in CC.2.4.</li> </ul>
t804	<ul style="list-style-type: none"> <li>The EVSE shall communicate that the present current at side B is &lt; 5 A DC and has disabled side B by sending parameter "EVSEStatusCode"='EVSE_Shutdown' in message PowerDeliveryRes &lt;8b&gt;.</li> <li>The EVSE shall not turn off its CP oscillator during renegotiation.</li> <li>The EV may enable the EVSE IMD, if any.</li> </ul>
t804 ▶ t805	<ul style="list-style-type: none"> <li>The EV shall maintain CP state C after receiving message PowerDeliveryRes &lt;8b&gt;.</li> <li>The EV may perform welding detection of the EV disconnection device without sending WeldingDetectionReq &lt;9a&gt; messages.</li> </ul> <p>NOTE 4 If the EV decides not to perform welding detection, it proceeds with t805.</p>
t805	<ul style="list-style-type: none"> <li>The EV completes welding detection, if performed.</li> <li>The EV shall open the EV disconnection device.</li> </ul> <p>NOTE 5 The opening of the EV disconnection device starts the reduction of the present voltage at side B by passive discharge because the EVSE has not yet received message SessionStopReq &lt;10a&gt;.</p>
t806	<ul style="list-style-type: none"> <li>The EV shall change to CP state B to indicate that the EV disconnection device is open.</li> <li>The EV shall keep the vehicle connector locked.</li> </ul>

Timestamp	Description
t806 ► t808	<ul style="list-style-type: none"> <li>The EVSE shall, in 1 s or less, reduce the present voltage at side B to <math>\leq 60</math> V DC between                             <ul style="list-style-type: none"> <li>– DC+ and DC–,</li> <li>– DC+ and PE, and</li> <li>– DC– and PE.</li> </ul> </li> </ul> <p>NOTE 6 The EVSE can actively discharge side B because the EV has opened the EV disconnection device.</p>
t807	<ul style="list-style-type: none"> <li>The EV shall send parameters "EVMaximumVoltageLimit" and "EVMaximumCurrentLimit" (amongst other parameters) to limit the present current and voltage at side B with the first ChargeParameterDiscoveryReq &lt;3a&gt; message.</li> </ul>
t807 ► t808	<ul style="list-style-type: none"> <li>The EVSE shall check if the present voltage at side B between DC+ and DC– is <math>&lt; 60</math> V DC and shall send message ChargeParameterDiscovery &lt;3b&gt; with parameter "EVSEProcessing" = 'Ongoing' if the present voltage at side B is <math>&gt; 60</math> V DC.</li> <li>The EVSE shall perform a compatibility check. See CC.5.6.</li> <li>The EVSE shall send parameters "EVSEMaximumVoltageLimit", "EVSEMinimumVoltageLimit", "EVSEMaximumCurrentLimit" and "EVSEMinimumCurrentLimit" (amongst other parameters) in message ChargeParameterDiscoveryRes &lt;3b&gt; considering the compatibility check. See CC.5.6 on how to calculate these values.</li> <li>The EVSE shall send parameter "EVSEStatusCode" = 'EVSE_IsolationMonitoringActive' in the "ChargeParameterDiscoveryRes &lt;3b&gt;" messages, unless the EVSE wants to perform a shutdown. The EV is recommended to continue the communication session if the EVSE sends ChargeParameterDiscoveryRes &lt;3b&gt; messages with parameter "EVSE_StatusCode" = 'EVSE_Ready' or 'EVSE_NotReady'.</li> </ul> <p>NOTE 7 EVSEs based on IEC 61851-23:2014 can send parameter "EVSE_StatusCode" = "EVSE_Ready", "EVSE_NotReady", or "EVSE_IsolationMonitoringActive" in ChargeParameterDiscoveryRes &lt;3b&gt; messages.</p> <ul style="list-style-type: none"> <li>If the EVSE replies with parameters "ResponseCode" = 'OK' and "EVSEProcessing" = 'Ongoing' in message ChargeParameterDiscoveryRes &lt;3b&gt;, the EV and EVSE may update the parameters sent in the next ChargeParameterDiscoveryReq/Res messages.</li> </ul> <p>NOTE 7 The EVSE can use "EVSEProcessing" = 'Ongoing' for other reasons. Example: load management, etc.</p> <ul style="list-style-type: none"> <li>ISO 15118-2:2014 does not specify the possibility to update the parameters in subsequent ChargeParameterDiscoveryReq/Res messages; however, it is recommended for the EVSE not to perform a shutdown if the EV changes the parameters.</li> <li>To improve interoperability, the EVSE shall tolerate the EV changing CP state to C/D during cyclic ChargeParameterDiscoveryReq/Res messages. If the EV changes back to CP state B, the EVSE shall trigger an EVSE initiated emergency shutdown. See CC.3.4.3.</li> </ul> <p>Requirement [V2G2-912] in ISO 15118-2:2014 and a similar requirement in outdated versions of SAE J1772 do not specify that the EV shall receive a ChargeParameterDiscoveryRe &lt;3b&gt; with parameter "EVSEProcessing" = "Finished" before changing the CP state from state B to state C/D, leading to this unwanted behaviour.</p>
t808	<ul style="list-style-type: none"> <li>If the present voltage at side B is <math>&lt; 60</math> V DC, the EVSE shall send the EV the result of the compatibility check in message ChargeParameterDiscoveryRes &lt;3b&gt; using parameters "EVSEStatusCode" = 'EVSE_IsolationMonitoringActive', "EVSEProcessing" = 'Finished', and                             <ul style="list-style-type: none"> <li>– "ResponseCode" = 'OK' if the compatibility check was completed successfully, or</li> <li>– "ResponseCode" = 'FAILED_WrongChargeParameter' if the compatibility check was completed and failed, triggering an EVSE initiated error shutdown.</li> </ul> </li> </ul> <p>NOTE 8 A ChargeParameterDiscoveryRes &lt;3b&gt; message with "ResponseCode" = 'FAILED_WrongChargeParameter' and parameter "EVSEProcessing" = 'Ongoing', will trigger an EVSE initiated error shutdown. See error handling specifications for the digital communication standards in IEC 61851-24.</p> <p>NOTE 9 EVSEs based on IEC 61851-23:2014 can send parameter "EVSE_StatusCode" = "EVSE_Ready", "EVSE_NotReady", or "EVSE_IsolationMonitoringActive" in ChargeParameterDiscoveryRes &lt;3b&gt; messages. The EV is recommended to continue the communication session if the EVSE sends ChargeParameterDiscoveryRes &lt;3b&gt; messages with parameter "EVSE_StatusCode" = 'EVSE_Ready' or 'EVSE_NotReady'.</p> <ul style="list-style-type: none"> <li>The negotiated maximum values sent by the EVSE in the last ChargeParameterDiscoveryRes &lt;3b&gt; shall be more than or equal to the applicable values in the CurrentDemandRes &lt;7b&gt; messages during energy transfer. See CC.5.6.</li> </ul>

Timestamp	Description
t808 ► t809	<ul style="list-style-type: none"> <li>• If the EV and EVSE are not compatible, the EV shall perform an EV initiated error shutdown. See CC.3.4.2.</li> <li>• The EV shall lock the vehicle connector in the vehicle inlet before changing the CP to state C or D, if not already locked.</li> <li>• If the EV failed to lock the vehicle connector, the EV shall trigger an EV initiated error shutdown with parameter "EVErrorCode" = 'FAILED_ChargerConnectorLockFault' in the next communicated message.</li> <li>• The EV shall disable the EV IMD, if any.</li> </ul>
t809	<ul style="list-style-type: none"> <li>• The communication session continues as in t4 of the normal startup sequence CC.3.2.</li> <li>• The limitations of the disabled side B of the EVSE are not required.</li> </ul>

## CC.4 Safety related functions

### CC.4.1 Safety measures for side B

#### CC.4.1.1 General

The side B of the EV supply equipment shall implement the provisions for basic protection, fault protection and special protection as specified in 8.105.1.

#### CC.4.1.2 Cable-check phase

Requirements for protection against overvoltage at the vehicle connector according to 6.3.1.106 do not apply during the cable-check phase.

During the cable-check phase, the EV supply equipment shall perform the following checks.

- Perform and finish the functional check of the IMD under a controlled voltage at side B according to CC.4.1.3.
- Perform the insulation resistance check under a controlled voltage at side B according to CC.4.1.4.
- Perform the short-circuit check before energy transfer according to 6.3.1.109.
- Optional: perform a welding check of the EV supply equipment disconnection device during the cable-check phase. If the EV supply equipment performs a welding detection, then the EV supply equipment shall still comply with the requirements of 6.3.1.112.

If the results of all the checks during the cable-check phase are "Passed" or "Valid", the EV supply equipment shall send message CableCheckRes <4b> with parameters "EVSEIsolationStatus" = 'Valid' and "ResponseCode" = 'OK', and "EVSEProcessing" = 'Finished' in the last "CableCheckReq" <4b> message.

During the cable-check phase, the EV supply equipment shall limit the present current at side B to a maximum of 20 A.

In order to fulfil the timing requirements of the digital communication according to IEC 61851-24, the EV supply equipment shall be able complete the cable-check phase (including measuring the insulation state according to CC.4.1.4) within V2G\_SECC\_CableCheck\_Performance\_Time (= 38 s according to DIN SPEC 70121:2014 and ISO 15118-2:2014).

In the cable-check phase, during the functional check of the IMD and the insulation resistance check, the EV supply equipment shall apply a controlled present voltage at side B according to the rated maximum voltage values communicated in the last set of ChargeParameterDiscoveryReq/Res messages. See Formula (CC.1).

$$V_{EVSE\_CableCheck} = \min (V_{EV\_MAX\_CPD} + 50 \text{ V}, V_{EVSE\_MAX\_CPD}, 500 \text{ V}),$$

if  $V_{EV\_MAX\_CPD} \leq 500 \text{ V}$

(CC.1)

$$V_{EVSE\_CableCheck} = \min (1,1 \times V_{EV\_MAX\_CPD}, V_{EVSE\_MAX\_CPD}),$$

if  $V_{EV\_MAX\_CPD} > 500 \text{ V}$

where

$V_{EV\_MAX\_CPD}$  is the rated maximum voltage of the EV communicated in the last ChargeParameterDiscoveryReq, expressed in volts;

$V_{EVSE\_MAX\_CPD}$  is the rated maximum voltage of the EV supply equipment at side B communicated in the last ChargeParameterDiscoveryRes, expressed in volts;

$V_{EVSE\_CableCheck}$  is the present voltage at side B during the functional check of the IMD and the insulation resistance check, expressed in volts.

During the functional check of the IMD and the insulation resistance check,

- the voltage deviation of the  $V_{EVSE\_CableCheck}$  shall be between  $\pm 5 \%$  of the  $V_{EV\_MAX\_CPD}$ , or  $\pm 2 \%$  of the  $V_{EVSE\_MAX\_CPD}$ , whichever deviation is less,
- the impedance between DC+ and DC– should be less than 1 k $\Omega$  to avoid additional measurement errors of the IMD, and
- the EV shall be able to withstand  $V_{EVSE\_CableCheck}$  in both normal and reverse polarity.

The EV supply equipment shall only send the last "CableCheckRes" <4b> message with parameter "EVSEProcessing" = 'Finished' after the present voltage at side B is < 60 V DC.

#### CC.4.1.3 Functional check of the insulation monitoring device

The functional check of the IMD shall detect if the IMD is connected to the side B live parts (DC+/DC–) and the protective conductor, and that the IMD is capable of determining the insulation resistances between DC+ and the protective conductor, as well as between DC– and the protective conductor. Failure of redundant connections needs to be verified by interrupting all the IMD connections.

The functional check of the IMD shall not negatively influence the IMD and the side B circuit. The side B circuit to be monitored shall not be directly earthed when the functional check is activated.

NOTE 1 During the functional check of the IMD, the requirements of 8.105.1 are applicable.

The result of the functional check can be as follows.

- a) Unknown: Functional check of the IMD has not been executed yet. With this result, the EV supply equipment shall not be allowed to continue to insulation resistance check according to CC.4.1.4.
- b) Passed: After the functional check of the IMD has been passed, the EV supply equipment is allowed to continue to the insulation resistance check according to CC.4.1.4.

- c) Failed: The functional check of the IMD has failed. With this result, the EV supply equipment shall not be allowed to continue to insulation resistance check according to CC.4.1.4. The EV supply equipment shall trigger an error shutdown, with parameter "EVSEIsolationStatus" = 'Fault' and "ResponseCode" = 'FAILED', and "EVSEProcessing" = 'Finished' in the last "CableCheckReq" <4b> message.

NOTE 2 The purpose of this functional check of the IMD is to check whether the IMD is capable of fulfilling its monitoring function on side B of the EV supply equipment and not to check if the insulation resistance of side B is less than a certain threshold.

NOTE 3 During the activation of the functional check of the IMD, the response time of the IMD can be extended as long the extension of a response time of measurement does not occur during the energy transfer stage.

*Compliance is checked by CC.7.6.21 for the IMD measurement connections to the side B live parts (DC+/DC-) and the protective conductor.*

#### **CC.4.1.4 Insulation resistance check**

The insulation resistance check shall be performed only after a "Passed" result of the functional check of the IMD according to CC.4.1.3.

During the insulation resistance check, the present voltage at side B shall be as defined in CC.4.1.2 for 1 s or more.

The insulation states of parameter "EVSEIsolationStatus" in message "CableCheckRes" <4b> can be as follows.

- a) Invalid: The IMD has not finished the insulation resistance check. The EV shall trigger an error shutdown if the EV supply equipment maintains parameter "EVSEIsolationStatus" = 'Invalid' in message "CableCheckRes" <4b> at the end of the cable-check phase (see CC.4.1.2).
- b) Valid: The measured insulation resistance between side B live parts (DC+/DC-) and the protective conductor is  $\geq 100 \text{ k}\Omega$  (without negative tolerance). The EV supply equipment shall continue with the cable-check phase if the IMD remains in "Valid" state and shall indicate the insulation state "Valid" to the EV by digital communication according to IEC 61851-24.
- c) Fault: The measured insulation resistance between side B live parts (DC+/DC-) and the protective conductor is  $< 100 \text{ k}\Omega$  (without negative tolerance). The EV supply equipment shall trigger an error shutdown before or at the end of the cable-check phase if the IMD detects a "Fault" state and shall indicate the insulation state "Fault" to the EV by digital communication according to IEC 61851-24.

*Compliance is checked by CC.7.6.13.*

#### **CC.4.1.5 Error shutdown upon first insulation fault**

The EV supply equipment shall perform an error shutdown (see CC.3.4.2) after the occurrence of a first insulation fault. An IMD according to IEC 61557-8 or equivalent shall be used to perform insulation monitoring between DC+ and the protective conductor, as well as between DC- and the protective conductor during the energy transfer stage. Insulation monitoring can be performed by

- determining the total insulation resistance of side B live parts (DC+ and DC-) and protective conductor, or
- separately determining the insulation resistance between side B live parts (DC+ and DC-) and protective conductor.

The present insulation state (Valid, Fault) of side B shall periodically be sent to the EV by means of digital communication, see IEC 61851-24.

If the insulation resistance cannot be determined, for example, due to disturbances of the measurement or if the IMD is not supplied, the EV supply equipment shall trigger and perform an error shutdown.

NOTE In some cases, the insulation resistance cannot be determined because of an internal failure or external factors, for example, if the capacitance in the EV is more than the expected value as defined in ISO 17409:2020.

The EV supply equipment shall react to both conditions 1 and 2 independently according to Table CC.18.

**Table CC.18 – Insulation states and EV supply equipment reaction based on the insulation resistance**

Condition 1 (asymmetric insulation resistance) <sup>a</sup>	Condition 2 (symmetric insulation resistance) <sup>a</sup>	Insulation state	EV supply equipment reaction
Case 3 and Case 4	Case 1	Valid	Allow energy transfer
Case 5 and Case 6	Case 2	Fault	Error shutdown

<sup>a</sup> See application of the test resistors in the test methods in CC.7.6.13 and CC.7.6.14.

Resistor values used in the test cases:

Symmetric insulation resistance test

Case 1: Two test resistors  $R = 300_0^{+2\%} \text{ k}\Omega$

Case 2: Two test resistors  $R = 100_0^{+2\%} \text{ k}\Omega$

Asymmetric insulation resistance test:

Case 3: Test resistor  $R = 150_0^{+2\%} \text{ k}\Omega$

Case 4: Test resistor  $R = 150_0^{+2\%} \text{ k}\Omega$

Case 5: Test resistor  $R = 100_0^{+2\%} \text{ k}\Omega$

Case 6: Test resistor  $R = 100_0^{+2\%} \text{ k}\Omega$

*Compliance is checked by CC.7.6.13 and CC.7.6.14.*

**CC.4.1.6 Insulation monitoring after the cable-check phase**

During the pre-charge phase and the energy transfer stage, the insulation resistance of side B shall be continuously monitored. The insulation states are shown in Table CC.18.

In case disturbances prevent a correct insulation resistance measurement by the IMD, the EV supply equipment shall trigger an error shutdown in 30 s or less after the last valid insulation resistance measurement.

In any other case, the EV supply equipment shall trigger an error shutdown in 10 s or less after the occurrence of a fault according to Table CC.18.

NOTE 1 The EV supply equipment can issue an optical and/or acoustical signal to the user.

NOTE 2 ISO 17409:2020, 9.4, contains the requirement for the EV insulation resistance monitoring system to avoid interference with the IMD of the EV supply equipment, from time t3 in Figure CC.5.

*Compliance is checked by CC.7.6.14.*

#### **CC.4.2 Vehicle coupler latching function**

For all types of vehicle couplers according to Table CC.1, the vehicle inlet shall provide a latching function to mitigate unintentional un-mating of the vehicle connector from the vehicle inlet during energy transfer.

The requirement for the latching function is stated in ISO 17409.

#### **CC.4.3 Loss of electrical continuity of the control pilot conductor**

When an unintended transition from CP state C/D to state B/A, any other or an unknown state occurs, the EV supply equipment shall trigger an emergency shutdown in 10 ms or less.

*Compliance is checked by CC.7.6.2 and CC.7.6.15.*

When an unintended transition from CP state C/D to state B/A, any other or an unknown state occurs, the EV shall trigger an emergency shutdown in 50 ms or less.

#### **CC.4.4 Loss of electrical continuity of the proximity detection conductor**

For vehicle connectors of configuration EE, when the voltage measured at the proximity detection contact is  $< 0,8 \text{ V DC}$  or  $> 3,6 \text{ V DC}$ , the EV supply equipment shall trigger an emergency shutdown, in accordance with 6.3.1.113.4, in 10 ms or less. The proximity pilot shall be implemented according to Figure CC.1.

*Compliance is checked by CC.7.6.6.*

#### **CC.4.5 Voltage check at initialization**

The voltage check at initialization shall be as specified in the sequences in Clause CC.3 and 6.3.1.106.

#### **CC.4.6 Minimum cross-sectional area of the protective conductor**

The minimum cross-sectional area of the protective conductor shall be  $6 \text{ mm}^2$ .

*Compliance is checked by inspection.*

#### **CC.4.7 Loss of electrical continuity of the protective conductor**

The EV supply equipment shall trigger an emergency shutdown in 150 ms or less if a loss of electrical continuity of the protective conductor occurs anywhere from the inside of the EV supply equipment up to the point A (see Figure CC.1 and Figure CC.2).

*Compliance is checked by CC.7.6.3.*

The EV shall monitor the electrical continuity of the protective conductor from point A (see Figure CC.1 and Figure CC.2) to the EV by doing the following.

- The EV shall check the PP circuit before each initiating a communication session for correct values specified by the EV manufacturer, this includes the continuity of the protective conductor from point A up to the EV.
- The EV shall either open switch  $S_{\sqrt{3}}$  from Figure CC.2 when it changes the CP state from B to C or the EV shall check the PP circuit during energy transfer and, in case of losing of electrical continuity of the protective conductor, the EV shall trigger an emergency shutdown in 150 ms or less.

### CC.5 Additional functions

#### CC.5.1 Pre-charge

During the pre-charge phase, the EV supply equipment shall operate in CVM to follow the target voltage of the EV according to 101.1.2.2 and 101.1.6. The EV supply equipment shall

- be able to pre-charge the circuit defined in Figure CC.14 with the values according to Table CC.19 for its entire operating range in 3 s or less, and
- subsequently follow a change in the target voltage of the EV of a maximum of  $\pm 50$  V DC in 1 s or less.

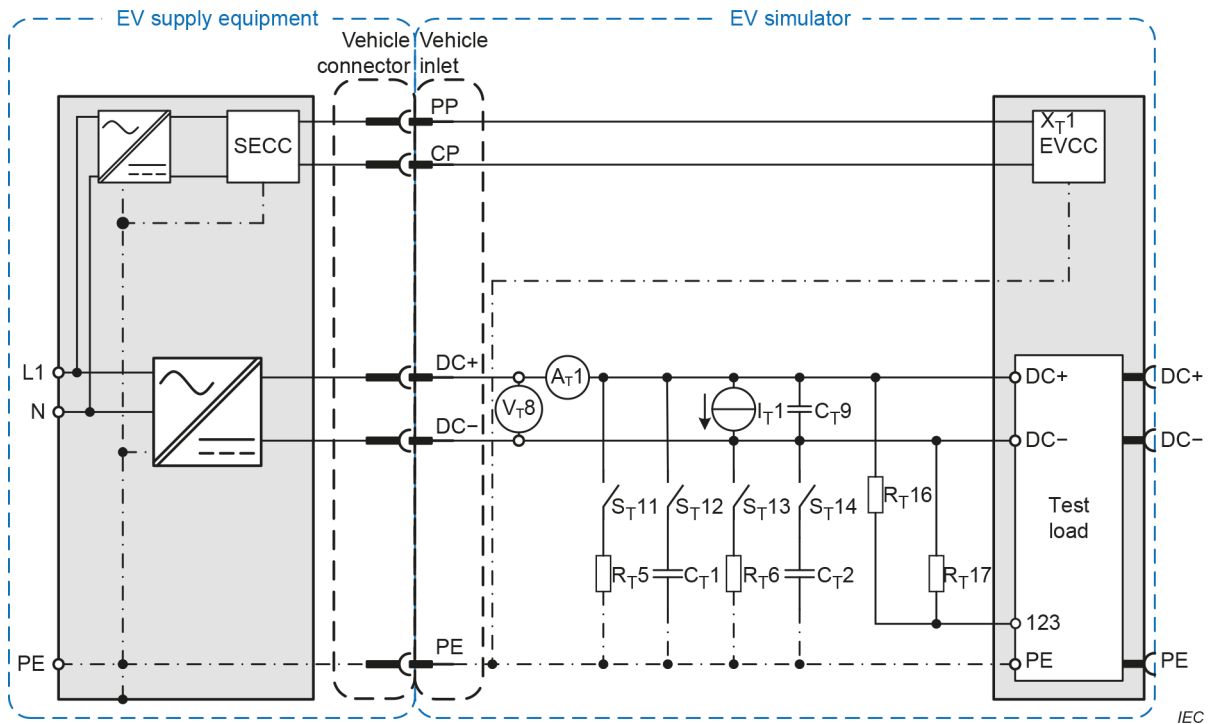

**Key**

- $I_T1$  EV current load
- $C_{T1}, C_{T2}$  maximum Y-capacitance on the vehicle inlet
- $C_{T9}$  maximum X-capacitance on the vehicle inlet
- $R_{T5}, R_{T6}$  minimum insulation resistance (due to an error) on the vehicle inlet
- $R_{T16}, R_{T17}$  minimum resistance of the EV simulator measurement circuit on vehicle inlet
- $A_{T1}$  ammeter in the EV simulator
- $V_{T8}$  voltmeter in the EV simulator
- Test load test load according to 102.2.4 unless otherwise specified (see Figure 132)

NOTE Diagram based on the test setup for system C with additional components  $I_{T1}$ ,  $C_{T9}$ ,  $R_{T16}$  and  $R_{T17}$ . See Figure 131.

**Figure CC.14 – Worst case equivalent circuit during pre-charge**

**Table CC.19 – Values to design the EV supply equipment during pre-charge based on Figure CC.14**

Symbol	Value
$I_{T1}$	12 mA $\pm$ 2 mA
$C_{T1}, C_{T2}$	2 $\mu$ F
$C_{T9}$	10 nF
$R_{T5}, R_{T6}$	100 k $\Omega$
$R_{T16}, R_{T17}$	500 k $\Omega$
$S_{T17}$	Closed
$S_{T18}$	Open

During pre-charge, the EV shall limit its current draw between DC+ and DC– to 10 mA.

According to ISO 17409, the voltage difference between both sides of the EV disconnection device shall be < 20 V DC before the EV closes the EV disconnection device.

The EV shall not close the EV disconnection device if the polarity of side B is reversed.

The EV shall measure the present voltage at side B at the vehicle inlet and may use the measured voltage for adjusting the subsequent target voltage of the EV during pre-charge. It is recommended for the EV not to modify the target voltage of the EV in 3 s or less after the first pre-charge request message.

The EV shall not solely use the measured voltage at side B communicated by the EV supply equipment to check if the absolute difference between the present voltage at side B and the present voltage of the battery system is  $\leq 20$  V.

The EV supply equipment may trigger an error shutdown if the PowerDeliveryReq <6a> message is not received by the EV supply equipment in 20 s or less after receiving the first PreChargeReq <5a> message.

NOTE 1 This is to limit the heating of the pre-charge circuit in the EV supply equipment.

During the entire pre-charge phase (from  $t_7$  to  $t_{11}$ ), the EV supply equipment shall operate in CVM to follow the target voltage of the EV and shall limit the present current at side B to a maximum of  $\pm 2$  A DC. The target current of the EV shall be ignored.

From the beginning of the pre-charge phase ( $t_7$ ) until the EV supply equipment receives message PowerDeliveryReq <6a>, the EV supply equipment shall limit the present current at side B to <  $\pm 20$  A peak, including the inrush current and a continuous current, if any.

From the reception of message PowerDeliveryReq <6a> until the end of the pre-charge phase ( $t_{10}$ ), the EV supply equipment shall

- limit the present current at side B to <  $\pm 125$  A peak, including the transient current and a continuous current, if any, and
- limit the integral of the present current at side B  $> 2$  A over time ( $I > 2$  A  $\times t$ ) to  $\leq 3$  As.

NOTE 2 The inrush current is the transient current due to the energization of cables and capacitors when the EV closes the EV disconnection device. It is not a continuous current.

NOTE 3 The EV might close several EV disconnection devices in individual steps between  $t_7$  and sending message PowerDeliveryReq <6a>.

*Compliance is checked by CC.7.6.8 by testing the EV supply equipment configuration with the lowest inductance (for example, shortest side B cable assembly), and CC.7.6.11.*

## **CC.5.2 Sleep mode and communication session restart methods**

### **CC.5.2.1 General**

Sleep mode is an operating mode of the EV supply equipment or EV designed for reduced energy consumption when a communication session is not occurring. In this case, the EVCC or SECC are permitted to not communicate via digital communication.

The EV can request a pause of the communication session, after which both EV and EV supply equipment can enter sleep mode. Additionally, the EV supply equipment can indicate the EV to request a communication session pause due to the behaviour of the supply network. See CC.3.5.

NOTE The behaviour of the supply network can be influenced by, for example, smart charging profiles, supply availability and/or DSO.

To restart digital communication, the EV or EV supply equipment can perform a restart method as specified in CC.5.2.3 and CC.5.2.4.

The restart methods can also be used to restart digital communication after an error condition, for example, loss of digital communication.

### **CC.5.2.2 Sleep mode on the EV supply equipment**

The EV supply equipment may support a sleep mode according to ISO 15118-3:2015 to minimize power consumption as described as an optional function in 6.3.2.101.

The EV supply equipment may enter a sleep mode, if

- there is no digital communication (application layer messages) for more than 2 consecutive min, or
- the EV requests a communication session pause according to ISO 15118-2:2014, 8.4.2 (see CC.3.3 and CC.3.5).

During sleep mode, the CP oscillator of the EV supply equipment shall be off, while the CP voltage source  $X_S1$  is enabled (CP state x1). See Clause CC.2.

See CC.5.2.4 on how the EV can perform a wake-up of the EV supply equipment or restart a communication session.

### **CC.5.2.3 Restart by the EV supply equipment**

#### **CC.5.2.3.1 General**

The EV supply equipment shall perform the restart methods as described in Figure CC.15 and CC.5.2.3.2.

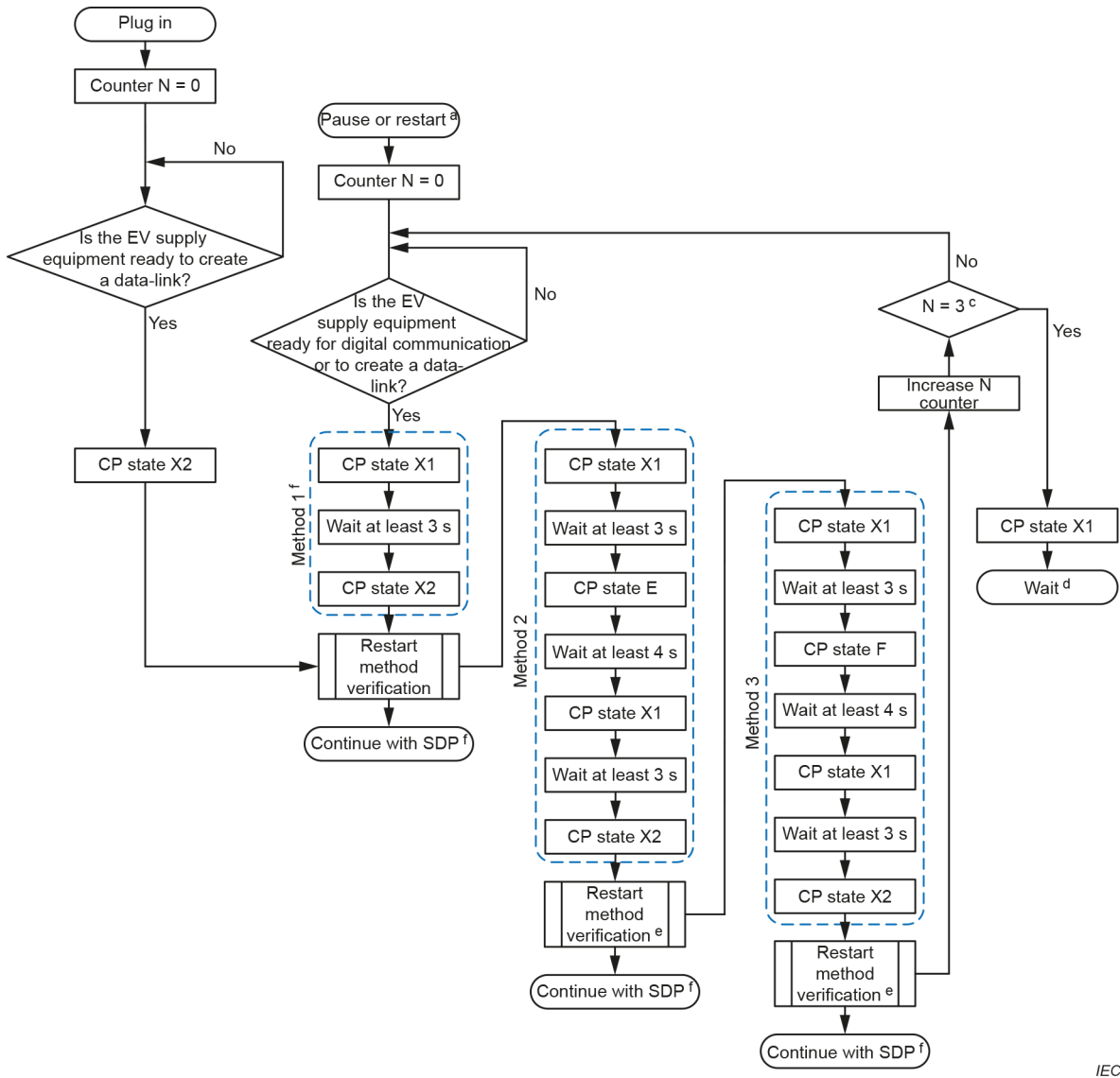

IEC

- <sup>a</sup> The EV can initiate a restart by performing a B – C – B toggle.
- <sup>b</sup> The EV can react by sending a SLAC request (entering the matching process) or an SDP message, which means that the data link is established.
- <sup>c</sup> The EV supply equipment manufacturer can specify a different number of restart cycles.
- <sup>d</sup> The EV supply equipment manufacturer can decide to perform additional restarts, sleep mode or the EV can decide to perform a restart.
- <sup>e</sup> The restart verification method described in Figure CC.16 can either continue with SDP or to the next restart method.
- <sup>f</sup> SECC discovery protocol. See IEC 61851-24.

**Figure CC.15 – Restart methods sequence for the EV supply equipment**

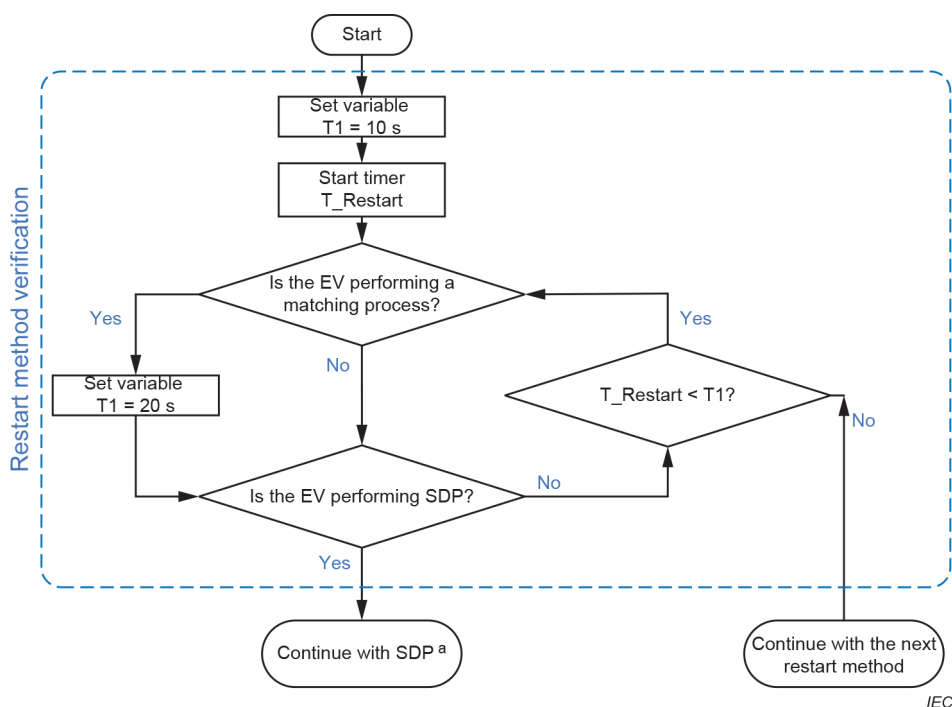

<sup>a</sup> SECC discovery protocol. See IEC 61851-24.

**Figure CC.16 – Restart method verification on the EV supply equipment**

If the EV supply equipment has turned off its CP oscillator, the EV supply equipment shall stay in CP state x1 for 3 s or more according to IEC 61851-1:2017, Table A.6, sequence 9.2.

The EV supply equipment shall wait 10 s or more between restart methods.

NOTE 1 The timeout for the EV supply equipment to receive a matching process request is 20 s for DIN SPEC 70121 and ISO 15118-2:2014. See DIN SPEC 70121:2014, Table 8, and ISO 15118-2:2014, Table 111.

The CP states E or F shall be generated for 4 s or more. See CC.5.2.3.2, restart method 2) and 3).

Unless specified in IEC 61851-24, if a CP state A is detected, the EV supply equipment should

- reset the network membership key (NMK), if it was already used, and
- terminate an established digital communication link.

If a D-LINK\_TERMINATE.request is received, the EV supply equipment should terminate the established digital communication link, unless specified in IEC 61851-24.

Unless specified in IEC 61851-24, if a D-LINK\_TERMINATE.request or a D-LINK\_ERROR.request is received, the EV supply equipment should

- not change the NMK in the next matching process, unless a CP state A is detected, and
- terminate the established digital communication link.

NOTE 2 In ISO 15118, a D-LINK\_TERMINATE.request is sent if message SessionStopReq <10a> contains parameter ChargingSession="Terminate".

In DIN SPEC 70121, the use of D-LINK\_TERMINATE.request is not defined for message SessionStopReq <10a>, meaning the EV or EV supply equipment can choose to terminate the data link or not. It is recommended to keep the data link active.

In ISO 15118-2, a D-LINK\_TERMINATE.request is required to reset the NMK, but for restart purposes and other cases, this can lead to unstable matching processes. The logical network should not change if the CP state does not change to CP state A, as it is the same EV connected to the same EV supply equipment.

### CC.5.2.3.2 Restart methods

If the EV supply equipment wants to restart a communication session, the EV supply equipment shall perform restart method 1), as follows.

- 1) B1 – B2 transition according to IEC 61851-1:2017, Table A.6, sequence 3.1. See the example in Figure CC.17.

NOTE 1 When using DIN SPEC 70121, a communication session restart will generate a new SessionId.

NOTE 2 When using ISO 15118-2:2014, a communication session restart after a pause will maintain the previous SessionId. If a communication session is terminated, a new SessionId will be generated.

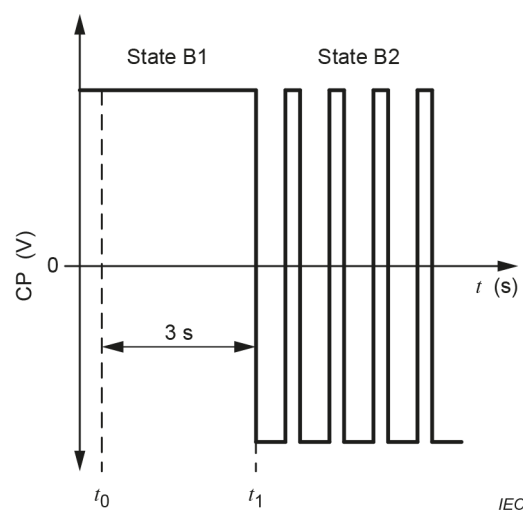

**Figure CC.17 – Example of a B1 – B2 transition**

NOTE 3 ISO 15118-2 and ISO 15118-3 require to skip restart method 1 after an error, for example, receiving a D-LINK\_ERROR.request. This is not recommended, as authentication can be lost when performing restart method 2 or restart method 3 because the EV supply equipment cannot detect an EV disconnection based on CP monitoring. Additionally, monitoring the PP circuit is not a reliable method to determine if the EV is connected, as the EV can turn off the PP voltage source, for example, during sleep mode.

If the EV does not continue with the matching process or SDP when matched after the restart sequence 1 timed out, the EV supply equipment shall perform restart sequence 2, as follows.

- 2) B1 – E – B1 – B2 sequence as described in IEC 61851-1:2017, A.5.3. See the example in Figure CC.18.

NOTE 4 A CP state E requires the EV supply equipment to set  $X_{S1}$  to 0 V DC and without a PWM signal.

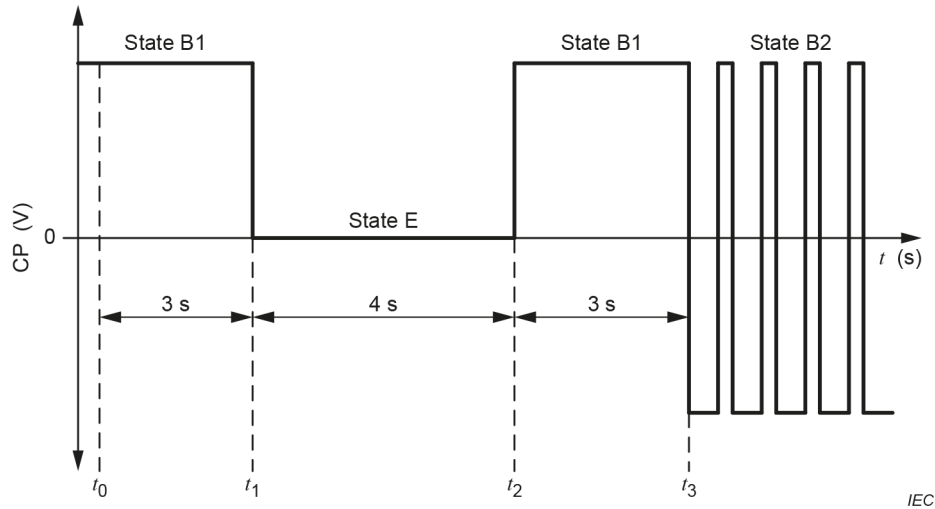
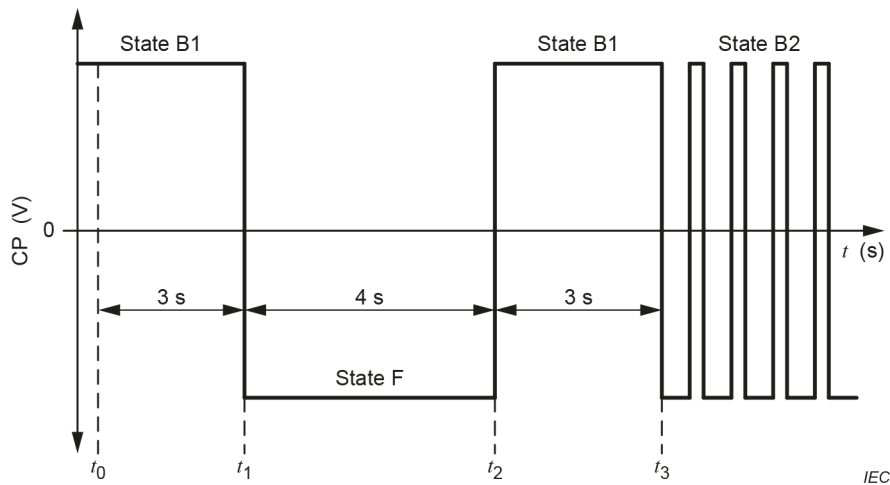

**Figure CC.18 – Example of a B1 – E – B1 – B2 transition**

If the EV does not continue with the matching process or SDP when matched after the restart sequence 2 timed out, the EV supply equipment shall continue with restart sequence 3, as follows.

- 3) B1 – F – B1 – B2 sequence as described in IEC 61851-1:2017, A.5.3. See the example in Figure CC.19.

NOTE 5 A CP state F requires the EV supply equipment to set the  $X_{S1}$  PWM duty cycle to 0 %, generating –12 V DC between CP and PE.



**Figure CC.19 – Example of a B1 – F – B1 – B2 transition**

If the data link is established after one of the restart methods, the EV and EV supply equipment shall

- continue with SDP, or
- restart the matching process with a new SLAC request.

If the data link is not active after performing all the restart methods, the EV supply equipment may perform multiple sequences of the restart methods.

NOTE 6 If using DIN SPEC 70121, see DIN SPEC 70121:2014, 9.6, for additional requirements related to session and error handling.

NOTE 7 If using the ISO 15118 series, see ISO 15118-3:2015, 7.5, and IEC 61851-1:2017, A.5.3, for additional information regarding the restart sequences. See ISO 15118-3:2015, 7.6, for additional requirements related to sleep mode.

#### **CC.5.2.4 Restart by the EV**

The EV shall follow the restart sequence as shown in Figure CC.20.

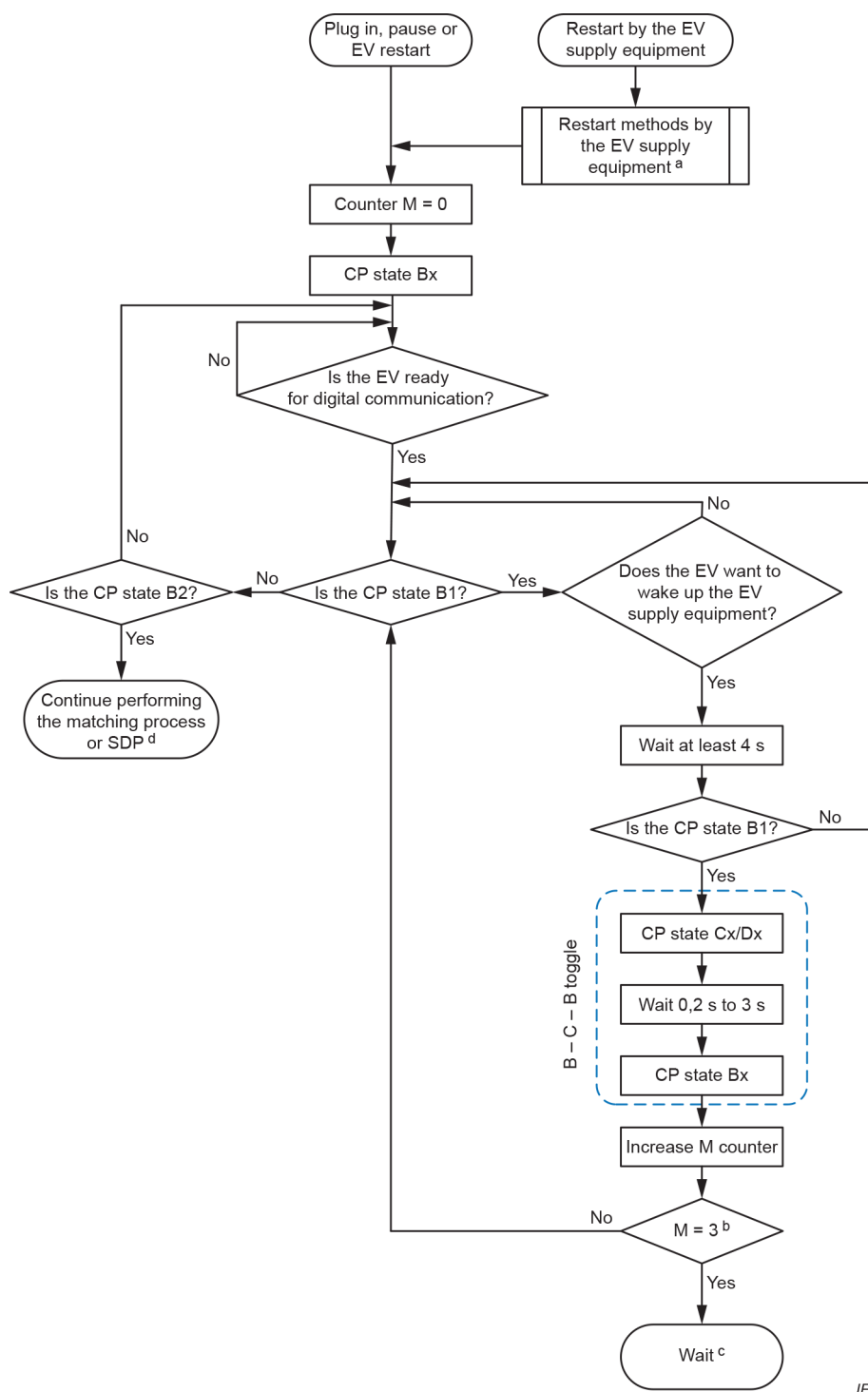

IEC

- <sup>a</sup> The EV supply equipment may perform different restart methods to wake up the EV, according to Figure CC.15
- <sup>b</sup> The EV manufacturer can specify a different number of restart cycles
- <sup>c</sup> The EV manufacturer can perform additional restarts, enter sleep mode or the EV supply equipment can decide to perform a restart
- <sup>d</sup> SECC discovery protocol. See IEC 61851-24.

**Figure CC.20 – Restart methods sequence for the EV**

The EV may restart the digital communication with the EV supply equipment by using a B1 – C1 – B1 or B1 – D1 – B1 toggle according to IEC 61851-1:2017, Table A.6, sequence 11. See the example in Figure CC.21.

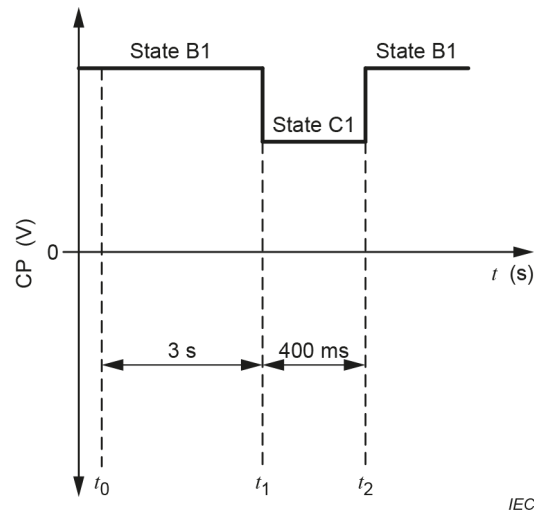

**Figure CC.21 – Example of a B – C – B toggle**

After a successful restart, the EV supply equipment shall enable the CP oscillator with a duty cycle of 5 %.

If the EV supply equipment generated a pause of the communication session (see CC.3.5), the EV shall wait until the EV supply equipment performs a restart method to continue the communication session. The EV is allowed to terminate the communication session while the EV supply equipment is in sleep mode.

NOTE If the EV detects a CP state change from state E to state Bx, where CP state E had a duration more than the 4 s defined for restart method 2, the EV supply equipment might be restarting, for example, due to power loss on side A.

See ISO 15118-3:2015, 7.6, for additional requirements related to sleep mode.

*Compliance is checked by CC.7.6.*

### **CC.5.3 Configuration EE vehicle connector latch position switch ( $S_{S3}$ ) activation**

Latch position switch ( $S_{S3}$ ) of the configuration EE vehicle connector shall not be able to be actuated when the vehicle connector is locked to the vehicle inlet.

NOTE 1 Non-actuation of  $S_{S3}$  in the given tolerances of the latch locking is the responsibility of the vehicle connector manufacturer.

IEC 62196-3:2022, standard sheet 3-IIIc, provides location requirements of the locking device to be used to meet this requirement.

NOTE 2 Due to mechanical tolerances between the vehicle connector and vehicle inlet, it is possible that, while the latch remains locked, the  $S_{S3}$  switch is pressed and detected as open.

### **CC.5.4 Configuration EE vehicle connector latch position switch ( $S_{S3}$ ) verification**

A communication session shall only be allowed once the EV supply equipment has detected that the latch position switch ( $S_{S3}$ ) is in closed position.

If, during a communication session, the EV supply equipment detects the  $S_{S3}$  switch open, the EV supply equipment may consider this event as a stop request from the user.

NOTE 1 SAE J1772:—<sup>9</sup> specifies the PP voltage at the vehicle coupler when the S<sub>S3</sub> switch is closed is between 1,23 V DC and 1,82 V DC. When the S<sub>S3</sub> switch is open, the PP voltage at the vehicle coupler is between 2,38 V DC and 3,16 V DC. See Table CC.3.

NOTE 2 SAE J2953/1:2019 specifies the PP voltage at the vehicle coupler when the S<sub>S3</sub> switch is closed is between 1,30 V DC and 1,72 V DC. When the S<sub>S3</sub> switch is open, the PP voltage at the vehicle coupler is between 2,51 V DC and 3,01 V DC.

NOTE 3 The EV supply equipment can require user authentication to initiate the normal shutdown sequence.

*Compliance is checked by design review to verify that a function is provided to detect the state of S<sub>S3</sub> and prevent the start of a communication session if S<sub>S3</sub> is not in the closed position.*

## CC.5.5 Handling of operating ranges

### CC.5.5.1 General

The target current, target voltage and target power of the EV supply equipment are the intended present current, voltage and power at side B. Depending on the mode (see CC.5.7) and the operating point between the operating range (see 102.2.5), the present current and/or voltage at side B of the EV supply equipment will be at one or more of these targets.

The relationship between the target voltage of the EV and the present voltage at side B is shown in Formula (CC.2), under normal conditions.

$$V_{EVSE\_Out} \leq V_{EVSE\_Target} + |V_{Deviation}| + |V_{Ripple}| \quad (CC.2)$$

where

$V_{EVSE\_Target}$  is the target voltage of the EV supply equipment at side B, expressed in volts;

$V_{EVSE\_Out}$  is the present voltage at side B, expressed in volts;

$V_{Deviation}$  is the deviation on the present voltage at side B as defined in 101.1.2.2, expressed in volts;

$V_{Ripple}$  is the voltage ripple on the present voltage at side B as defined in 101.1.6, expressed in volts.

The relationship between the target current of the EV supply equipment and the present current at side B is shown in Formula (CC.3), under normal conditions and after the control delay specified in 101.1.3.

$$I_{EVSE\_Out} \leq I_{EVSE\_Target} + |I_{Deviation}| + |I_{Ripple}| \quad \text{if } I_{EVSE\_Target} > 0 \text{ A} \quad (CC.3)$$

where

$I_{EVSE\_Target}$  is the target current of the EV supply equipment at side B, expressed in ampere;

$I_{EVSE\_Out}$  is the present current at side B, expressed in ampere;

$I_{Deviation}$  is the deviation on the present current at side B as defined in CC.6.3, expressed in ampere;

<sup>9</sup> Version V8 under preparation.

$I_{\text{Ripple}}$  is the current ripple on the present current at side B as defined in 101.1.5, expressed in ampere.

The relationship between the target power of the EV supply equipment and the present power at side B is under consideration.

#### CC.5.5.2 0 A mode during energy transfer

If the EV supply equipment cannot deliver any current at side B, the EV supply equipment shall send 0 A as its applicable maximum current of the EV supply equipment at side B to the EV within the next communicated message. The 0 A mode initiated by the EV supply equipment shall not trigger an immediate shutdown by the EV. The EV should continue the communication session for 5 min or more.

If the target current of the EV is 0 A DC or the applicable maximum current of the EV supply equipment at side B is 0 A, then the EV supply equipment shall reduce and maintain the present current at side B  $< 0,15$  A DC with a minimum of  $-0,15$  A DC, to prevent RPT from the EV to the EV supply equipment. See Formula (CC.4). See CC.5.5.7 regarding the 0 A target current of the EV and 101.1.3 for the control delay requirements.

NOTE The 0 A mode is used to temporarily continue with the energy transfer phase without a present current at side B. For example, when there are power fluctuations in the supply network, or there is no power available.

The relationship between the target current of the EV supply equipment at side B and the present current at side B is shown in Formula (CC.4), during the 0 A mode and after the control delay specified in 101.1.3.

$$-0,15 \text{ A} \leq I_{\text{EVSE\_Out}} \leq 0,15 \text{ A} \quad (\text{CC.4})$$

if  $I_{\text{EVSE\_Target}} = 0 \text{ A}$

where

$I_{\text{EVSE\_Target}}$  is the target current of the EV supply equipment at side B, expressed in ampere;

$I_{\text{EVSE\_Out}}$  is the present current at side B, expressed in ampere.

#### CC.5.5.3 Changing the applicable maximum voltage of the EV supply equipment at side B

The EV supply equipment shall limit the applicable maximum voltage of the EV supply equipment at side B to the negotiated maximum voltage at side B, as communicated in the last ChargeParameterDiscoveryReq/Res messages. See Formula (CC.5).

$$V_{\text{EVSE\_MAX}} \leq V_{\text{EVSE\_MAX\_CPD}} \quad (\text{CC.5})$$

where

$V_{\text{EVSE\_MAX}}$  is the applicable maximum voltage of the EV supply equipment at side B, expressed in volts;

$V_{\text{EVSE\_MAX\_CPD}}$  is the negotiated maximum voltage at side B, communicated in the last ChargeParameterDiscoveryRes, expressed in volts.

#### **CC.5.5.4 Changing the applicable maximum current of the EV supply equipment at side B**

The present current at side B can be less than the target current of the EV if the applicable maximum current of the EV supply equipment at side B is less than the target current of the EV.

The EV supply equipment shall communicate the change of applicable maximum current of the EV supply equipment at side B in the next communicated message.

The EV supply equipment shall limit the applicable maximum current of the EV supply equipment at side B to the negotiated maximum current at side B which is communicated within the ChargeParameterDiscoveryReq/Res messages. See Formula (CC.6).

$$I_{EVSE\_MAX} \leq I_{EVSE\_MAX\_CPD} \quad (CC.6)$$

where

$I_{EVSE\_MAX}$  is the applicable maximum current of the EV supply equipment at side B, expressed in ampere;

$I_{EVSE\_MAX\_CPD}$  is the negotiated maximum current at side B, communicated in the last ChargeParameterDiscoveryRes message, expressed in ampere.

#### **CC.5.5.5 Changing the applicable maximum power of the EV supply equipment at side B**

The EV supply equipment shall limit the applicable maximum power of the EV supply equipment at side B to the negotiated maximum power at side B, as communicated in the last ChargeParameterDiscoveryReq/Res messages. See Formula (CC.7).

$$P_{EVSE\_MAX} \leq P_{EVSE\_MAX\_CPD} \quad (CC.7)$$

where

$P_{EVSE\_MAX}$  is the applicable maximum power of the EV supply equipment at side B, expressed in watts;

$P_{EVSE\_MAX\_CPD}$  is the negotiated maximum power at side B, communicated in the last ChargeParameterDiscoveryRes message, expressed in watts.

The EV supply equipment is allowed to reduce the present current at side B to less than the target current of the EV if the applicable maximum power of the EV supply equipment at side B drops to a value less than the present power at side B. See CC.5.5.6.

The EV supply equipment shall communicate the change of applicable maximum power of the EV supply equipment at side B in the next communicated message.

#### **CC.5.5.6 The present current at side B is less than the target current of the EV**

The EV shall not trigger a shutdown if the present current at side B is less than the target current of the EV.

NOTE This decrease in present current at side B can be caused by supply network dips, CVM or a change in applicable maximum current of the EV supply equipment at side B. See CC.5.5.4.

**CC.5.5.7 The target current of the EV is less than the applicable minimum current of the EV supply equipment at side B**

The EV supply equipment shall enable 0 A mode (see CC.5.5.2), as if the target current of the EV were 0 A, when the target current of the EV is less than the applicable minimum current of the EV supply equipment at side B. See Formula (CC.8).

$$I_{EVSE\_Target} = 0 \text{ A} \quad (\text{CC.8})$$

$$\text{if } I_{EV\_Req} < I_{EVSE\_MIN}$$

where

$I_{EVSE\_Target}$  is the target current of the EV supply equipment at side B, expressed in ampere;

$I_{EVSE\_MIN}$  is the applicable minimum current of the EV supply equipment at side B, expressed in ampere;

$I_{EV\_Req}$  is the target current of the EV, expressed in ampere

**CC.5.5.8 The target current of the EV is more than the applicable maximum current of the EV supply equipment at side B**

The EV supply equipment shall continue the communication session with the applicable maximum current of the EV supply equipment at side B or the applicable maximum current of the EV, whichever is less, if the target current of the EV is more than the applicable maximum current of the EV supply equipment at side B or the applicable maximum current of the EV. See Formula (CC.9).

$$I_{EVSE\_Target} = \min(I_{EV\_MAX}, I_{EVSE\_MAX}) \quad (\text{CC.9})$$

$$\text{if } I_{EV\_Req} > \min(I_{EV\_MAX}, I_{EVSE\_MAX})$$

where

$I_{EVSE\_Target}$  is the target current of the EV supply equipment at side B, expressed in ampere;

$I_{EVSE\_MAX}$  is the applicable maximum current of the EV supply equipment at side B, expressed in ampere;

$I_{EV\_MAX}$  is the applicable maximum current of the EV, expressed in ampere;

$I_{EV\_Req}$  is the target current of the EV, expressed in ampere.

NOTE The EV can request a target current of the EV higher than the applicable maximum current of the EV supply equipment at side B, to indicate the EV supply equipment that the EV can withstand a higher present current at side B.

**CC.5.5.9 The target voltage of the EV is less than the present voltage at side B**

The EV supply equipment shall enable 0 A mode (see CC.5.5.2), as if the target current of the EV were 0 A, when the target voltage of the EV is less than the present voltage at side B, to prevent RPT (see 101.1). See Formula (CC.10).

$$I_{EVSE\_Target} = 0 \text{ A} \quad (\text{CC.10})$$

if  $V_{EV\_Req} < V_{EVSE\_Out}$

where

$I_{EVSE\_Target}$  is the target current of the EV supply equipment at side B, expressed in ampere;

$V_{EVSE\_Out}$  is the present voltage at side B, expressed in volts;

$V_{EV\_Req}$  is the target voltage of the EV, expressed in volts.

#### CC.5.5.10 The target voltage of the EV is more than the maximum voltage limits

The EV supply equipment shall continue the communication session with the applicable maximum voltage of the EV supply equipment at side B or the target voltage of the EV, whichever is less, if the target voltage of the EV is more than the applicable maximum voltage of the EV supply equipment at side B or the applicable maximum voltage of the EV. See Formula (CC.11).

$$V_{EVSE\_Target} = \min(V_{EV\_Req}, V_{EVSE\_MAX}) \quad (CC.11)$$

if  $V_{EV\_Req} > \min(V_{EV\_MAX}, V_{EVSE\_MAX})$

where

$V_{EVSE\_Target}$  is the target voltage of the EV supply equipment at side B, expressed in volts;

$V_{EVSE\_MAX}$  is the applicable maximum voltage of the EV supply equipment at side B, expressed in volts;

$V_{EV\_Req}$  is the target voltage of the EV, expressed in volts;

$V_{EV\_MAX}$  is the applicable maximum voltage of the EV, expressed in volts.

NOTE The EV supply equipment can remain in CCM until the applicable maximum voltage of the EV is reached. See overvoltage protection in 6.3.1.106, which prevents overcharging the battery system.

#### CC.5.5.11 The present voltage at side B is less than the applicable minimum voltage of the EV supply equipment at side B

The EV supply equipment shall trigger an error shutdown in 50 ms or less if the present voltage at side B or the target voltage of the EV is less than the applicable minimum voltage of the EV supply equipment at side B for more than 3 s. See Formula (CC.12).

Error shutdown if

$$\min(V_{EVSE\_Measured}, V_{EV\_Req}) < V_{EVSE\_MIN} \quad (CC.12)$$

for more than 3 s

where

$V_{EVSE\_Measured}$  is the present voltage at side B, expressed in volts;

$V_{EVSE\_MIN}$  is the applicable minimum voltage of the EV supply equipment at side B, expressed in volts;

$V_{EV\_Req}$  is the target voltage of the EV, expressed in volts.

NOTE This case could be detected during the pre-charge phase, as the EV supply equipment cannot supply the correct present voltage at side B for pre-charge.

#### **CC.5.5.12 The present voltage at side B is more than the applicable maximum voltage of the EV supply equipment at side B**

The EV supply equipment shall trigger an error shutdown in 50 ms or less if the present voltage at side B is more than or equal to the applicable maximum voltage of the EV supply equipment at side B for more than 400 ms, according to 6.3.1.106.3. See Formula (CC.13).

Error shutdown

$$\text{if } V_{EVSE\_Measured} \geq V_{EVSE\_MAX} \quad (\text{CC.13})$$

for more than 400 ms

where

$V_{EVSE\_Measured}$  is the present voltage at side B, expressed in volts;

$V_{EVSE\_MAX}$  is the applicable maximum voltage of the EV supply equipment at side B, expressed in volts.

#### **CC.5.5.13 Limitations due to the applicable minimum power of the EV supply equipment at side B**

The EV supply equipment shall enable 0 A mode (see CC.5.5.2), as if the target current of the EV were 0 A, if

- the target power of the EV is less than the applicable minimum power of the EV supply equipment at side B, or
- for more than 3 s, the present voltage at side B multiplied by the target current of the EV is less than the applicable minimum power of the EV supply equipment at side B.

See Formula (CC.14).

$$I_{EVSE\_Target} = 0 \text{ A if } P_{EV\_Req} < P_{EVSE\_MIN}, \text{ or} \quad (\text{CC.14})$$

$$I_{EVSE\_Target} = 0 \text{ A if } V_{EVSE\_Measured} \times I_{EV\_Req} < P_{EVSE\_MIN} \text{ for more than 3 s}$$

where

$I_{EVSE\_Target}$  is the target current of the EV supply equipment at side B, expressed in ampere;

$I_{EV\_Req}$  is the target current of the EV, expressed in ampere;

$V_{EVSE\_Measured}$  is the present voltage at side B, expressed in volts;

$P_{EV\_Req}$  is the target power requested of the EV, expressed in watts;

$P_{EVSE\_MIN}$  is the applicable minimum power of the EV supply equipment at side B, expressed in volts.

NOTE  $P_{EVSE\_MIN}$  is the internal minimum power that the EV supply equipment can deliver, as this value is not handled by the digital communication, but is restricting the present power at side B. The EV supply equipment cannot know the minimum voltage and the present voltage of the battery system, as these are not communicated through digital communication.

#### CC.5.5.14 Limitations due to the applicable maximum power of the EV supply equipment at side B

If the target power of the EV, or target current of the EV multiplied by the present voltage at side B, or target current of the EV multiplied by the target voltage of the EV, that is more than the applicable maximum power of the EV or the applicable maximum power of the EV supply equipment at side B, then the EV supply equipment shall continue the communication session and limit the target power of the EV supply equipment at side B to the minimum of the following values:

- applicable maximum power of the EV;
- applicable maximum power of the EV supply equipment at side B.

See Formula (CC.15).

$$P_{EVSE\_Target} = \min(P_{EV\_MAX}, P_{EVSE\_MAX}) \text{ if } \min(V_{EVSE\_Measured} \times I_{EV\_Req}, V_{EV\_Req} \times I_{EV\_Req}, P_{EV\_Req}) > \min(P_{EV\_MAX}, P_{EVSE\_MAX}) \quad (CC.15)$$

$$\text{with } P_{EV\_MAX} = \max(P_{EV\_MAX\_CPD}, V_{EV\_MAX\_CPD} \times I_{EV\_MAX\_CPD})$$

where

$V_{EVSE\_Measured}$	is the present voltage at side B, expressed in volts;
$V_{EV\_Req}$	is the target voltage of the EV, expressed in volts;
$I_{EV\_Req}$	is the target current of the EV, expressed in amperes;
$P_{EVSE\_Target}$	is the target power of the EV supply equipment at side B, expressed in watts;
$P_{EVSE\_MAX}$	is the applicable maximum power of the EV supply equipment at side B, expressed in watts;
$P_{EV\_Req}$	is the target power of the EV, expressed in watts;
$P_{EV\_MAX}$	is the applicable maximum power of the EV, expressed in watts;
$V_{EV\_MAX\_CPD}$	is the rated maximum voltage of the EV in ChargeParameterDiscoveryReq, expressed in volts;
$I_{EV\_MAX\_CPD}$	is the rated maximum current of the EV in ChargeParameterDiscoveryReq, expressed in ampere;
$P_{EV\_MAX\_CPD}$	is the rated maximum power of the EV in ChargeParameterDiscoveryReq, expressed in watts.

NOTE 1  $P_{EV\_MAX\_CPD} = 0$  if  $P_{EV\_MAX\_CPD}$  is not communicated by the EV.

NOTE 2 According to ISO 15118-2,  $P_{EV\_Req}$  is the "EVMaximumPowerLimit" within the CurrentDemandReq messages and  $P_{EV\_MAX}$  is the "EVMaximumPowerLimit" communicated.

NOTE 3 Lowering the present power at side B can be achieved by limiting the target current of the EV supply equipment at side B based on the present voltage at side B and the target power of the EV supply equipment at side B, as the CPM is not defined for system C. See also CC.5.5.4 and CC.5.5.6.

### CC.5.6 Compatibility check

During the compatibility check, the EV and EV supply equipment exchange ChargeParameterDiscoveryReq/Res messages. Both the EV and EV supply equipment validate the received messages. The EV and EV supply equipment may need to send multiple messages to update the parameters.

The value in parameter "EVSEProcessing", sent by the EV supply equipment in message ChargeParameterDiscoveryRes <3b>, depends on the following.

- a) Ongoing: If the EV supply equipment needs more time to complete the compatibility check.
- b) Finished: The EV supply equipment has finished the compatibility check.

The value in parameter "ResponseCode", sent by the EV supply equipment in message ChargeParameterDiscoveryRes <3b>, depends on the following.

- c) OK: No error.
- d) FAILED\_WrongChargeParameter: Error message to indicate that the EV and EV supply equipment are not compatible.
- e) FAILED\_X: Error message by another cause.

The EV should perform its own compatibility check based on the parameters communicated by the EV supply equipment in message ChargeParameterDiscoveryRes <3b>. If one of the following conditions is not met, the EV can either maintain or update the values sent to the EV supply equipment to reach compatibility:

- f)  $V_{EV\_MAX\_CPD} \geq V_{EVSE\_MIN\_CPD}$ ;
- g)  $I_{EV\_MAX\_CPD} \geq I_{EVSE\_MIN\_CPD}$ ;
- h)  $P_{EV\_MAX\_CPD} \geq P_{EVSE\_MIN\_CPD}$ .

The message sequence for the compatibility check, based on ISO 15118-2:2014 and DIN SPEC 70121:2014, is described in the following steps.

- 1) The EV shall send a ChargeParameterDiscoveryReq <3a> message using the rated maximum voltage, current and power of the EV:
  - a)  $V_{EV\_MAX\_CPD} = V_{EV\_MAX\_RATED}$ ;
  - b)  $I_{EV\_MAX\_CPD} = I_{EV\_MAX\_RATED}$ ;
  - c)  $P_{EV\_MAX\_CPD} = P_{EV\_MAX\_RATED}$ .
- 2) When a ChargeParameterDiscoveryReq <3a> message is received by the EV supply equipment, the EV supply equipment shall send a ChargeParameterDiscoveryRes <3b> message, based on the values received in the previous ChargeParameterDiscoveryReq <3a> message, with the following parameters.
  - a) If  $V_{EV\_MAX\_CPD} \leq 500$  V:
 
$$V_{EVSE\_MAX\_CPD} \leq \min(V_{EV\_MAX\_CPD} + 50 \text{ V}, V_{EVSE\_MAX\_RATED}, 500 \text{ V}).$$
 If  $V_{EV\_MAX\_CPD} > 500$  V:
 
$$V_{EVSE\_MAX\_CPD} \leq \min(1,1 \times V_{EV\_MAX\_CPD}, V_{EVSE\_MAX\_RATED}).$$
  - b)  $I_{EVSE\_MAX\_CPD} \leq \min(I_{EV\_MAX\_CPD}, I_{EVSE\_MAX\_RATED})$ .
  - c)  $P_{EVSE\_MAX\_CPD} \leq \min(P_{EV\_MAX}, P_{EVSE\_MAX\_RATED})$  where:
    - if  $P_{EV\_MAX}$  is not communicated by the EV or  $P_{EV\_MAX}$  is 0, then
 
$$P_{EV\_MAX} = \max(V_{EV\_MAX\_CPD} \times I_{EV\_MAX\_CPD}, 200 \text{ kW}), \text{ or}$$

- if  $P_{EV\_MAX}$  is communicated by the EV and  $P_{EV\_MAX}$  is not 0, then

$$P_{EV\_MAX} = P_{EV\_MAX\_CPD}$$

NOTE 1 Setting the rated maximum power of the EV to 200 kW improves interoperability with EVs based on IEC 61851-23:2014.

d)  $V_{EVSE\_MIN\_CPD} = V_{EVSE\_MIN\_RATED}$

e)  $I_{EVSE\_MIN\_CPD} = I_{EVSE\_MIN\_RATED}$

f)  $P_{EVSE\_MIN\_CPD} = P_{EVSE\_MIN\_RATED}$

NOTE 2  $P_{EVSE\_MIN\_CPD}$  is not covered by some digital communication standards.

- g) Parameters EVSEProcessing, EVSEStatusCode and ResponseCode are based on the following conditions.

- $V_{EVSE\_MIN\_RATED} < V_{EV\_MAX\_CPD}$

- $I_{EVSE\_MIN\_RATED} < I_{EV\_MAX\_CPD}$

- If  $P_{EV\_MAX\_CPD}$  is not communicated by the EV or  $P_{EV\_MAX\_CPD}$  is 0, then

$$P_{EVSE\_MIN\_RATED} < \max(V_{EV\_MAX\_CPD} \times I_{EV\_MAX\_CPD}, 200 \text{ kW}), \text{ or}$$

- If  $P_{EV\_MAX\_CPD}$  is communicated by the EV and  $P_{EV\_MAX\_CPD}$  is not 0, then

$$P_{EVSE\_MIN\_RATED} < P_{EV\_MAX\_CPD}$$

- i) If any of the above conditions are not met, the EV supply equipment shall

- set "EVSEProcessing" = 'Finished',
- set "EVSEStatusCode" = 'EVSE\_Shutdown',
- set "ResponseCode" = 'FAILED\_WrongChargeParameter', and
- trigger an error shutdown according to CC.3.4 and IEC 61851-24.

NOTE 3 A message with "ResponseCode" = 'FAILED\_' ends the compatibility check and triggers an error shutdown.

- ii) If all the conditions above are met and the EV supply equipment has detected an error, the EV supply equipment shall

- set "EVSEProcessing" = 'Finished'
- set "EVSEStatusCode" = 'EVSE\_Shutdown'
- set "ResponseCode" = 'FAILED' (unless a specific error requires another value), and
- trigger an error shutdown according to CC.3.4 and IEC 61851-24.

- iii) If all the conditions above are met and the EV supply equipment does not have to update its energy transfer parameters, does not have to remain in the ChargeParameterDiscovery cycle, and has not detected an error, the EV supply equipment shall

- set "EVSEProcessing" = 'Finished'
- set "EVSEStatusCode" = 'EVSE\_IsolationMonitoringActive', or 'EVSE\_Shutdown' (in case of an error),
- set "ResponseCode" = 'OK', and
- continue with step 5) in this sequence.

- iv) If all the conditions above are met, but the EV supply equipment needs to update its energy transfer parameters at a later time, the EV supply equipment shall

- set "EVSEProcessing" = 'Ongoing',
- set "EVSEStatusCode" = 'EVSE\_IsolationMonitoringActive', or 'EVSE\_Shutdown' (in case of an error),

- set "ResponseCode" = 'OK', and
- continue with step 3) in this sequence.

Messages with parameters "EVSEProcessing" = 'Ongoing' and "ResponseCode" = 'OK' allow to continue with cyclic ChargeParameterDiscoveryReq/Res messages.

If the EV supply equipment compatibility check results in a "failed compatibility check", the EV supply equipment shall send at least one ChargeParameterDiscoveryRes <3b> message with parameters "EVSEProcessing" = 'Ongoing' and "ResponseCode" = 'OK' with the proposed negotiated values before the EV supply equipment rejects the communication session.

This enables the EV and the EV supply equipment to update their energy transfer parameters, if necessary. The EV supply equipment may require cyclic ChargeParameterDiscoveryReq/Res messages while it waits to update its rated limits or other reasons. For example, waiting for load management controls, vehicle connector locking issues, etc.

- h) If the EV supply equipment wants to trigger a pause before cable-check phase, as it cannot perform the cable-check phase at this moment in time, the EV supply equipment shall, in parameter "EVSEStatus",
- set "EVSENotification" = 'StopCharging', and
  - set "NotificationMaxDelay" = 0.

See also CC.3.5.2.

- i) If the EV supply equipment wants to trigger a pause before energy transfer and can perform the cable-check phase, the EV supply equipment shall, in parameter "EVSEStatus",
- set "EVSENotification" = 'StopCharging', and
  - set "NotificationMaxDelay" > 0.

It is recommended to use 300 s for the "NotificationMaxDelay".

See also CC.3.5.3.

- j) If the EV supply equipment wants to perform a normal communication session, the EV supply equipment shall, in parameter "EVSEStatus",
- set "EVSENotification" = 'None', and
  - set "NotificationMaxDelay" = 0.

See also CC.3.2.

- 3) When the EV receives a ChargeParameterDiscoveryRes <3b> message with parameter "EVSE\_Processing" = 'Ongoing', the EV shall send a ChargeParameterDiscoveryReq <3a> message (if necessary, the EV may update the parameters in this ChargeParameterDiscoveryReq <3a> message, based on the values received in the previous ChargeParameterDiscoveryRes <3b> message), with the following conditions.

a)  $V_{EVSE\_MIN\_CPD} < V_{EV\_MAX\_CPD} \leq V_{EV\_MAX\_RATED}$ .

b)  $I_{EVSE\_MIN\_CPD} < I_{EV\_MAX\_CPD} \leq I_{EV\_MAX\_RATED}$ .

c)  $P_{EVSE\_MIN\_CPD} < P_{EV\_MAX\_CPD} \leq P_{EV\_MAX\_RATED}$ .

NOTE 4  $P_{EVSE\_MIN\_CPD}$  is not covered by some digital communication standards and is considered as 0 kW in this case.

NOTE 5 The EV can require updating its energy transfer parameters in case it can support present voltages at side B < 500 V DC and > 500 V DC. For example, some EVs support energy transfer with an EV supply equipment capable of 500 V DC or 1 000 V DC at side B, meaning the EV could successfully complete the compatibility check by using an internal DC/DC PEC or a switching matrix to change the present voltage of the battery system voltage at side B.

According to DIN SPEC 70121:2014, the EV shall resend the identical ChargeParameterDiscoveryReq messages. However, it is recommended for the EV supply equipment not to perform a shutdown if the EV changes the parameters.

The EV sends the parameters that result in the highest FPT power in the first ChargeParameterDiscoveryReq <3a> message. If the EV supply equipment responds with incompatible values (for example, a rated maximum voltage of the EV supply equipment at side B less than the present voltage of the battery system), the EV should update the parameters with compatible values within its capabilities in the next ChargeParameterDiscoveryReq <3a> message.

If updating the parameters is not possible or necessary, the EV shall send the same parameter values as in the previous ChargeParameterDiscoveryReq <3a> message.

- 4) The EV and EV supply equipment shall continue to send cyclic ChargeParameterDiscoveryReq/Res messages to update the parameters (if necessary), complying with the timing requirements (for example, digital communication timeouts) of the selected digital communication standard.

Resume at step 2) in this sequence.

- 5) After the EV supply equipment has sent its definitive values for the parameters in message ChargeParameterDiscoveryRes <3b> with "EVSEProcessing" = 'Finished', the EV shall verify that, before sending the CableCheckReq <4a>, the values in the response message comply with the following conditions.

a)  $V_{EVSE\_MIN\_CPD} \leq V_{Battery} < V_{EVSE\_MAX\_CPD}$ .

NOTE 6  $V_{Battery}$  could be less than the present voltage of the battery system if the EV supports energy transfer with a lower present voltage at side B. For example, by using a DC/DC PEC.

b)  $I_{EVSE\_MIN\_CPD} \leq I_{EV\_MIN\_RATED} \leq I_{EVSE\_MAX\_CPD}$ .

c)  $P_{EVSE\_MIN\_CPD} \leq P_{EV\_MIN\_RATED} \leq P_{EVSE\_MAX\_CPD}$ .

d) "ResponseCode" = 'OK'.

If the conditions are not met, then the EV shall trigger an error shutdown according to CC.3.4 and IEC 61851-24.

The applicable maximum values sent in CurrentDemandRes <7b> messages during energy transfer shall be less than or equal to the negotiated maximum values sent by the EV supply equipment in the last ChargeParameterDiscoveryRes <3b> message.

If the EV supply equipment sent ChargeParameterDiscoveryRes <3b> with parameters:

- "EVSENotification" = 'StopCharging',
- "NotificationMaxDelay" = '0',
- "EVSEProcessing" = 'Finished' and
- "ResponseCode" = 'OK'

and meets all conditions 5) a), b), c), d), then the EV shall not send messages CableCheckReq <4a> and PreChargeReq <5a>, but instead the EV shall

- if using ISO 15118-2:2014: send message PowerDeliveryReq <6a> with "ChargeProgress" = 'Stop' as the next message to skip the cable-check and pre-charge phases (see also CC.3.5.2), or
- if using DIN SPEC 70121:2014: send message SessionStopReq <10a> as the next message to skip the cable-check and pre-charge phases (see also CC.3.5.2).

EV supply equipment parameters used in 1) to 5):

$V_{EVSE\_MAX\_RATED}$ : rated maximum voltage of the EV supply equipment at side B

$I_{EVSE\_MAX\_RATED}$ : rated boost current of the EV supply equipment at side B

$P_{EVSE\_MAX\_RATED}$ : rated maximum power of the EV supply equipment at side B

$V_{EVSE\_MIN\_RATED}$ : rated minimum voltage of the EV supply equipment at side B

$I_{EVSE\_MIN\_RATED}$ : rated minimum current of the EV supply equipment at side B

$P_{EVSE\_MIN\_RATED}$ : rated minimum power of the EV supply equipment at side B

$V_{EVSE\_MAX\_CPD}$ :	maximum voltage of the EV supply equipment at side B communicated in ChargeParameterDiscoveryRes (for example, EVSEMaximumVoltageLimit in ISO 15118-2:2014 and DIN SPEC 70121:2014)
$I_{EVSE\_MAX\_CPD}$ :	maximum current of the EV supply equipment at side B communicated in ChargeParameterDiscoveryRes (for example, EVSEMaximumCurrentLimit in ISO 15118-2:2014 and DIN SPEC 70121:2014)
$P_{EVSE\_MAX\_CPD}$ :	maximum power of the EV supply equipment at side B communicated in ChargeParameterDiscoveryRes (for example, EVSEMaximumPowerLimit in ISO 15118-2:2014 and DIN SPEC 70121:2014)
$V_{EVSE\_MIN\_CPD}$ :	minimum voltage of the EV supply equipment at side B communicated in ChargeParameterDiscoveryRes (for example, EVSEMinimumVoltageLimit in ISO 15118-2:2014 and DIN SPEC 70121:2014)
$I_{EVSE\_MIN\_CPD}$ :	minimum current of the EV supply equipment at side B communicated in ChargeParameterDiscoveryRes (for example, EVSEMinimumCurrentLimit in ISO 15118-2:2014 and DIN SPEC 70121:2014)
$P_{EVSE\_MIN\_CPD}$ :	minimum power of the EV supply equipment at side B communicated in ChargeParameterDiscoveryRes

NOTE 7  $P_{EVSE\_MIN\_CPD}$  is not covered by some digital communication standards.

EV parameters used in 1) to 5):

$V_{EV\_MAX\_RATED}$ :	rated maximum voltage of the EV
$V_{Battery}$ :	present voltage of the battery system
$I_{EV\_MAX\_RATED}$ :	rated maximum current of the EV
$I_{EV\_MIN\_RATED}$ :	rated minimum current of the EV
$P_{EV\_MAX}$ :	maximum power of the EV
$P_{EV\_MAX\_RATED}$ :	rated maximum power of the EV
$P_{EV\_MIN\_RATED}$ :	rated minimum power of the EV
$V_{EV\_MAX\_CPD}$ :	maximum voltage of the EV in ChargeParameterDiscoveryReq (for example, EVMaximumVoltageLimit in ISO 15118-2:2014 and DIN SPEC 70121:2014)
$I_{EV\_MAX\_CPD}$ :	maximum current of the EV in ChargeParameterDiscoveryReq (for example, EVMaximumCurrentLimit in ISO 15118-2:2014 and DIN SPEC 70121:2014)
$P_{EV\_MAX\_CPD}$ :	maximum power of the EV in ChargeParameterDiscoveryReq (for example, EVMaximumPowerLimit in ISO 15118-2:2014 and DIN SPEC 70121:2014)

### CC.5.7 Considerations for CCM, CVM and CPM (informative)

The EV supply equipment requires to use CCM, CVM or CPM energy transfer control modes at different stages/phases of the communication session. The EV supply equipment will select the energy transfer control mode based on the applicable maximum voltage, current and power values and target voltage, current and power of the EV. The energy transfer control modes, based on the digital communication messages and communication session stage/phase, are defined in Table CC.20.

**Table CC.20 – Energy transfer control modes at different communication session stage/phase**

	CCM	CPM	CVM
Cable-check phase			X
Pre-charge phase			X
Energy transfer stage	X	X	X

The EV supply equipment can only work in one energy transfer control mode at the time. This means that the uncontrolled target value will vary according to the physical characteristics of the side B. For example, if the EV supply equipment is in CCM, the present voltage at side B will be the present voltage of the battery system plus the voltage drop between the side B cable assembly, vehicle inlet and conductor impedances to the battery system. In CVM, the present current at side B will depend on the impedance seen by the EV supply equipment at the vehicle connector. If the EV disconnection device is closed, the impedance at the vehicle connector will vary with the internal battery system resistance, X-capacitance, Y-capacitance, side B cable assembly impedance, impedance of the internal DC conductors of the EV, additional accessories connected to the side B during energy transfer, among other parameters.

During cable-check phase and pre-charge phase, the limits of the present current at side B are defined in CC.4.1.2 and CC.5.1, respectively. If a higher present current at side B is needed due to the load or errors on side B, then the EV supply equipment switches to CCM to fulfil the limitation requirements for the present current at side B.

Changing between CCM, CVM, and CPM may cause unwanted high current spikes and ripples at the present current at side B due to the switching of the control loops. Specific requirements to limit these spikes, due to mode switching, are under consideration.

For FPT to a battery system, it is good practice that the EV puts the EV supply equipment in CCM. Then, the EV controls the target current of the EV based on its internal CVM, as the EV has full control of the present current at side B until the end of the communication session.

If the target voltage of the EV is within the switch over border between CCM and CVM (meaning it is unclear if the EV supply equipment is in CCM or CVM), then, depending on the deviation of the present voltage at side B, it is possible that the battery system voltage does not reach the target voltage of the EV, or the battery system voltage can be more than the target voltage of the EV, as long as the present voltage at side B is less than the rated maximum voltage of the EV. See 101.1.2.2 for the requirements of the voltage deviation at side B and CC.6.4 for the measurement accuracy.

When the EV supply equipment and the EV are in the same control mode (CVM or CCM) at the same time, the two control loops will try to regulate the target current/voltage of the EV supply equipment at side B with the present current/voltage at side B and the target current/voltage of the EV, respectively. This may cause unstable control loops and result in large deviation and ripple in the present current at side B.

As described in 101.1.2.2, to ensure that the EV supply equipment stays in CCM, the target voltage of the EV should be far from the border of the CVM, otherwise the EV supply equipment may switch to CVM. Depending on the ripple, side B deviations and other effects, the EV supply equipment can keep switching between CCM and CVM when the target voltage/current of the EV are at the switching borders of the different modes.

The range where the EV supply equipment can stay in the CCM is defined by the formula in 101.1.2.2.

## CC.6 Specific requirements

### CC.6.1 Requirements for load dump

In case of a load dump, after the first 3 ms, the voltage overshoot at side B between DC+ and DC– shall be less than or equal to

- for a rated maximum voltage of the EV, as communicated (in the last request message before  $t_3$ ) during the initialization phase,  $> 500$  V: 110 % of the rated maximum voltage of the EV, or
- for a rated maximum voltage of the EV, as communicated (in the last request message before  $t_3$ ) during the initialization phase,  $\leq 500$  V: rated maximum voltage of the EV plus 50 V.

See Formula (CC.16).

$$V_{EVSE\_Out} \leq \max(110 \% \times V_{EV\_MAX\_CPD}, V_{EV\_MAX\_CPD} + 50 \text{ V}) \quad (\text{CC.16})$$

where

$V_{EVSE\_Out}$  is the present voltage at side B, expressed in volts;

$V_{EV\_MAX\_CPD}$  is the maximum voltage of the EV, communicated in the last ChargeParameterDiscoveryReq message, expressed in volts.

*Compliance is checked by CC.7.6.7.*

### CC.6.2 Side B current regulation

When in CCM, the EV supply equipment shall control the present current at side B. The maximum allowable deviation between the present current at side B and the target current of the EV is:

- $\pm 150$  mA DC when the target current of the EV is  $< 5$  A DC;
- $\pm 1,5$  A DC when the target current of the EV is  $\geq 5$  A DC but  $\leq 50$  A DC;
- $\pm 3$  % of the target current of the EV when the target current of the EV is  $> 50$  A DC.

If the accuracy requirements cannot be met for the lowest currents, the applicable minimum current of the EV supply equipment at side B may be set to values where the EV supply equipment can meet the requirements. If the target current of the EV is less than the applicable minimum current of the EV supply equipment at side B, see CC.5.5.7.

*Compliance is checked by CC.7.6.9.*

### CC.6.3 Measuring current and voltage at side B

The accuracy of side B voltage and current measurements of system C shall be between the following values:

- measured voltage at side B: between  $\pm 10$  V DC;
- measured current at side B: between  $\pm 1,5$  % of the measured current at side B or between  $\pm 0,5$  A, whichever is more.

*Compliance is checked by design review.*

The time between measuring voltage and current at side B and communicating them to the EV should be less than or equal to 200 ms. The EV should not solely rely on the voltage and current measurements from the EV supply equipment at side B to control the communication session.

#### CC.6.4 Overcurrent protection of side B

The EV supply equipment shall provide an overcurrent protection to protect the side B.

If one or both of the following conditions are continuously fulfilled for a duration of 0,5 s, the EV supply equipment shall trigger an emergency shutdown in 0,5 s or less:

- the present current at side B is more than 120 % of the applicable maximum current of the EV supply equipment at side B;
- during energy transfer, the present voltage at side B is less than 80 % of the applicable minimum voltage of the EV supply equipment at side B.

NOTE For the protective measures in the EV, see ISO 17409:2020, 6.2.

*Compliance is checked by design review.*

#### CC.7 General test conditions

##### CC.7.1 Operating points – Definitions

Definitions of variables are as follows:

- $V_{EV\_target}$ : target voltage of the EV simulator, sent to the EV supply equipment via digital communication;
- $I_{EV\_target}$ : target current of the EV simulator, sent to the EV supply equipment via digital communication;
- $V_{EVSE\_SideB}$ : voltage at side B measured by the EV simulator;
- $I_{EVSE\_SideB}$ : current at side B measured by the EV simulator;
- $V_{EV\_max}$ : rated maximum voltage of EV simulator;
- $I_{EV\_max}$ : rated maximum current of EV simulator.

The values for  $V_{EV\_max}$  and  $I_{EV\_max}$  shall be set to the maximum corresponding values of the EV supply equipment transferred via digital communication (for example, ChargeParameterDiscoveryRes) unless otherwise specified.

All digital communication shall be according to IEC 61851-24, which includes the applicable standards DIN SPEC 70121:2014 and ISO 15118-2:2014.

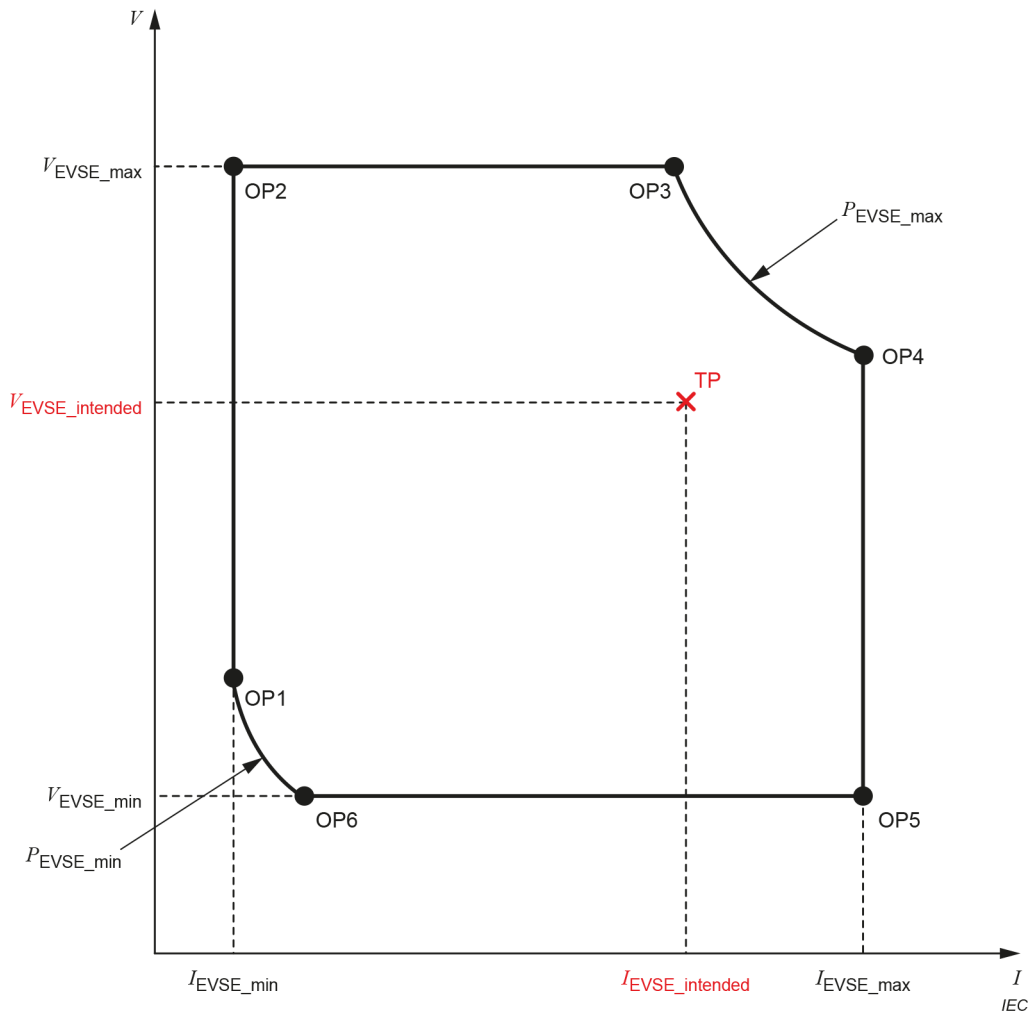

### Key

$I_{EVSE\_max}$	rated boost/continuous current of the EV supply equipment at side B	OP1	$I_{EVSE\_min}$ and $P_{EVSE\_min}$
$I_{EVSE\_min}$	rated minimum current of the EV supply equipment at side B	OP2	$V_{EVSE\_max}$ and $I_{EVSE\_min}$
$I_{EVSE\_intended}$	target current of the EV supply equipment at side B for the test point TP	OP3	$V_{EVSE\_max}$ and $P_{EVSE\_max}$
$V_{EVSE\_max}$	rated maximum voltage of EV supply equipment at side B	OP4	$I_{EVSE\_max}$ and $P_{EVSE\_max}$
$V_{EVSE\_min}$	rated minimum voltage of EV supply equipment at side B	OP5	$V_{EVSE\_min}$ and $I_{EVSE\_max}$
$V_{EVSE\_intended}$	target voltage of the EV supply equipment at side B for the test point TP	OP6	$V_{EVSE\_min}$ and $P_{EVSE\_min}$
$P_{EVSE\_max}$	rated maximum power of the EV supply equipment at side B	TP	$V_{EVSE\_intended}$ and $I_{EVSE\_intended}$
$P_{EVSE\_min}$	rated minimum power of the EV supply equipment at side B		

**Figure CC.22 – Operating points**

The defined operating range (OP1 to OP6) specifies the possible range of values of target voltage and current of the EV. Between the tolerances, the EV supply equipment however may deliver values for current or voltage that are outside of this operating range.

The actual shape of the operating range may differ from the idealized shape as depicted in Figure CC.22 (for example, caused by flexible configuration of multiple PECs). Furthermore, the operating range of the EV supply equipment may dynamically change during the energy transfer stage, for example, due to thermal degradation.

For digital communication according to DIN SPEC 70121 and ISO 15118-2, both operating points OP1 and OP6 as shown above denote the same operating point (OP1 = OP6) and

$$P_{EVSE\_min} = V_{EVSE\_min} \times I_{EVSE\_min}$$

A test point TP defines the intended operating voltage and operating current which is needed to run a specific test.

### CC.7.2 Standard test setup

Figure 131 shows the standard test setup for system C.

### CC.7.3 Definition of measured values at side B

The measured values at side B are defined as follows:

- $V_{EVSE\_SideB\_DC}$ : measured voltage at side B  $V_{EVSE\_SideB}$  averaged (RMS or mean) over a measurement duration of 1 s or more;
- $V_{EVSE\_rip}$ : absolute maximum limit in  $V_{peak-to-peak}$  of all voltage ripple components of the measured voltage at side B  $V_{EVSE\_SideB}$  in the frequency range < 150 kHz;
- $I_{EVSE\_SideB\_DC}$ : present current at side B  $I_{EVSE\_SideB}$  averaged (RMS or mean) over a measurement duration of 1 s or more;
- $I_{rip\_low}$ : absolute maximum limit in  $A_{peak-to-peak}$  of all current ripple components of the measured current at side B  $I_{EVSE\_SideB}$  in the frequency range < 10 Hz;
- $I_{rip\_mid}$ : absolute maximum limit in  $A_{peak-to-peak}$  of all current ripple components of the measured current at side B  $I_{EVSE\_SideB}$  in the frequency range < 5 kHz;
- $I_{rip\_high}$ : absolute maximum limit in  $A_{peak-to-peak}$  of all current ripple components of the measured current at side B  $I_{EVSE\_SideB}$  in the frequency range < 150 kHz.

For ripple components, all filtering shall be done with a first order filter, and the values shall be measured over a duration of 10 s or more.

### CC.7.4 Exemplary approach to set a test point in CCM

In order to approach a specific test point TP in CCM, the following steps shall be taken. The step numbers refer to Figure CC.23 and Figure CC.24:

Step 1:

- a) Set  $U_{T4} = V_{Pre-charge}$  and close  $S_{T19}$ .

It is recommended to choose  $V_{Pre-charge}$  in such a way that

- $V_{EVSE\_min} \leq V_{Pre-charge} \leq V_{EVSE\_max}$ ,
- $V_{EVSE\_SideB}$  does not leave the operating range of the EV supply equipment during step 2, and
- the difference between  $V_{EVSE\_SideB}$  and  $V_{EVSE\_intended}$  after step 2 is small. With that, the need to adjust  $U_{T4}$  in step 3 will also be small.

b) Based on the data sheet of the EV supply equipment, the EV simulator shall communicate the following properties with the message "ChargeParameterDiscoveryReq" <3a>:

- $V_{EV\_max} = 1,2 \times V_{EVSE\_max}$ ;
- $V_{EV\_min} = 0,8 \times V_{EVSE\_min}$ ;
- $I_{EV\_max} = 1,2 \times I_{EVSE\_max}$ ;
- $I_{EV\_min} = 0,8 \times I_{EVSE\_min}$ ;
- $P_{EV\_max} = 1,2 \times P_{EVSE\_max}$ .

The EV supply equipment shall have successfully communicated the following properties to the EV simulator with the message "ChargeParameterDiscoveryRes" <3b>:

- $V_{EVSE\_min}$ ;
- $V_{EVSE\_max}$ ;
- $I_{EVSE\_min}$ ;
- $I_{EVSE\_max}$ ;
- $P_{EVSE\_max}$ .

c) Continue the normal startup sequence up to  $t = t_9$ . Then close  $S_{T17}$  and  $S_{T18}$ . Continue the normal startup sequence until the EV supply equipment has communicated that it is ready for energy transfer with the message "PowerDeliveryRes" <6b> (that is, between  $t = t_9$  and  $t = t_{11}$  according to CC.3.2).

Use the following parameter in the message "PreChargeReq" <5a>:  
 $EVTARGETVOLTAGE = V_{EV\_target} = V_{Pre\text{-}charge}$

Step 2:

a) Request target values with the following parameters in the message "CurrentDemandReq" <7a> according to DIN SPEC 70121:2014 or ISO 15118-2:2014:

- $EVTARGETCURRENT = I_{EV\_target} = I_{EVSE\_intended}$ ;
- $EVTARGETVOLTAGE = V_{EV\_target} = 1,2 \times V_{EVSE\_max}$  (to allow for CCM);
- $EVMAXIMUMVOLTAGELIMIT = V_{EV\_max}$ .

The EV simulator shall periodically issue target current and target voltage requests in the message "CurrentDemandReq" <7a> after each "CurrentDemandRes" <7b>.

b) Wait until transition to  $I_{EVSE\_intended}$  is finished.

Step 3:

Measure  $V_{T8} = V_{EVSE\_SideB\_DC}$  and adjust  $U_{T4}$  with a slew rate of  $\leq 1$  V/s until

$$V_{EVSE\_SideB\_DC} = V_{EVSE\_intended\_1} \pm 10 \text{ V DC}$$

while:

$$V_{EVSE\_SideB\_DC} \geq V_{EVSE\_min}$$

and

$$V_{EVSE\_SideB\_DC} \leq V_{EVSE\_max}$$

according to the latest operating range of the EV supply equipment as communicated in "CurrentDemandRes" <7b>.

Step 4:

Measure  $V_{T8} = V_{EVSE\_SideB\_DC}$  and adjust  $U_{T4}$  with a slew rate of  $\leq 1$  V/s until

$$V_{EVSE\_SideB\_DC} = V_{EVSE\_intended\_2} \pm 10 \text{ V DC}$$

while:

$$V_{EVSE\_SideB\_DC} \geq V_{EVSE\_min}$$

and

$$V_{EVSE\_SideB\_DC} \leq V_{EVSE\_max}$$

according to the latest operating range of the EV supply equipment as communicated in "CurrentDemandRes" <7b>.

NOTE The ±10 V DC value mentioned in step 3 and step 4 has been chosen arbitrarily and is not related to the permissible accuracy of the side B voltage measurement of the EV supply equipment as specified in CC.6.3.

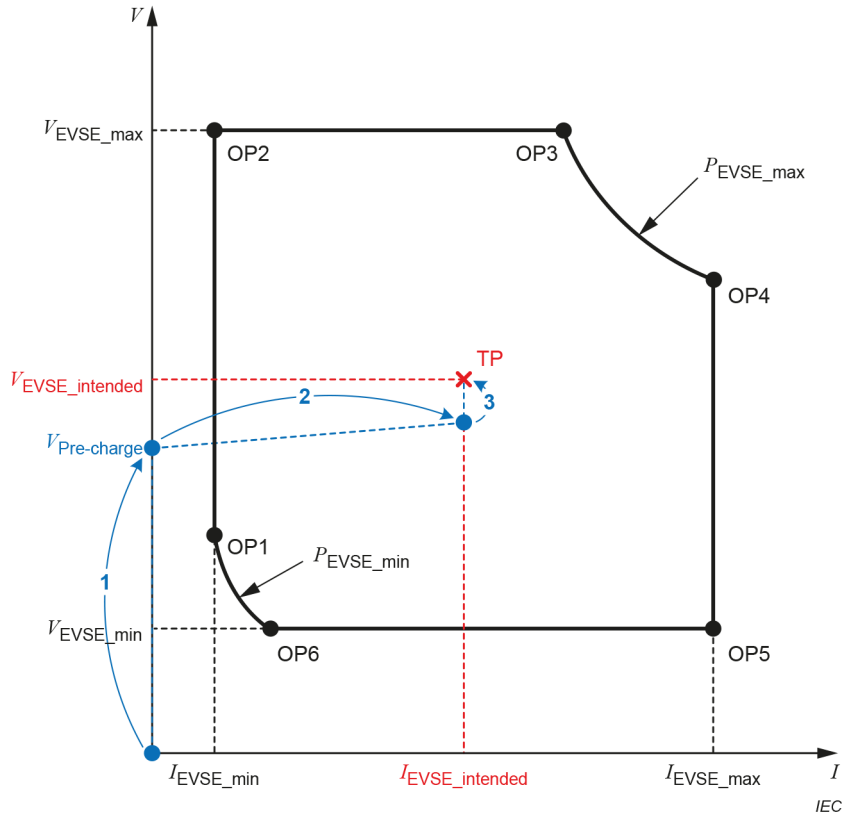

Figure CC.23 – Approaching a single test point TP in CCM (example 1)

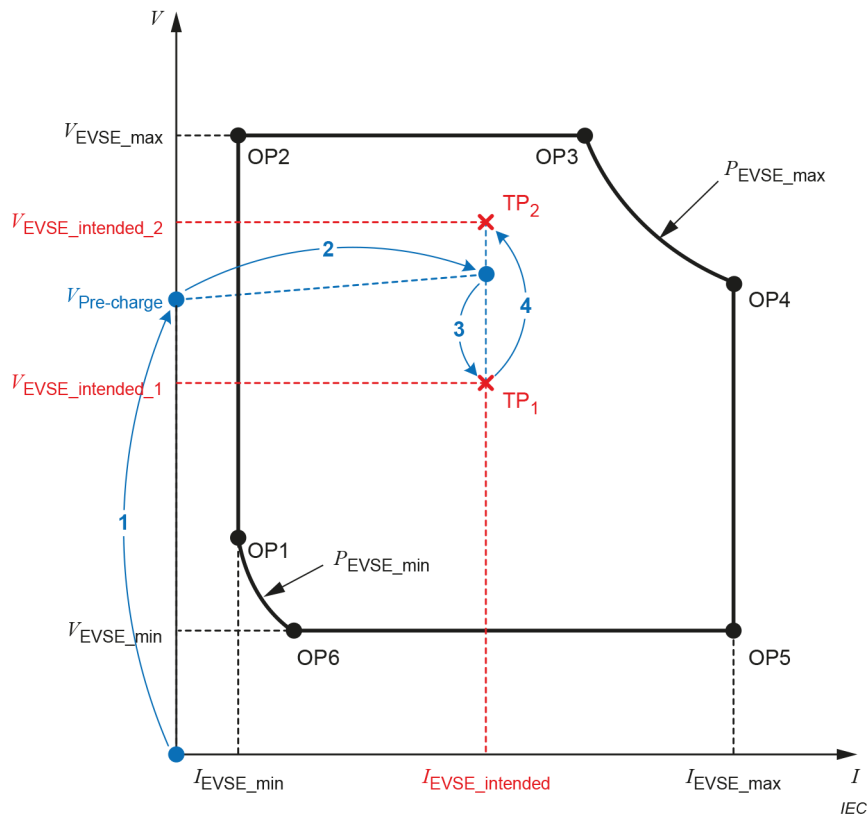

Figure CC.24 – Approaching multiple test points  $TP_n$  CCM (example 2)

## CC.7.5 Test cases

### CC.7.5.1 Compatibility check

#### CC.7.5.1.1 Reference requirements

This test case considers the following requirements:

- 6.3.1.104 Compatibility check;
- CC.3.2 Normal startup;
- CC.3.3 Normal shutdown;
- CC.5.6 Compatibility check.

#### CC.7.5.1.2 Description

Test if the EV supply equipment will not proceed with the communication session in case of:

$$V_{EVSE\_min} > V_{EV\_max}$$

#### CC.7.5.1.3 Test setup

Standard test setup.

#### CC.7.5.1.4 Preconditions

- For DIN SPEC 70121:2014: Message "ContractAuthenticationRes" was successfully received by the EV simulator.
- For ISO 15118-2:2014: Message "AuthorizationRes" was successfully received by the EV simulator.

**CC.7.5.1.5 Definitions and calculations**

None.

**CC.7.5.1.6 Actions**

For DIN SPEC 70121:2014 and ISO 15118-2:2014:

- 1) send message "ChargeParameterDiscoveryReq" <3a> containing the following parameter:  
EVMaximumVoltageLimit =  $\max(V_{EVSE\_min} - 10 \text{ V DC}, 0 \text{ V DC})$ ;
- 2) proceed with the digital communication according to each standard.

**CC.7.5.1.7 Expected results**

To consider the test as passed,

- the EV supply equipment shall not proceed with the next message via digital communication according to each standard,
- the EV supply equipment shall respond with message "ChargeParameterDiscoveryRes" <3b> with parameter "ResponseCode" = 'FAILED\_WrongChargeParameter', and
- $V_{T8} < 60 \text{ V DC}$ .

**CC.7.5.2 Normal startup****CC.7.5.2.1 Reference requirements**

This test case considers the following requirements:

- CC.3.2 Normal startup.

**CC.7.5.2.2 Description**

Check if the EV supply equipment performs a normal startup according to Table CC.8.

**CC.7.5.2.3 Test setup**

Standard test setup.

**CC.7.5.2.4 Preconditions**

None.

**CC.7.5.2.5 Definitions and calculations**

None.

Definition of intended test point (TP):

TP =  $(I_{EVSE\_intended} / V_{EVSE\_intended})$  with:

- $I_{EVSE\_intended} = I_{EVSE\_min} + 0,5 \times (I_{EVSE\_max} - I_{EVSE\_min})$ ;
- $V_{EVSE\_intended} = V_{EVSE\_min} + 0,5 \times (V_{EVSE\_max} - V_{EVSE\_min})$ .

**CC.7.5.2.6 Actions**

This test shall be performed with every digital communication protocol which the EV supply equipment supports.

- 1) Set  $U_{T4} = 0 \text{ V DC}$  and close  $S_{T19}$ .

- 2) Mate the vehicle connector.
  - a) Connect PP (to be able to measure the resistances in the proximity circuit)  
Measure  $R_{S3}$  (configuration EE, see Figure CC.1) and  $R_{S5}$  (configuration FF, see Figure CC.2), respectively.  
Check if expected results 1) are achieved.
  - b) Connect CP (CP change from state Ax to state Bx)
- 3) Establish the data-link as defined in IEC 61851-24.  
Check if expected results 2) are achieved.
- 4) Establish digital communication as defined in IEC 61851-24.
- 5) Send the message "ChargeParameterDiscoveryReq" <3a> with the following parameters (amongst others):
  - EVMaximumCurrentLimit =  $I_{EVSE\_max}$ ;
  - EVMaximumVoltageLimit =  $V_{EVSE\_max}$ .
 Check if expected results 3) are achieved.
- 6) Lock the vehicle connector without closing  $S_{V2}$  (CP remains in state B).  
Check if expected results 4) are achieved.
- 7) Close  $S_{V2}$  (CP change from state B to state C/D).
- 8) Send one or more "CableCheckReq" <4a> messages.  
Check if expected results 5) are achieved.
- 9) Send one or more "PreChargeReq" <5a> messages with following parameters:
  - EVTargetCurrent =  $I_{EV\_target} = 2 \text{ A}$ ;
  - EVTargetVoltage =  $V_{EV\_target} = V_{EVSE\_mid}$ .
 Set  $U_{T4} = V_{EVSE\_mid}$ .  
Check if expected results 6) are achieved.  
If the absolute voltage difference between  $V_{T11}$  of the test load and  $V_{T8}$  is < 20 V DC,  $S_{T17}$  and  $S_{T18}$  shall be closed (see t9).  
The EV simulator may adapt the target voltage of the EV with cyclic "PreChargeReq/Res" <5a>/<5b> messages to compensate for voltage deviation.
- 10) Send a message "PowerDeliveryReq" <6a> with parameter "ReadyToCharge" = 'True'.  
Check if expected results 7) are achieved.
- 11) Approach the test point TP according to CC.7.4 applying step 2 and step 3.  
Check if expected results 8) are achieved.

#### CC.7.5.2.7 Expected results

- 1) PP resistor  $R_{S3} = 150 \Omega (\pm 10 \%)$  (configuration EE, see Table CC.2).  
PP resistor  $R_{S5} = 1\,500 \Omega (\pm 3 \%)$  (configuration FF, see Table CC.4).
- 2) The EV supply equipment shall turn on its CP oscillator if the EV supply equipment is ready for energy transfer and if the CP oscillator is not already turned on.  
The EV supply equipment shall maintain a CP duty cycle of 5% unless a certain condition requires a different CP duty cycle (see t1).
- 3) The compatibility check is performed by the EV supply equipment.  
The EV supply equipment shall send message "ChargeParameterDiscoveryRes" <3b> with the following parameters:
  - EVSEMaximumVoltageLimit;

- EVSEMinimumVoltageLimit;
- EVSEMaximumCurrentLimit;
- EVSEMinimumCurrentLimit;

considering the compatibility check (see t2 ► t3).

Furthermore, the EV supply equipment shall send the EV the result of the compatibility check in message "ChargeParameterDiscoveryRes" <3b> with following parameters:

- ResponseCode = "OK";
  - EVSEProcessing = "Finished" (see t3).
- 4) The EV supply equipment shall not send the first "CableCheckRes" <4b> message and shall not apply a present voltage at side B > 60 V DC if the CP state is not C2 or D2 (see t4 ► t5).
  - 5) The EV supply equipment shall check if the CP state changed to state C/D before sending the first "CableCheckRes" <4b> message and before the present voltage at side B is > 60 V (see t4 ► t5).

The EV supply equipment shall check the functionality of the IMD and the insulation of side B. The EV supply equipment shall continuously report the insulation state with parameter "EVSEIsolationStatus" according to CC.4.1.4, "EVSEProcessing" = 'Ongoing', and "EVSEStatusCode" = 'EVSE\_IsolationMonitoringActive' in message "CableCheckRes" <4b> (see t4 ► t6).

The present voltage at side B  $V_{EVSE\_SideB\_DC}$  shall be according to the negotiated maximum voltage values communicated in the last set of ChargeParameterDiscoveryReq/Res messages according CC.4.1.2:

$$V_{EVSE\_Cable\_Check} = \min(V_{EV\_max\_CPD} + 50 \text{ V DC}, V_{EVSE\_max\_CPD}, 500 \text{ V DC}), \text{ if } V_{EV\_max\_CPD} \leq 500 \text{ V DC, or}$$

$$V_{EVSE\_Cable\_Check} = \min(1,1 \times V_{EV\_max\_CPD}, V_{EVSE\_max\_CPD}), \text{ if } V_{EV\_max\_CPD} > 500 \text{ V DC}$$

where

$V_{EV\_max\_CPD}$ : proposed negotiated maximum voltage at side B communicated by the EV in the last message "ChargeParameterDiscoveryReq" <3a>;

$V_{EVSE\_max\_CPD}$ : proposed negotiated maximum voltage at side B of the EV supply equipment communicated in the last ChargeParameterDiscoveryRes <3b>;

$V_{EVSE\_Cable\_Check}$ : present voltage at side B during the cable-check phase.

During the cable-check phase, the deviation of the  $V_{EVSE\_Cable\_Check}$  shall be less than  $\pm 5\%$  of the  $V_{EV\_max\_CPD}$  or less than  $\pm 2\%$  of the  $V_{EVSE\_max\_CPD}$ , whichever deviation is smaller.

After completing the cable-check phase, the EV supply equipment shall send message "CableCheckRes" <4b> with following parameters:

- EVSEIsolationStatus according to CC.4.1.4;
  - EVSEProcessing = "Finished";
  - EVSEStatusCode = "Ready", if the insulation status is 'Valid' and there are no errors (see t6).
- 6) The EV supply equipment adapts the present voltage at side B to the target voltage of the EV in the "PreChargeReq" <5a> message and sends the corresponding "PreChargeRes" <5b> message. During the pre-charge phase the EV supply equipment is able to supply a present current at side B as defined in CC.5.1, limit the present current at side B to 2 A DC and ignore the target current of the EV (see t7 ► t8).

The present voltage at side B of the EV supply equipment reaches the target voltage of the EV between the tolerances given in section 101.1.2.

- 7) After disabling the pre-charge current limitation (for example, pre-charge circuit, if any), and switching on its PECs, the EV supply equipment shall send message PowerDeliveryRes <6b> with parameter "EVSEStatusCode"= 'EVSE\_Ready' to indicate that it is ready for energy transfer and overvoltage protection (see t9 ► t11).
- 8) The EV supply equipment shall continuously monitor the insulation of side B and update parameter "EVSEIsolationStatus" in the next communicated messages that contain this parameter (see t11 ►).

The EV supply equipment shall adapt the present current at side B to the target current of the EV in message "CurrentDemandReq" <7a>.

The EV supply equipment shall respond with the following information to the EV in message CurrentDemandRes<7b>:

- its present current and voltage at side B;
- its applicable maximum/minimum current and voltage at side B;
- its present status (see t11 ► t12).

## **CC.7.6 Wake up of EV supply equipment by EV**

### **CC.7.6.1 Reference requirements**

This test case considers the following requirements:

- CC.5.2 Sleep mode and communication session restart methods.

#### **CC.7.6.1.1 Description**

Reaction on wake up action performed by EV after the EV supply equipment entered sleep mode.

#### **CC.7.6.1.2 Test setup**

Standard test setup.

#### **CC.7.6.1.3 Preconditions**

None.

#### **CC.7.6.1.4 Definitions and calculations**

Definition of intended test point:

TP = ( $I_{EVSE\_intended} / V_{EVSE\_intended}$ ) with:

- $I_{EVSE\_intended} = I_{EVSE\_min}$
- $V_{EVSE\_intended} = P_{EVSE\_min} / I_{EVSE\_min}$

TP equals to OP1.

#### **CC.7.6.1.5 Actions**

- 1) Approach test point TP according to CC.7.4.
- 2) Send message "PowerDeliveryReq" according to IEC 61851-24 with the parameter "ChargeProgress" = 'Stop'.
- 3) Wait for the "PowerDeliveryRes" message.
- 4) Send message "SessionStopReq" according to IEC 61851-24 with the parameter "ChargingSession" = 'Pause'.
- 5) Wait for "SessionStopRes".
- 6) Pause the data-link (D-LINK\_PAUSE.request()).

- 7) Wait until the EV supply equipment enters sleep mode, which is indicated by a disabled CP oscillator, that is, change from CP state B2 to B1.
- 8) Perform one B1-C1-B1 toggle according to IEC 61851-1:2017, Table A.6, Sequence 11.

#### **CC.7.6.1.6 Expected results**

The EV supply equipment signals a wake up by enabling the CP oscillator with a duty cycle of 5 %, that is, change from CP state B1 to B2.

#### **CC.7.6.2 Loss of electrical continuity of the control pilot conductor**

##### **CC.7.6.2.1 Reference requirements**

This test case considers the following requirements:

- 6.3.1.105 De-energization of the power supply to the EV;
- 6.3.1.113.4 Emergency shutdown;
- CC.4.3 Loss of electrical continuity of the control pilot conductor.

##### **CC.7.6.2.2 Description**

EV supply equipment emergency shutdown in case of losing the electrical continuity of the control pilot conductor (CP change from state C to states A or B).

##### **CC.7.6.2.3 Test setup**

Standard test setup.

##### **CC.7.6.2.4 Preconditions**

Based on the data sheet of the EV supply equipment, the EV simulator shall communicate the following properties with the message "ChargeParameterDiscoveryReq" <3a>:

- $V_{EV\_max} = 1,2 \times V_{EVSE\_max}$ ;
- $V_{EV\_min} = 0,8 \times V_{EVSE\_min}$ ;
- $I_{EV\_max} = 1,2 \times I_{EVSE\_max}$ ;
- $I_{EV\_min} = 0,8 \times I_{EVSE\_min}$ ;
- $P_{EV\_max} = 1,2 \times P_{EVSE\_max}$ .

The EV supply equipment shall have successfully communicated the following properties to the EV simulator with the message "ChargeParameterDiscoveryRes" <3b>:

- $V_{EVSE\_min}$ ;
- $V_{EVSE\_max}$ ;
- $I_{EVSE\_min}$ ;
- $I_{EVSE\_max}$ ;
- $P_{EVSE\_max}$ .

##### **CC.7.6.2.5 Definitions and calculations**

Definition of intended test points:

TP<sub>1</sub> = ( $I_{EVSE\_intended\_1}$  /  $V_{EVSE\_intended\_1}$ ) with:

- $I_{EVSE\_intended\_1} = I_{EVSE\_max}$

- $V_{EVSE\_intended\_1} = P_{EVSE\_max} / I_{EVSE\_max}$
- TP<sub>1</sub> equals to OP4.

TP<sub>2</sub> = ( $I_{EVSE\_intended\_2} / V_{EVSE\_intended\_2}$ ) with:

- $I_{EVSE\_intended\_2} = P_{EVSE\_max} / V_{EVSE\_max}$
- $V_{EVSE\_intended\_2} = V_{EVSE\_max}$
- TP<sub>2</sub> equals to OP3.

TP<sub>3</sub> = ( $I_{EVSE\_intended\_3} / V_{EVSE\_intended\_3}$ ) with:

- $I_{EVSE\_intended\_3} = 0$  A DC
- $V_{EVSE\_intended\_3} = V_{EVSE\_min} + 1/2 \times (V_{EVSE\_max} - V_{EVSE\_min})$

Further definitions:

- $V_{EVSE\_mid} = V_{EVSE\_min} + 1/2 \times (V_{EVSE\_max} - V_{EVSE\_min})$

#### CC.7.6.2.6 Actions

Each of the following cases shall be tested.

- 1) CP change from state C to state A during the cable-check phase
  - The normal startup sequence shall be successfully done until  $t = t_4$  according to Figure CC.5.
  - Open S<sub>T3</sub> and check expected results.
- 2) CP change from state C to state A during the pre-charge phase
  - Approach test point TP3 according to CC.7.4.
  - Open S<sub>T3</sub> and check expected results.
- 3) CP change from state C to state A during the energy transfer stage at TP<sub>1</sub>
  - Approach test point TP1 according to CC.7.4.
  - Open S<sub>T3</sub> and check expected results.
- 4) CP change from state C to state A during the energy transfer stage at TP<sub>2</sub>
  - Approach test point TP2 according to CC.7.4.
  - Open S<sub>T3</sub> and check expected results.
- 5) CP change from state C to state B during the energy transfer stage at TP<sub>1</sub>: see 3)
  - Open S<sub>V2</sub> in the EV simulator and check expected results.
- 6) CP change from state C to state B during the energy transfer stage at TP<sub>2</sub>: see 4)
  - Open S<sub>V2</sub> in the EV simulator and check expected results.

NOTE 1 The test cases 1), 2), 3), 4), 5) and 6) can be done in arbitrary order, and fault states need to be cleared between tests.

NOTE 2 If TP<sub>1</sub> = TP<sub>2</sub> one joint test run is sufficient.

#### CC.7.6.2.7 Expected results

The EV supply equipment shall perform an emergency shutdown. That means that the EV supply equipment shall:

- turn off its CP oscillator to indicate an emergency shutdown in 20 ms or less after opening S<sub>T3</sub> or S<sub>V2</sub>,

- reduce  $A_{T1}$  to  $\leq 5$  A DC and disable side B in 30 ms or less after opening  $S_{T3}$  or  $S_{V2}$ ,
- reduce  $V_{T8}$  to  $\leq 60$  V DC in 1 010 ms or less after opening  $S_{T3}$  or  $S_{V2}$ , and
- reduce  $V_{T6}$  and  $V_{T7}$  to  $\leq 60$  V DC in 1 010 ms or less after opening  $S_{T3}$  or  $S_{V2}$ .

In addition, for CC.7.6.2.6 5) and 6):

- The CP oscillator shall be switched off (CP change from state B2 to state X1) in 20 ms or less.

### **CC.7.6.3 Protective conductor continuity checking**

#### **CC.7.6.3.1 Reference requirements**

This test case considers the following requirements:

- 6.3.1.2 Continuous continuity checking of the protective conductor;
- 6.3.1.113.4 Emergency Shutdown;
- CC.4.7 Loss of electrical continuity of the protective conductor.

#### **CC.7.6.3.2 Description**

Emergency shutdown in case of loss of protective conductor continuity. This test case applies to EV supply equipment with a rated maximum voltage of the EV supply equipment at side B  $\geq 60$  V DC.

#### **CC.7.6.3.3 Test setup**

Standard test setup with switch  $S_{T28}$  to break the protective conductor continuity in the EV supply equipment side.

This test requires the EV supply equipment to be modified as shown in the test setup.

#### **CC.7.6.3.4 Preconditions**

None.

#### **CC.7.6.3.5 Definitions and calculations**

Definition of intended test points:

$TP_1 = (I_{EVSE\_intended\_1} / V_{EVSE\_intended\_1})$  with:

- $I_{EVSE\_intended\_1} = P_{EVSE\_max} / V_{EVSE\_max}$
- $V_{EVSE\_intended\_1} = V_{EVSE\_max}$
- $TP_1$  corresponds to OP3 according to Figure CC.22.

$TP_2 = (I_{EVSE\_intended\_2} / V_{EVSE\_intended\_2})$  with:

- $I_{EVSE\_intended\_2} = I_{EVSE\_max}$
- $V_{EVSE\_intended\_2} = P_{EVSE\_max} / I_{EVSE\_max}$
- $TP_2$  corresponds to OP4 according to Figure CC.22.

**CC.7.6.3.6 Actions**

Repeat the following steps for each of the defined test points.

- 1) Approach the test point TP according to CC.7.4.
- 2) Open S<sub>T28</sub>.
- 3)  $t_{CP\_open}$  is the point in time when S<sub>T28</sub> changes its state from closed to opened (to be derived from the transition in V<sub>T1</sub>)
- 4) Check if the expected results are achieved.

**CC.7.6.3.7 Expected results**

The EV supply equipment shall perform an emergency shutdown. That means that the EV supply equipment shall

- turn off its CP oscillator to indicate an emergency shutdown in 160 ms or less after  $t_{CP\_open}$ ,
- reduce its present current at side B to  $\leq 5$  A DC and disable its side B in 170 ms or less after  $t_{CP\_open}$ ,
- reduce the present voltage at side B between DC+ and DC– to  $\leq 60$  V DC in 1 150 ms or less after  $t_{CP\_open}$ , and
- reduce the present voltage at side B between DC+ and protective conductor, and between DC– and protective conductor to  $\leq 60$  V DC in 1 150 ms or less after  $t_{CP\_open}$ .

**CC.7.6.4 Rated EV supply equipment values at side B****CC.7.6.4.1 General**

The test points TP<sub>n</sub> for the test is shown in Figure CC.25.

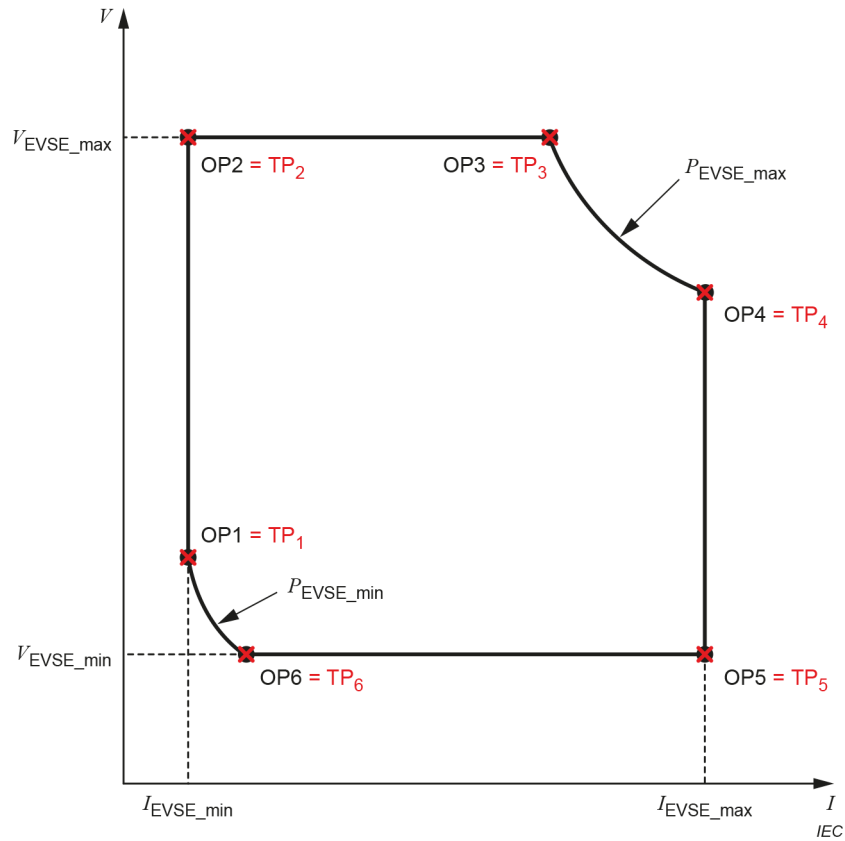

**Figure CC.25 – Test points  $TP_n$**

#### **CC.7.6.4.2 Reference requirements**

This test setup considers the following requirements:

- 101.1.1 Operating ranges for voltage, current, and power at side B;
- 101.1.2.1 Side B current regulation in CCM;
- 101.1.5 Periodic and random deviation (current ripple in CCM);
- CC.5.5.7 The target current of the EV is less than the applicable minimum current of the EV supply equipment at side B;
- CC.5.5.8 The target current of the EV is more than the applicable maximum current of the EV supply equipment at side B;
- CC.5.5.9 The target voltage of the EV is less than the present voltage at side B;
- CC.5.5.10 The target voltage of the EV is more than the maximum voltage limits;
- CC.5.5.13 Limitations due to the applicable minimum power of the EV supply equipment at side B;
- CC.5.5.14 Limitations due to the applicable maximum power of the EV supply equipment at side B;
- CC.6.2 Side B current regulation.

**CC.7.6.4.3 Description**

Part A:

Test if the EV supply equipment is able to deliver present voltage at side B in the voltage range  $[V_{EVSE\_min}, V_{EVSE\_max}]$  and the target current of the EV in the current range  $[I_{EVSE\_min}, I_{EVSE\_max}]$  in CCM less than or equal to the limit of the rated maximum power of the EV supply equipment at side B  $[P_{EVSE\_max}]$  at the ambient temperature  $-5\text{ °C}$  to  $+40\text{ °C}$  and  $\geq 2\ 000\text{ m}$  above sea level.

Part B:

Test if the EV supply equipment delivers the expected current and voltage at side B if the target current or voltage of the EV values are outside the operating range of the EV supply equipment.

**CC.7.6.4.4 Test setup**

Standard test setup.

**CC.7.6.4.5 Preconditions**

None.

**CC.7.6.4.6 Definitions and calculations**

In this test case, certain properties of the EV supply equipment are tested at specific test points  $TP_n$  at the edges of the operating range of the EV supply equipment, with specific combinations of target current and voltage of the EV.

In this test case, certain properties of the EV supply equipment are tested at specific test points TP at the edges of the operating range of the EV supply equipment.

Definition of test points TP:

$TP_1 = (I_{EVSE\_intended\_1} / V_{EVSE\_intended\_1})$  with:

- $I_{EVSE\_intended\_1} = I_{EVSE\_min}$
- $V_{EVSE\_intended\_1} = P_{EVSE\_min} / I_{EVSE\_min}$
- $TP_1$  corresponds to OP1.

$TP_2 = (I_{EVSE\_intended\_2} / V_{EVSE\_intended\_2})$  with:

- $I_{EVSE\_intended\_2} = I_{EVSE\_min}$
- $V_{EVSE\_intended\_2} = V_{EVSE\_max}$
- $TP_2$  corresponds to OP2.

$TP_3 = (I_{EVSE\_intended\_3} / V_{EVSE\_intended\_3})$  with:

- $I_{EVSE\_intended\_3} = P_{EVSE\_max} / V_{EVSE\_max}$
- $V_{EVSE\_intended\_2} = V_{EVSE\_max}$
- $TP_3$  corresponds to OP3.

TP<sub>4</sub> = ( $I_{EVSE\_intended\_4}$  /  $V_{EVSE\_intended\_4}$ ) with:

- $I_{EVSE\_intended\_4} = I_{EVSE\_max}$
- $V_{EVSE\_intended\_4} = P_{EVSE\_max} / I_{EVSE\_max}$
- TP<sub>4</sub> corresponds to OP4.

TP<sub>5</sub> = ( $I_{EVSE\_intended\_5}$  /  $V_{EVSE\_intended\_5}$ ) with:

- $I_{EVSE\_intended\_5} = I_{EVSE\_max}$
- $V_{EVSE\_intended\_5} = V_{EVSE\_min}$
- TP<sub>5</sub> corresponds to OP5.

TP<sub>6</sub> = ( $I_{EVSE\_intended\_6}$  /  $V_{EVSE\_intended\_6}$ ) with:

- $I_{EVSE\_intended\_6} = P_{EVSE\_min} / V_{EVSE\_min}$
- $V_{EVSE\_intended\_6} = V_{EVSE\_min}$
- TP<sub>6</sub> corresponds to OP6.

Calculations done continuously during the measurement duration of each TP<sub>*n*</sub>:

- Determine the absolute present current at side B deviation:  
 $I_{dev\_abs} = |I_{EVSE\_SideB\_DC} - I_{EV\_target}|$  for  $I_{EV\_target} \leq 50$  A DC
- Determine the relative present current at side B deviation:  
 $I_{dev\_rel} = |I_{EVSE\_SideB\_DC} - I_{EV\_target}| / I_{EV\_target}$  for  $I_{EV\_target} > 50$  A DC
- Determine the present power at side B:  
 $P_{EVSE\_SideB\_DC} = V_{EVSE\_SideB\_DC} \times I_{EVSE\_SideB\_DC}$

#### CC.7.6.4.7 Actions

The EV simulator shall cyclically send "CurrentDemandReq" <7a> messages with a cycle time of 1 s or less in order to enable the EV supply equipment to communicate its (potentially updated) applicable maximum and minimum values in "CurrentDemandRes" <7b>.

General description of test case and specification of parameter values:

The sequence of the test points can be optimized for the test load. Delay times between the communication sessions can be used for example, for cooling down the test load.

The test of each test point consists of two main parts a) and b) as follows:

- a) test of the side B of the EV supply equipment in CCM at test points located at the boundary of the operating range;
- b) test of the reaction of the EV supply equipment on a target values outside the operating range in CCM .

Actions for Part A)

- 1) Approach a test point according to CC.7.4.
- 2) Measure  $I_{EVSE\_SideB\_DC}$ ,  $I_{rip\_low}$ ,  $I_{rip\_mid}$  and  $I_{rip\_high}$ .
- 3) Receive  $I_{EVSE\_measure}$  and  $V_{EVSE\_measure}$ .
- 4) Perform calculations to be done for each test point TP<sub>*n*</sub>.
- 5) Check if expected results for part a) are achieved.

Actions for Part B)

- 6) After a test point has been successfully approached as described in part a), the EV simulator shall send "CurrentDemandReq" <7a> messages after each "CurrentDemandRes" <7b> message, with the parameter values shown in Table CC.21 that are outside the operating range of the EV supply equipment.

**Table CC.21 – EV simulator target current and voltage**

Test point	EVTargetCurrent = $I_{EV\_target}$	EVTargetVoltage = $V_{EV\_target}$ (to allow for CCM)
TP <sub>1</sub>	$0,8 \times I_{EVSE\_intended}$	$1,2 \times V_{EVSE\_max}$
TP <sub>2</sub>	$0,8 \times I_{EVSE\_intended}$	$1,2 \times V_{EVSE\_max}$
TP <sub>3</sub>	$1,2 \times I_{EVSE\_intended}$	$1,2 \times V_{EVSE\_max}$
TP <sub>4</sub>	$1,2 \times I_{EVSE\_intended}$	$1,2 \times V_{EVSE\_max}$
TP <sub>5</sub>	$1,2 \times I_{EVSE\_intended}$	$1,2 \times V_{EVSE\_max}$
TP <sub>6</sub>	$0,8 \times I_{EVSE\_intended}$	$1,2 \times V_{EVSE\_max}$

- 7) Request a target current of the EV outside the operating range of the EV supply equipment by sending "CurrentDemandReq" <7a> messages with the new parameter values specified in Table CC.21.
- 8) Check if expected results for part b) are achieved.

#### CC.7.6.4.8 Expected results

Part A:

For  $I_{EVSE\_target\_n} \leq 5$  A DC:

- $I_{dev\_abs\_n} \leq 150$  mA DC.

For  $5$  A <  $I_{EVSE\_target\_n} \leq 50$  A DC:

- $I_{dev\_abs\_n} \leq 1,5$  A DC.

For  $I_{EVSE\_target\_n} > 50$  A DC:

- $I_{dev\_rel\_n} \leq 3$  %.

The current ripple shall meet the limits in Table CC.22.

**Table CC.22 – Current ripple limits**

	Current ripple, $A_{peak-to-peak}$		
	$I_{EVSE\_SideB\_DC} \leq 200$ A DC	200 A DC < $I_{EVSE\_SideB\_DC} \leq 400$ A DC	$I_{EVSE\_SideB\_DC} > 400$ A DC
$I_{rip\_low}$	$\leq 1,5$	$\leq (I_{EVSE\_SideB\_DC} \times 0,75 \%)$	$\leq (I_{EVSE\_SideB\_DC} \times 0,75 \%)$
$I_{rip\_mid}$	$\leq 6,0$	$\leq 6,0$	$\leq (I_{EVSE\_SideB\_DC} \times 1,5 \%)$
$I_{rip\_high}$	$\leq 9,0$	$\leq (I_{EVSE\_SideB\_DC} \times 4,5 \%)$	$\leq (I_{EVSE\_SideB\_DC} \times 4,5 \%)$

Part B:

For TP<sub>1</sub>, TP<sub>2</sub> and TP<sub>6</sub>:

- $I_{EVSE\_SideB\_DC} = 0 \text{ A DC} \pm 0,150 \text{ A DC}$ .
- The expected results for the current ripple as specified in part a) shall apply.

For TP<sub>3</sub>, TP<sub>4</sub> and TP<sub>5</sub>:

- The present current and voltage at side B shall not change after requesting parameters EVTargetCurrent and EVTargetVoltage according to Table CC.21 in the "CurrentDemandReq" <3a> messages.
- The expected results as specified in part a) shall apply.

### **CC.7.6.5 Protection against overvoltage at the vehicle connector**

#### **CC.7.6.5.1 Emergency shutdown caused by an overvoltage (test 1)**

##### **CC.7.6.5.1.1 Reference requirements**

This test case considers the following requirements:

- 6.3.1.106.2 Protection against overvoltage between DC+ and DC– at the vehicle connector by emergency shutdown;
- 6.3.1.113.4 Emergency shutdown.

##### **CC.7.6.5.1.2 Description**

Emergency shutdown in case the present voltage at side B is more than the thresholds in Table 103. The EV simulator switches a voltage source, and the present voltage at side B becomes more than the voltage threshold for emergency shutdown.

##### **CC.7.6.5.1.3 Test setup**

Standard test setup.

##### **CC.7.6.5.1.4 Preconditions**

None.

##### **CC.7.6.5.1.5 Definitions and calculations**

Definition of times:

$t_{\text{overvoltage}}$  is the point in time when the overvoltage condition starts

Definition of intended test points:

TP<sub>1</sub> = ( $I_{EVSE\_intended\_1}$  /  $V_{EVSE\_intended\_1}$ ) with:

- $I_{EVSE\_intended\_1} = I_{EVSE\_min} + 0,5 \times (I_{EVSE\_max} - I_{EVSE\_min})$
- $V_{EVSE\_intended\_1} = \min(V_{EVSE\_max}; 500 \text{ V}) - 50 \text{ V}$
- TP<sub>1</sub> is always applicable.

$TP_2 = (I_{EVSE\_intended\_2} / V_{EVSE\_intended\_2})$  with:

- $I_{EVSE\_intended\_2} = I_{EVSE\_intended\_1}$
- $V_{EVSE\_intended\_2} = \min(V_{EVSE\_max}; 750 \text{ V}) - 50 \text{ V}$
- $TP_2$  is only applicable if  $V_{EVSE\_max} > 500 \text{ V}$ .

$TP_3 = (I_{EVSE\_intended\_3} / V_{EVSE\_intended\_3})$  with:

- $I_{EVSE\_intended\_3} = I_{EVSE\_intended\_1}$
- $V_{EVSE\_intended\_3} = \min(V_{EVSE\_max}; 850 \text{ V}) - 50 \text{ V}$
- $TP_3$  is only applicable if  $V_{EVSE\_max} > 750 \text{ V}$ .

$TP_4 = (I_{EVSE\_intended\_4} / V_{EVSE\_intended\_4})$  with:

- $I_{EVSE\_intended\_4} = I_{EVSE\_intended\_1}$
- $V_{EVSE\_intended\_4} = \min(V_{EVSE\_max}; 1\,000 \text{ V}) - 50 \text{ V}$
- $TP_4$  is only applicable if  $V_{EVSE\_max} > 850 \text{ V}$ .

Target values requested to approach test point TP:

- $I_{EV\_target\_m} = I_{EVSE\_intended\_m}$

#### CC.7.6.5.1.6 Actions

- 1) Approach the test point  $TP_1$  according to CC.7.4 with  $V_{EV\_target\ 1} = \min(V_{EVSE\_max}; 500 \text{ V})$  starting from Step 2 of the exemplary approach.
- 2) Increase  $U_{T4}$  so that  $V_{T8}$  increases in 20 ms or less to  $V_{T8} = 550 \text{ V} + 15 \text{ V}$ .
- 3)  $t_{\text{overvoltage}}$  is the point in time once  $V_{T8} \geq 550 \text{ V}$ .
- 4) Check if expected results are achieved.
- 5) Depending on the applicability of  $TP_2$ ,  $TP_3$  and  $TP_4$ , repeat the test steps using:

$TP_2$ :

- $V_{EV\_target\ 2} = V_{EV\_max\ 2} = \min(V_{EVSE\_max}; 750 \text{ V})$
- $V_{T8} = 825 \text{ V} + 15 \text{ V}$
- $t_{\text{overvoltage}}$  is the point in time once  $V_{T8} \geq 825 \text{ V}$

$TP_3$ :

- $V_{EV\_target\ 3} = V_{EV\_max\ 3} = \min(V_{EVSE\_max}; 850 \text{ V})$
- $V_{T8} = 935 \text{ V} + 15 \text{ V}$
- $t_{\text{overvoltage}}$  is the point in time once  $V_{T8} \geq 935 \text{ V}$

$TP_4$ :

- $V_{EV\_target\ 4} = V_{EV\_max\ 4} = \min(V_{EVSE\_max}; 1\,000 \text{ V})$
- $V_{T8} = 1\,100 \text{ V} + 15 \text{ V}$
- $t_{\text{overvoltage}}$  is the point in time once  $V_{T8} \geq 1\,100 \text{ V}$

### CC.7.6.5.1.7 Expected results

The EV supply equipment shall perform an emergency shutdown. That means that the EV supply equipment shall

- turn off its CP oscillator to indicate an emergency shutdown in 20 ms or less after  $t_{\text{overvoltage}}$ ,
- reduce its present current at side B to  $\leq 5$  A DC and disable its side B in 30 ms or less after  $t_{\text{overvoltage}}$ ,
- reduce the present voltage at side B to  $\leq 60$  V DC between DC+ and DC– in 1 010 ms or less after  $t_{\text{overvoltage}}$ , and
- reduce the present voltage at side B to  $\leq 60$  V DC between DC+ and the protective conductor, and between DC– and the protective conductor in 1 010 ms or less after  $t_{\text{overvoltage}}$ .

### CC.7.6.5.2 Error shutdown caused by an overvoltage (test 2)

#### CC.7.6.5.2.1 Reference requirements

This test case considers the following requirements:

- 6.3.1.106.3 Protection against overvoltage between DC+ and DC– at the vehicle connector by error shutdown;
- 6.3.1.113.3 Error shutdown.

#### CC.7.6.5.2.2 Description

Error shutdown in case of an overvoltage at the vehicle connector not caused by the EV supply equipment.

The EV simulator switches a voltage source and the present voltage at side B becomes more than the negotiated maximum voltage.

#### CC.7.6.5.2.3 Test setup

Standard test setup.

#### CC.7.6.5.2.4 Preconditions

None.

#### CC.7.6.5.2.5 Definitions and calculations

Definition of times:

- $t_{\text{overvoltage}}$  is the point in time when the overvoltage condition starts

Definition of intended test point:

TP = ( $I_{\text{EVSE\_intended}}$  /  $V_{\text{EVSE\_intended}}$ ) with:

- $I_{\text{EVSE\_intended}} = I_{\text{EVSE\_min}} + 0,5 \times (I_{\text{EVSE\_max}} - I_{\text{EVSE\_min}})$
- $V_{\text{EVSE\_intended}} = V_{\text{EVSE\_max}} - 50$  V

Target values requested to approach test point TP:

- $I_{EV\_target} = I_{EVSE\_intended}$
- $V_{EV\_target} = V_{EVSE\_max}$
- $V_{EV\_max} = V_{EVSE\_max} - 25\text{ V}$

#### **CC.7.6.5.2.6 Actions**

- 1) Approach the test point TP according to CC.7.4.
- 2) Increase  $U_{T4}$  so that  $V_{T8}$  increases in 20 ms or less to  $V_{T8} = V_{EV\_max} + 15\text{ V}$ .
- 3)  $t_{\text{overvoltage}}$  is the point in time once  $V_{T8} \geq V_{EV\_max}$ .
- 4) Check if expected results are achieved.

#### **CC.7.6.5.2.7 Expected results**

The EV supply equipment shall perform an error shutdown. That means that the EV supply equipment shall

- reduce its present current at side B to  $\leq 5\text{ A}$  and disable its side B in 1 450 ms or less after  $t_{\text{overvoltage}}$ ,
- reduce the present voltage at side B to  $\leq 60\text{ V}$  between DC+ and DC– in 2 950 ms or less after  $t_{\text{overvoltage}}$ , and
- reduce the present voltage at side B to  $\leq 60\text{ V}$  between DC+ and the protective conductor, and between DC– and the protective conductor in 2 950 ms or less after  $t_{\text{overvoltage}}$ .

#### **CC.7.6.5.3 Temporary overvoltage (test 3)**

##### **CC.7.6.5.3.1 Reference requirements**

This test case considers the following requirements:

- 6.3.1.106.3 Protection against overvoltage between DC+ and DC– at the vehicle connector by error shutdown.
- 6.3.1.113.3 Error shutdown.

##### **CC.7.6.5.3.2 Description**

Robustness demonstration in case of a temporary overvoltage which is not caused by the EV supply equipment.

##### **CC.7.6.5.3.3 Test setup**

Standard test setup.

##### **CC.7.6.5.3.4 Preconditions**

None.

##### **CC.7.6.5.3.5 Definitions and calculations**

Definition of times:

- $t_{\text{overvoltage}}$  is the point in time when the overvoltage condition starts.

Definition of intended test point:

TP = ( $I_{EVSE\_intended}$  /  $V_{EVSE\_intended}$ ) with:

- $I_{EVSE\_intended} = I_{EVSE\_min} + 0,5 \times (I_{EVSE\_max} - I_{EVSE\_min})$
- $V_{EVSE\_intended} = V_{EVSE\_max} - 50 \text{ V}$

Target values requested to approach test point TP:

- $I_{EV\_target} = I_{EVSE\_intended}$
- $V_{EV\_target} = V_{EVSE\_max}$
- $V_{EV\_max} = V_{EVSE\_max} - 25 \text{ V}$

**CC.7.6.5.3.6 Actions**

- 1) Approach the test point TP according to CC.7.4.
- 2) Modulate  $U_{T4}$  so that  $V_{T8}$  fulfils the following criteria in chronological order:
  - a)  $V_{T8}$  increases from ( $V_{EVSE\_max} - 50 \text{ V}$ ) to ( $V_{EV\_max} + 15 \text{ V}$ ) in 20 ms or less;
  - b)  $V_{T8}$  stays on the increased level so that ( $V_{T8} \geq V_{EV\_max}$ ) for  $190 \text{ ms} \pm 10 \text{ ms}$ ;
  - c)  $V_{T8}$  decreases back to ( $V_{T8} - 50 \text{ V}$ ) in 20 ms or less.

See Figure CC.26 for the voltage profile to be achieved.

- 3)  $t_{\text{overvoltage}}$  is the point in time once  $V_{T8} \geq V_{EV\_max}$ .
- 4) Check if expected results are achieved.

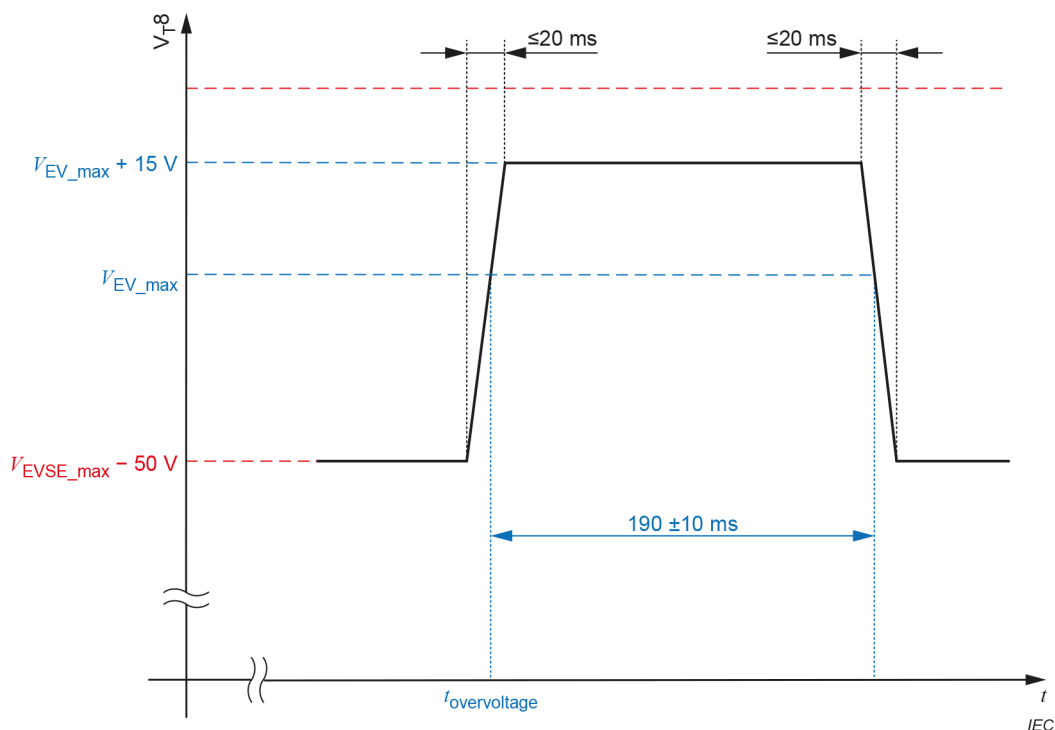

**Figure CC.26 – Voltage at the vehicle connector**

**CC.7.6.5.3.7 Expected results**

The EV supply equipment shall remain in the energy transfer stage and not perform an error shutdown during the temporary overvoltage condition.

#### CC.7.6.5.4 Error shutdown caused by an overvoltage (test 4)

##### CC.7.6.5.4.1 Reference requirements

This test case considers the following requirements:

- 6.3.1.106.3 Protection against overvoltage between DC+ and DC– at the vehicle connector by error shutdown.
- 6.3.1.113.3 Error shutdown.

##### CC.7.6.5.4.2 Description

Error shutdown in case of an overvoltage which is not caused by the EV supply equipment.

The EV simulator modifies its maximum voltage limit sent to the EV supply equipment to a value less than the present voltage at side B.

##### CC.7.6.5.4.3 Test setup

Standard test setup.

##### CC.7.6.5.4.4 Preconditions

None.

##### CC.7.6.5.4.5 Definitions and calculations

Definition of times:

- $t_{\text{overvoltage}}$  is the point in time when the overvoltage condition starts.

Definition of intended test point:

TP = ( $I_{\text{EVSE\_intended}}$  /  $V_{\text{EVSE\_intended}}$ ) with:

- $I_{\text{EVSE\_intended}} = I_{\text{EVSE\_min}} + 0,5 \times (I_{\text{EVSE\_max}} - I_{\text{EVSE\_min}})$ ;
- $V_{\text{EVSE\_intended}} = V_{\text{EVSE\_max}} - 50 \text{ V}$ .

Target values requested to approach test point TP:

- $I_{\text{EV\_target}} = I_{\text{EVSE\_intended}}$ ;
- $V_{\text{EV\_target}} = V_{\text{EVSE\_max}} - 25 \text{ V}$ ;
- $V_{\text{EV\_max}} = V_{\text{EV\_target}}$ .

##### CC.7.6.5.4.6 Actions

- 1) Approach the test point TP according to CC.7.4.
- 2) Send "CurrentDemandReq" message with  $V_{\text{EV\_max}} = V_{\text{EVSE\_intended}} - 15 \text{ V}$ .
- 3)  $t_{\text{overvoltage}}$  is the point in time when the message "CurrentDemandReq" is sent.
- 4) Check if expected results are achieved.

##### CC.7.6.5.4.7 Expected results

The EV supply equipment shall perform an error shutdown. That means that the EV supply equipment shall

- reduce its present current at side B to  $\leq 5 \text{ A}$  and disable its side B in 1 450 ms or less after  $t_{\text{overvoltage}}$ .

- reduce the present voltage at side B to  $\leq 60$  V between DC+ and DC– in 2 950 ms or less after  $t_{\text{overvoltage}}$ , and
- reduce the present voltage at side B to  $\leq 60$  V between DC+ and the protective conductor, and between DC– and the protective conductor in 2 950 ms or less after  $t_{\text{overvoltage}}$ .

### **CC.7.6.6 Emergency shutdown in case of proximity pilot disconnection**

#### **CC.7.6.6.1 Reference requirements**

This test case considers the following requirements:

- CC.4.4 Loss of electrical continuity of the proximity detection conductor.
- 6.3.1.113.4 Emergency shutdown.

#### **CC.7.6.6.2 Description**

Emergency shutdown in case of proximity pilot disconnection. The test applies to EV supply equipment of system C with a vehicle connector of configuration EE only. See Figure CC.1.

#### **CC.7.6.6.3 Test setup**

Standard test setup, with  $R_{T1} = R_V1$  and  $X_{T1} = X_V1$ . See Table CC.2.

#### **CC.7.6.6.4 Preconditions**

None.

#### **CC.7.6.6.5 Definitions and calculations**

Definition of Test Point 1 (TP1):

- $TP_1$  corresponds to OP3;
- $I_{EVSE\_intended\_1} = P_{EVSE\_max} / V_{EVSE\_max}$ ;
- $V_{EVSE\_intended\_1} = V_{EVSE\_max}$ .

Definition of Test Point 2 (TP2):

- $TP_2$  corresponds to OP4;
- $I_{EVSE\_intended\_2} = P_{EVSE\_max} / V_{EVSE\_max}$ ;
- $V_{EVSE\_intended\_2} = V_{EVSE\_max}$ .

#### **CC.7.6.6.6 Actions**

The following steps shall be done for each of the defined test points  $TP_n$ .

In each test point, the proximity fault shall be simulated by using both methods. That is, two tests (one opening  $S_{T1}$  and one closing  $S_{T2}$ ) shall be done for each test point.

- 1) Approach a test point  $TP_n$  as defined in CC.7.4. Wait until the EV supply equipment has reached a stable operation.
- 2) Simulate a proximity fault by
  - a) Opening  $S_{T1}$ , and
  - b) Closing  $S_{T2}$ .
- 3) Check if the expected results are achieved.

### CC.7.6.6.7 Expected results

The EV supply equipment shall perform an emergency shutdown. That means that the EV supply equipment shall

- turn off its CP oscillator to indicate an emergency shutdown in 20 ms or less (trigger time) after opening  $S_{T1}$  or closing  $S_{T2}$ ,
- reduce its present current at side B to  $\leq 5$  A and disable its side B in 30 ms or less (10 ms trigger time and 20 ms reaction time) after opening  $S_{T1}$  or closing  $S_{T2}$ ,
- reduce the present voltage at side B to  $\leq 60$  V between DC+ and DC– in 1 010 ms or less (10 ms trigger time and 1000 ms reaction time) after opening  $S_{T1}$  or closing  $S_{T2}$ , and
- reduce the present voltage at side B to  $< 60$  V between DC+ and the protective conductor, and between DC– and the protective conductor in 1 010 ms or less (10 ms trigger time and 1 000 ms reaction time) after opening  $S_{T1}$  or closing  $S_{T2}$ .

### CC.7.6.7 Load dump

#### CC.7.6.7.1 General

The test points  $TP_n$  for the test are shown in Figure CC.27.

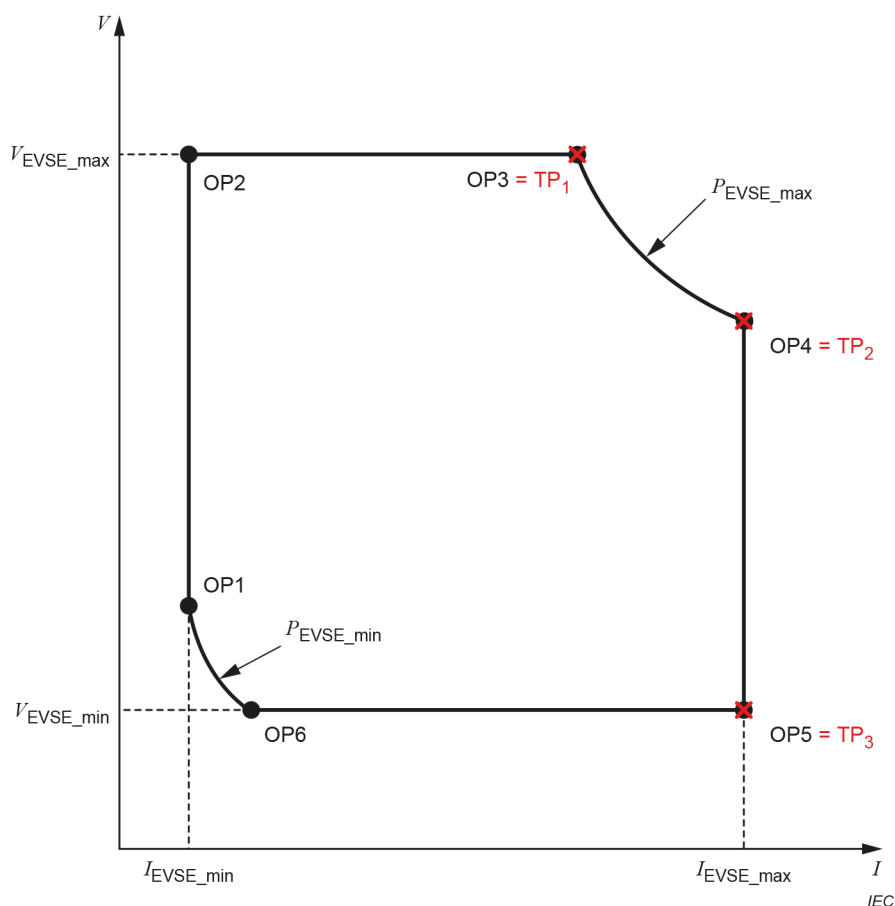

Figure CC.27 – Test points  $TP_n$  for the load dump test

#### CC.7.6.7.2 Reference requirements

This test case considers the following requirements:

- 101.1.7 Load dump;

- CC.6.1 Requirements for load dump.

### CC.7.6.7.3 Description

Check if the EV supply equipment limits the voltage overshoot to the specified values in case of a load dump.

### CC.7.6.7.4 Test setup

Standard test setup.

### CC.7.6.7.5 Preconditions

None.

### CC.7.6.7.6 Definitions and calculations

Definition of intended test points:

$TP_1 = (I_{EVSE\_intended\_1} / V_{EVSE\_intended\_1})$  with:

- $I_{EVSE\_intended\_1} = P_{EVSE\_max} / V_{EVSE\_max}$
- $V_{EVSE\_intended\_1} = V_{EVSE\_max}$
- $TP_1$  corresponds to OP3.

$TP_2 = (I_{EVSE\_intended\_2} / V_{EVSE\_intended\_2})$  with:

- $I_{EVSE\_intended\_2} = I_{EVSE\_max}$
- $V_{EVSE\_intended\_2} = P_{EVSE\_max} / I_{EVSE\_max}$
- $TP_2$  corresponds to OP4.

$TP_3 = (I_{EVSE\_intended\_3} / V_{EVSE\_intended\_3})$  with:

- $I_{EVSE\_intended\_3} = I_{EVSE\_max}$
- $V_{EVSE\_intended\_3} = V_{EVSE\_min}$
- $TP_3$  corresponds to OP5.

### CC.7.6.7.7 Actions

Repeat the following steps for each of the defined test points  $TP_n$ .

- 1) Approach the test point  $TP_n$  according to CC.7.4 using the target voltages as defined below:
  - $TP_1$ :  $EVTARGETVOLTAGE = V_{EV\_max\ 1} = V_{EVSE\_max} + 30\ V$ ;
  - $TP_2$ :  $EVTARGETVOLTAGE = V_{EV\_max\ 2} = (P_{EVSE\_max} / I_{EVSE\_max}) + 30\ V$ ;
  - $TP_3$ :  $EVTARGETVOLTAGE = V_{EV\_max\ 3} = V_{EVSE\_min} + 30\ V$ .
- 2) Open switch  $S_{T19}$  of the test load.
- 3) Measure  $V_{T8}$  for a duration of 3 s with a cut-off frequency of 2 MHz or more and a minimum sampling rate of 10 MS/s.
- 4) Check if expected results are achieved.

**CC.7.6.7.8 Expected results**

Verify that, for a duration of 3 s starting at 3 ms after opening of S<sub>T</sub>19,

$$V_{T8} \leq \max(110 \% \times V_{EV\_max}, V_{EV\_max} + 50 \text{ V}).$$

**CC.7.6.8 Limiting the inrush current by EV supply equipment****CC.7.6.8.1 Reference requirements**

This test case considers the following requirements:

- CC.5.1 Pre-charge.

**CC.7.6.8.2 Description**

Check if the EV supply equipment limits the inrush current according to the limits defined in CC.5.1.

**CC.7.6.8.3 Test setup**

Standard test setup, with the values specified Table CC.23.

**Table CC.23 – Component valued for the inrush current limit test**

Component	Value
L <sub>T</sub> 3, L <sub>T</sub> 4	≤ 2 μH
R <sub>T</sub> 5, R <sub>T</sub> 6	2 MΩ
R <sub>T</sub> 10	Variable
C <sub>T</sub> 6	470 μF
C <sub>T</sub> 7, C <sub>T</sub> 8	2 μF
R <sub>T</sub> 13, R <sub>T</sub> 14	500 kΩ

**CC.7.6.8.4 Preconditions**

Based on the data sheet of the EV supply equipment, the EV simulator shall communicate the following properties with the message "ChargeParameterDiscoveryReq" <3a>:

- $V_{EV\_max} \geq V_{EVSE\_max}$ ;
- $V_{EV\_min} \leq V_{EVSE\_min}$ ;
- $I_{EV\_max} \geq I_{EVSE\_max}$ ;
- $I_{EV\_min} \leq I_{EVSE\_min}$ ;
- $P_{EV\_max} \geq P_{EVSE\_max}$ .

The EV supply equipment has successfully communicated its following properties to the EV simulator:

- $V_{EVSE\_min}$ ;
- $V_{EVSE\_max}$ ;
- $I_{EVSE\_min}$ ;
- $I_{EVSE\_max}$ ;
- $P_{EVSE\_max}$ .

The normal startup sequence is performed until t6 with message "CableCheckRes" <4b> including the parameter "EVSEProcessing" = 'Finished'.

#### CC.7.6.8.5 Definitions and calculations

Measure the currents  $I_{EVSE\_SideB\_DC+}$  on DC+ conductor and  $I_{EVSE\_SideB\_DC-}$  on DC– conductor from time t7 to t11 with a cut-off frequency of 2 MHz or more, and a minimum sampling rate of 10 MS/s.

Definitions:

- the average (that is, the DC component) of  $I_{EVSE\_SideB\_DC+}$  from t7 to t11;
- the average (that is, the DC component) of  $I_{EVSE\_SideB\_DC-}$  from t7 to t11;
- the maximum peak of  $I_{EVSE\_SideB\_DC+}$  from CC.7.6.8.6 step 6) until the EV supply equipment receives message "PowerDeliveryReq" <6a> ;
- the maximum peak of  $I_{EVSE\_SideB\_DC-}$  from CC.7.6.8.6 step 6) until the EV supply equipment receives message "PowerDeliveryReq" <6a>;
- the maximum peak of  $I_{EVSE\_SideB\_DC+}$  from the reception of message "PowerDeliveryReq" <6a> until time t11;
- the maximum peak of  $I_{EVSE\_SideB\_DC-}$  from the reception of message "PowerDeliveryReq" <6a> until time t11;
- the integral of the current larger than 2 A over time ( $I_{> 2A} \times t$ ) from the reception of message "PowerDeliveryReq" <6a> until time t11.

#### CC.7.6.8.6 Actions

- 1) Send the first "PrechargeReq" <5a> message with the following parameter:
  - $EVTARGETVOLTAGE = V_{EV\_target} = V_{EVSE\_max}$ ;
  - the first "PreChargeReq" <5a> message corresponds to time t7.
- 2) Wait until the  $V_{EVSE\_SideB}$  has stabilized.
- 3) Close S<sub>T</sub>18.
- 4) Wait 1 s.
- 5) Close S<sub>T</sub>17.
- 6) Send message "PowerDeliveryReq" <6a> with parameter "ReadyToChargeState" = 'TRUE' (using DIN SPEC 70121:2014) or the parameter "ChargeProgress" = 'Start' (using ISO 15118-2:2014).
- 7) Wait until the EV supply equipment sends message "PowerDeliveryRes" <6b>.
- 8) Send message "CurrentDemandReq" <7a>. This point in time is t11.
- 9) Perform an additional test changing the switching devices closure order (close S<sub>T</sub>17 in step 3) and S<sub>T</sub>18 at step 5).

#### CC.7.6.8.7 Expected results

The test is passed if all the following conditions are met for both test runs:

- from t7 to t11, the average (that is, the DC component) of  $I_{EVSE\_SideB\_DC+}$  is limited to [–2 A; 2 A];
- from t7 to t11, the average (that is, the DC component) of  $I_{EVSE\_SideB\_DC-}$  is limited to [–2 A; 2 A];

- from CC.7.6.8.6 step 6) until the EV supply equipment receives the "PowerDeliveryReq" <6a> message, the lower amplitude of the maximum peak of  $I_{EVSE\_SideB\_DC+}$  and the maximum peak of  $I_{EVSE\_SideB\_DC-}$  is limited to [–20 A; 20 A];
- from the reception of the "PowerDeliveryReq" <6a> message until time t11, the maximum peak of  $I_{EVSE\_SideB\_DC+}$  is limited to [–125 A; 125 A];
- from the reception of the "PowerDeliveryReq" <6a> message until time t11, the maximum peak of  $I_{EVSE\_SideB\_DC-}$  is limited to [–125 A; 125 A];
- from the reception of the "PowerDeliveryReq" <6a> message until time t11, the integral of the current larger than 2 A over time ( $I_{>2A} \times t$ ) is limited to 3 As. See Formula (CC.17).

$$\int I_{>2A} dt \leq 3 \text{ As} \quad (\text{CC.17})$$

where

$I_{>2A}$  is the current > 2 A, expressed in ampere.

NOTE There is no compliance criteria for the maximum peak of  $I_{EVSE\_SideB\_DC+}$  or the maximum peak of  $I_{EVSE\_SideB\_DC-}$  at CC.7.6.8.6 step 4).

### **CC.7.6.9 Side B current regulation in CCM including static deviation and ripple**

#### **CC.7.6.9.1 General**

The test point matrix for the compliance test is shown in Figure CC.28.

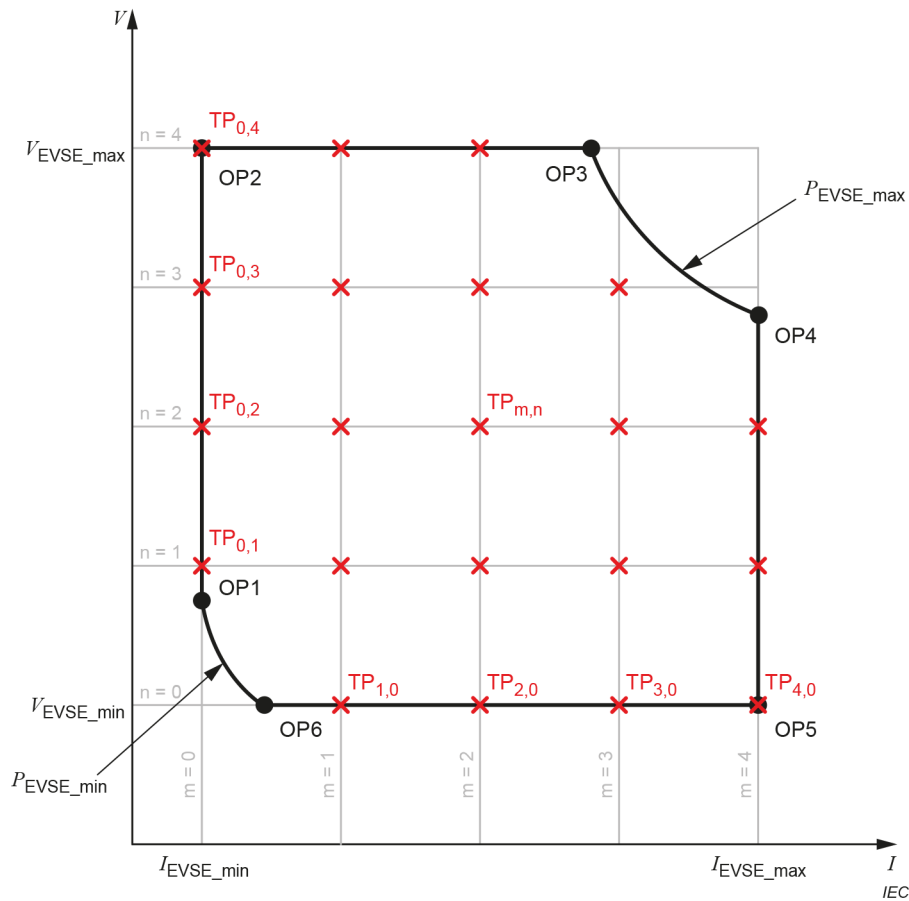

**Figure CC.28 – Test point matrix for side B current regulation in CCM including static deviation and ripple**

Figure CC.28 shows a simplified example of the test point matrix with indices  $m = 0 \dots 4$  and  $n = 0 \dots 4$  in order to visualize the principal testing sequence of this test case. However, the test point matrix that shall actually be used for this test case shall cover indices  $m = 0 \dots 20$  and  $n = 0 \dots 20$ , with some additional restrictions as described below. The following aspects shall be considered.

- Only the test points  $TP_{m,n}$  within the operating range of the EV supply equipment shall be considered for the requirement evaluation. Furthermore, the actual shape of the operating range may differ from the simplified shape as depicted in Figure CC.28. As a result, there might be one or more test points in which the EV supply equipment cannot be operated. Those test points shall not be considered for the requirement evaluation.
- The operating range of the EV supply equipment may dynamically change during the test, for example, due to thermal degradation. As a result, there might be single test points in which the EV supply equipment can no longer be operated, as opposed to the initial determination of the test point matrix at the beginning of the test. Those test points shall not be considered for the requirement evaluation.

**CC.7.6.9.2 Reference requirements**

This test case considers the following requirements:

- 101.1.1 Operating ranges for voltage, current, and power at side B;
- 101.1.2.1 Side B current regulation in CCM;
- 101.1.5 Periodic and random deviation (current ripple);
- 6.3.1.102 Measuring current and voltage;
- CC.6.2 Side B current regulation;

- CC.6.3 Measuring current and voltage.

#### CC.7.6.9.3 Description

Check if the current regulation fulfils the requirements for static, periodic, and random deviation.

Check the accuracy of the current and voltage measurements.

#### CC.7.6.9.4 Test setup

Standard test setup.

#### CC.7.6.9.5 Preconditions

Based on the data sheet of the EV supply equipment, the EV simulator shall communicate the following properties with the message "ChargeParameterDiscoveryReq" <3a>:

- $V_{EV\_max} \geq V_{EVSE\_max}$ ;
- $V_{EV\_min} \leq V_{EVSE\_min}$ ;
- $I_{EV\_max} \geq I_{EVSE\_max}$ ;
- $I_{EV\_min} \leq I_{EVSE\_min}$ ;
- $P_{EV\_max} \geq P_{EVSE\_max}$ .

The EV supply equipment has successfully communicated its following properties to the EV simulator with the message "ChargeParameterDiscoveryRes" <3b>:

- $V_{EVSE\_min}$ ;
- $V_{EVSE\_max}$ ;
- $I_{EVSE\_min}$ ;
- $I_{EVSE\_max}$ ;
- $P_{EVSE\_max}$ .

#### CC.7.6.9.6 Definitions and calculations

In the steps of this test case, certain properties of the EV supply equipment are tested at specific test points in the operating range of the EV supply equipment. The indices "m" and "n" are used as follows to refer to a specific test point  $TP_{m,n}$ :

- m: this index is used to identify the value of the intended current;
- n: this index is used to identify the value of the intended voltage.

The message "CurrentDemandReq" <7a> shall contain the following parameters:

- $EVTargetCurrent = I_{EV\_target}$ ;
- $EVTargetVoltage = V_{EV\_target}$ ;

and shall be cyclically sent by the EV simulator with a cycle time of 1 s or less.

Definition of test point matrix  $TP_{m,n}$ :

Indices range:

- $m = 0 \dots 20$ ;
- $n = 0 \dots 20$ .

$TP_{m,n} = (I_{EVSE\_intended\_m} / V_{EVSE\_intended\_n})$  with:

- $I_{EVSE\_intended\_m} = I_{EVSE\_min} + m/20 \times (I_{EVSE\_max} - I_{EVSE\_min})$ ;
- $V_{EVSE\_intended\_n} = V_{EVSE\_min} + n/20 \times (V_{EVSE\_max} - V_{EVSE\_min})$ .

A test point of the grid is valid for testing if all of the following conditions are fulfilled:

- $V_{EVSE\_intended\_n} \times I_{EVSE\_intended\_m} \leq P_{EVSE\_max}$ ;
- $V_{EVSE\_intended\_n} \times I_{EVSE\_intended\_m} \geq P_{EVSE\_min}$ ;
- the test point is contained in the operating range of the EV supply equipment as communicated by the EV supply equipment in the initialization phase (ChargeParameterDiscoveryReq/Res) and during the energy transfer stage (CurrentDemandReq/Res).

Target values requested to approach test point  $TP_{m,n}$ :

- $I_{EV\_target} = I_{EVSE\_intended\_m}$ ;
- $V_{EV\_target} = V_{EVSE\_max}$  (to allow for CCM).

The EV simulator shall cyclically sent "CurrentDemandReq" <7a> messages with a cycle time of 1 s or less in order to enable the EV supply equipment to communicate its (potentially) adapted operating range in "CurrentDemandRes" <7b>.

Calculations done continuously during the measurement duration of each  $TP_{m,n}$ :

- Determine the absolute deviation:
  - $I_{dev\_abs} = |I_{EVSE\_SideB\_DC} - I_{EV\_target}|$  for  $I_{EV\_target} \leq 50$  A
- Determine the relative deviation:
  - $I_{dev\_rel} = |I_{EVSE\_SideB\_DC} - I_{EV\_target}| / I_{EV\_target}$  for  $I_{EV\_target} > 50$  A
- Determine the absolute deviation:
  - $I_{dev\_abs\_measure} = |I_{EVSE\_measure} - I_{EVSE\_SideB\_DC}|$   
with  $I_{EVSE\_measure} = EVSEPresentCurrent$  of the message "CurrentDemandRes" <7b>
- Determine the absolute deviation:
  - $V_{dev\_abs\_measure} = |V_{EVSE\_measure} - V_{EVSE\_SideB\_DC}|$   
with  $V_{EVSE\_measure} = EVSEPresentVoltage$  of the message "CurrentDemandRes" <7b>

The test points of the test point matrix shall be processed in the sequence described in Figure CC.29:

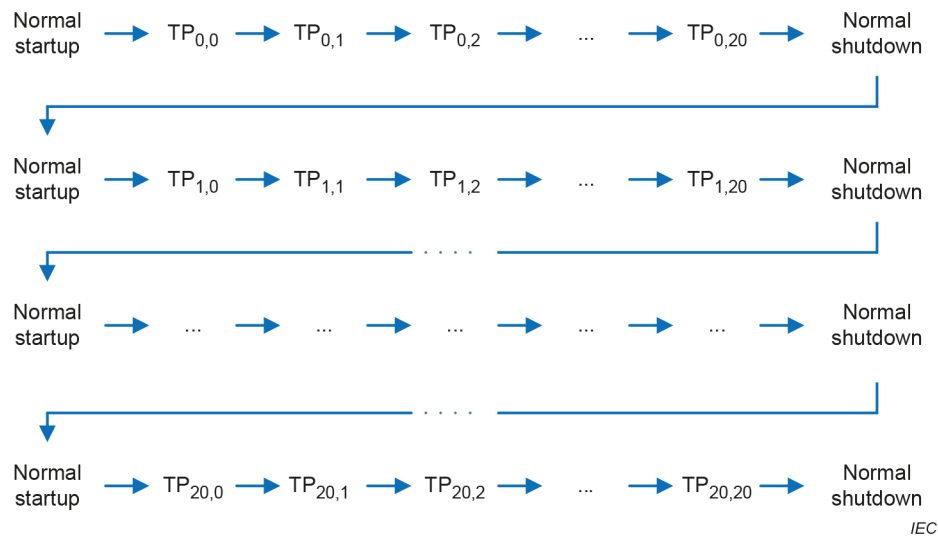

**Figure CC.29 – Test point sequence for side B current regulation in CCM**

#### CC.7.6.9.7 Actions

Only valid test points shall be considered for the test.

Each of the test points shall be approached according to CC.7.4.

Actions for each of the test points:

- 1) measure  $I_{EVSE\_SideB\_DC}$ ,  $I_{rip\_low}$ ,  $I_{rip\_mid}$  and  $I_{rip\_high}$ ;
- 2) receive  $I_{EVSE\_measure}$  and  $V_{EVSE\_measure}$ ;
- 3) perform calculations to be done for each test point TP<sub>m,n</sub>;
- 4) check if expected results are achieved.

#### CC.7.6.9.8 Expected results

This test case is passed if each of the following test criteria is fulfilled for each TP<sub>m,n</sub>:

- for  $I_{EV\_target} \leq 5$  A:  
 $I_{dev\_abs} \leq 150$  mA;
- for  $5$  A <  $I_{EV\_target} \leq 50$  A:  
 $I_{dev\_abs} \leq 1,5$  A;
- for  $I_{EV\_target} > 50$  A:  
 $I_{dev\_rel} \leq 3$  %;
- $I_{dev\_abs\_measure} \leq \max(1,5 \% \text{ of } I_{EVSE\_measure} / 0,5 \text{ A})$ ;
- $V_{dev\_abs\_measure} \leq 10$  V;
- the current ripple shall meet the limits shown in Table CC.24.

**Table CC.24 – Current ripple limits**

	Current ripple, $A_{\text{peak-to-peak}}$		
	$I_{\text{EVSE\_SideB\_DC}} \leq 200 \text{ A}$	$200 \text{ A} < I_{\text{EVSE\_SideB\_DC}} \leq 400 \text{ A}$	$I_{\text{EVSE\_SideB\_DC}} > 400 \text{ A}$
$I_{\text{rip\_low}}$	$\leq 1,5$	$\leq (I_{\text{EVSE\_SideB\_DC}} \times 0,75 \%)$	$\leq (I_{\text{EVSE\_SideB\_DC}} \times 0,75 \%)$
$I_{\text{rip\_mid}}$	$\leq 6,0$	$\leq 6,0$	$\leq (I_{\text{EVSE\_SideB\_DC}} \times 1,5 \%)$
$I_{\text{rip\_high}}$	$\leq 9,0$	$\leq (I_{\text{EVSE\_SideB\_DC}} \times 4,5 \%)$	$\leq (I_{\text{EVSE\_SideB\_DC}} \times 4,5 \%)$

**CC.7.6.10 0 A mode during energy transfer**

**CC.7.6.10.1 General**

The test point matrix for the compliance test is shown in Figure CC.30.

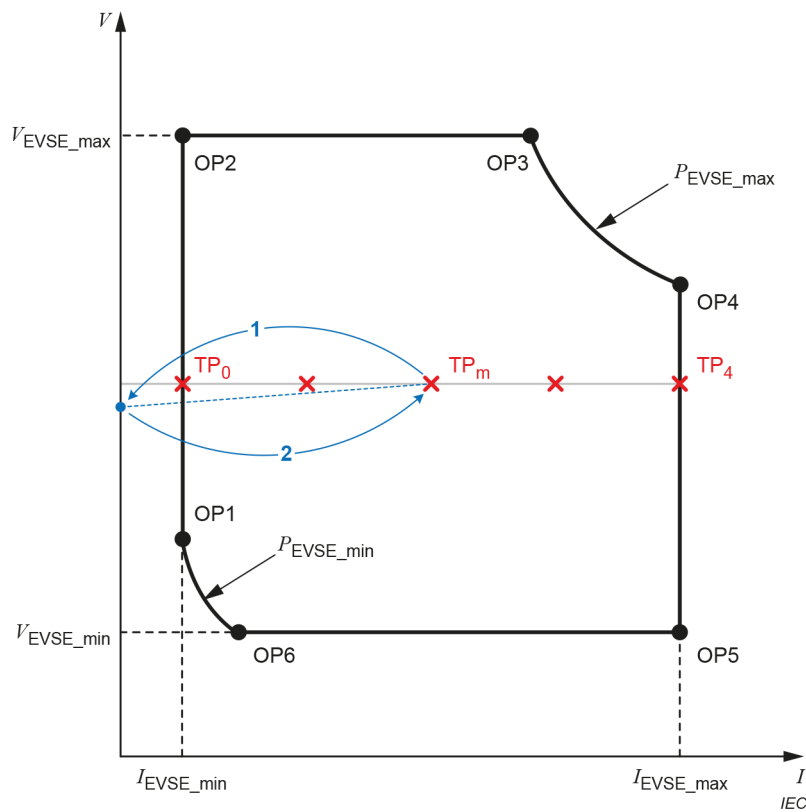

**Figure CC.30 – Test point matrix for 0 A mode during energy transfer**

Figure CC.30 shows a simplified example of the test points with index  $m = 0 \dots 4$  in order to visualize the principal testing sequence of this test case. However, the test points that shall actually be used for this test case shall cover indices  $m = 0 \dots 20$ , with some additional restrictions as described below. The following aspects shall be considered.

- The actual shape of the operating range may differ from the simplified shape as depicted in Figure CC.30. As a result, there might be one or more test points in which the EV supply equipment cannot be operated. Those test points shall not be considered for the requirement evaluation.

- The operating range of the EV supply equipment may dynamically change during the test, for example, due to thermal degradation. As a result, there might be single test points in which the EV supply equipment can no longer be operated, as opposed to the initial determination of the test points at the beginning of the test. Those test points shall not be considered for the requirement evaluation.

#### CC.7.6.10.2 Reference requirements

This test case considers the following requirements:

- 6.3.1.102 Measuring current and voltage;
- CC.5.5.2 0 A mode during energy transfer;
- CC.6.3 Measuring current and voltage.

#### CC.7.6.10.3 Description

Check if the current regulation fulfils the requirements for 0 A mode.

Check accuracy of current and voltage measurement.

#### CC.7.6.10.4 Test setup

Standard test setup.

#### CC.7.6.10.5 Preconditions

None.

#### CC.7.6.10.6 Definitions and calculations

In the steps of this test case, certain properties of the EV supply equipment are tested at specific test points in the operating range of the EV supply equipment. The index  $m$  is used as follows to refer to a specific test point  $TP_m$ :

$m$ : This consecutive index is used to identify the value of the intended current.

The message "CurrentDemandReq" <7a> shall contain the following parameters:

- EVTargetCurrent =  $I_{EV\_target}$ ;
- EVTargetVoltage =  $V_{EV\_target}$ .

Definition of test points  $TP_m$ :

Index range:

- $m = 0 \dots 20$ .

$TP_m = (I_{EVSE\_intended\_m} / V_{EVSE\_intended})$  with:

- $I_{EVSE\_intended\_m} = I_{EVSE\_min} + m/20 \times (I_{EVSE\_max} - I_{EVSE\_min})$ ;
- $V_{EVSE\_intended} = V_{EVSE\_min} + 0,5 \times (V_{EVSE\_max} - V_{EVSE\_min})$ .

A test point of the grid is valid for testing if all of the following conditions are fulfilled:

- $V_{EVSE\_intended} \times I_{EVSE\_intended\_m} \leq P_{EVSE\_max}$ ;
- $V_{EVSE\_intended} \times I_{EVSE\_intended\_m} \geq P_{EVSE\_min}$ ;

- The test point is contained in the operating range of the EV supply equipment as communicated by the EV supply equipment in the initialization phase (ChargeParameterDiscoveryReq/Res) and during the energy transfer stage (CurrentDemandReq/Res).

Target values requested to approach test points  $TP_n$ :

- $I_{EV\_target\_m} = I_{EVSE\_intended\_m}$ ;
- $V_{EV\_target} = V_{EVSE\_max}$  (to allow for CCM);
- the EV simulator shall cyclically send "CurrentDemandReq" <7a> messages with a cycle time of 1 s or less in order to enable the EV supply equipment to communicate its (potentially) adapted operating range in "CurrentDemandRes" <7b>.

Calculations done continuously during the measurement duration of each  $TP_n$ :

- Determine the absolute deviation:
  - $I_{dev\_abs} = |I_{EVSE\_SideB\_DC} - I_{EV\_target}|$
- Determine the absolute deviation:
  - $I_{dev\_abs\_measure} = |I_{EVSE\_measure} - I_{EVSE\_SideB\_DC}|$   
with  $I_{EVSE\_measure} = EVSEPresentCurrent$  of the message "CurrentDemandRes" <7b>
- Determine the absolute deviation:
  - $V_{dev\_abs\_measure} = |V_{EVSE\_measure} - V_{EVSE\_SideB\_DC}|$   
with  $V_{EVSE\_measure} = EVSEPresentVoltage$  of the message "CurrentDemandRes" <7b>
- Transition time:
  - $T_{transition\_max} = \max \left( 1s, \frac{|I_{Req\_ACK} - I_{EVSE\_output}(t_0)|}{20 \frac{A}{s}} \right)$

#### CC.7.6.10.7 Actions

Each of the test points shall be approached according to CC.7.4. For each of the test points perform the following steps.

Step 1:

- 1) Request target values with the following parameters in the message "CurrentDemandReq" <7a>:
  - EVTargetCurrent =  $I_{EV\_target} = 0$  A;
  - EVTargetVoltage =  $V_{EV\_target} = V_{EVSE\_max}$ .
- 2) Wait for  $T_{transition\_max}$ .
- 3) Measure  $I_{EVSE\_SideB\_DC}$ .
- 4) Receive  $I_{EVSE\_measure}$  and  $V_{EVSE\_measure}$ .
- 5) Perform calculations to be done for each test point  $TP_m$ .
- 6) Check if expected results are achieved.

Step 2:

1) Request target values with the following parameters in the message "CurrentDemandReq" <7a>, that is, go back to starting test point:

- EVTargetCurrent =  $I_{EV\_target\_m} = I_{EVSE\_intended\_m}$ ;
- EVTargetVoltage =  $V_{EV\_target} = V_{EVSE\_max}$ .

#### CC.7.6.10.8 Expected results

This test case is passed if each of the following test criteria is fulfilled for each  $TP_m$ .

After step 1:

- $I_{dev\_abs} \leq 150$  mA;
- $I_{dev\_abs\_measure} \leq 0,5$  A;
- $V_{dev\_abs\_measure} \leq 10$  V.

After step 2:

The EV supply equipment approaches the starting test point and remains in the energy transfer stage.

#### CC.7.6.11 Side B voltage regulation in CVM during pre-charge

##### CC.7.6.11.1 General

The test point matrix for the compliance test is shown in Figure CC.31.

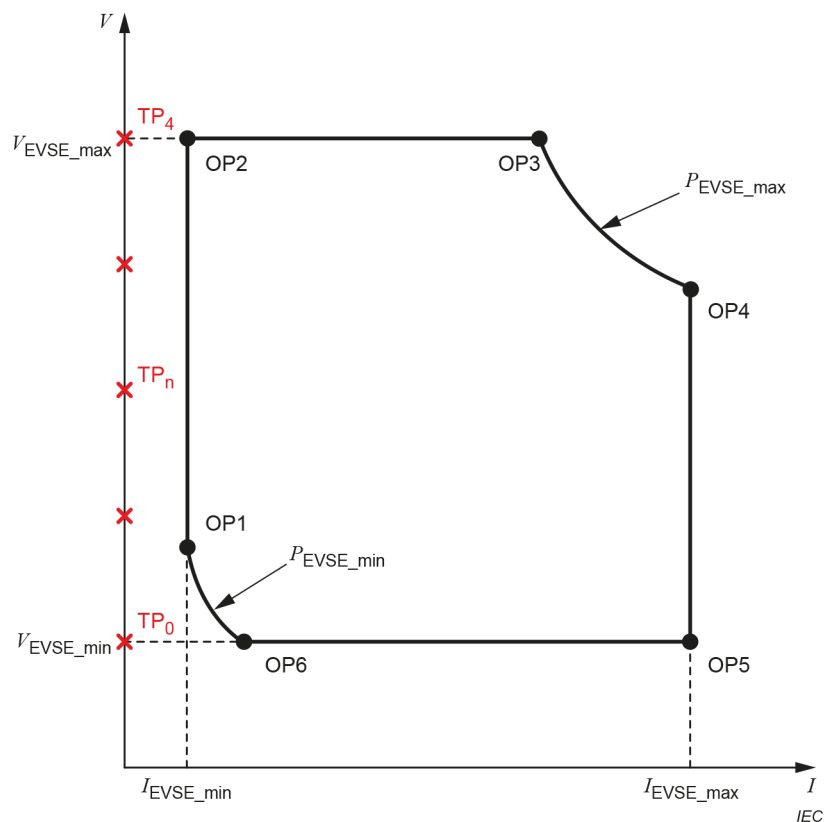

Figure CC.31 – Test point matrix for side B voltage regulation in CVM during pre-charge

Figure CC.31 shows a simplified example of the test points with index  $n = 0 \dots 4$  in order to visualize the principal testing sequence of this test case. However, the test points that shall actually be used for this test case shall cover index  $n = 0 \dots 20$ , with some additional restrictions as described below. The following aspects shall be considered.

- Only the test points  $TP_n$  within the operating range of the EV supply equipment shall be considered for the requirement evaluation. Furthermore, the actual shape of the operating range may differ from the simplified shape as depicted in Figure CC.31. As a result, there might be one or more test points in which the EV supply equipment cannot be operated. Those test points shall not be considered for the requirement evaluation.
- The operating range of the EV supply equipment may dynamically change during the test, for example, due to thermal degradation. As a result, there might be single test points in which the EV supply equipment can no longer be operated, as opposed to the initial determination of the test point grid at the beginning of the test. Those test points shall not be considered for the requirement evaluation.

#### **CC.7.6.11.2 Reference requirements**

This test case considers the following requirements:

- 6.3.1.102 Measuring current and voltage;
- 101.1.2.2 Side B voltage regulation in CVM;
- 101.1.6 Periodic and random deviation (voltage ripple in CVM);
- CC.5.1 Pre-charge;
- CC.6.3 Measuring current and voltage.

#### **CC.7.6.11.3 Description**

Check if the voltage regulation during pre-charge fulfils the requirements for static, periodic, and random deviation.

Check if the EV supply equipment ignores the current request of the EV and limits the continuous current on DC+ and on DC– of the present current at side B in both directions to a maximum of 2 A.

Check accuracy of voltage measurement.

#### **CC.7.6.11.4 Test setup**

Modified standard test setup as shown in Figure CC.14.

Use the values for the test setup specified in Table CC.25.

**Table CC.25 – Test setup values to measure side B voltage regulation in CVM during pre-charge**

Symbol	Value for test load during pre-charge	
	Setup 1	Setup 2
$I_{T1}$	12 mA ± 2 mA	0 mA
$C_{T1}, C_{T2}$	2 µF ± 20 %	2 µF ± 20 %
$C_{T9}$	10 nF ± 20 %	10 nF ± 20 %
$R_{T5}, R_{T6}$	300 kΩ $\begin{smallmatrix} +20 \\ 0 \end{smallmatrix}$ %	300 kΩ $\begin{smallmatrix} +20 \\ 0 \end{smallmatrix}$ %
$R_{T16}, R_{T17}$	500 kΩ ± 10 %	2 MΩ ± 10 %
$S_{T11}, S_{T12}, S_{T13},$ $S_{T14}, S_{T17}$	closed	closed
$S_{T18}$	open	open

Measure in the stationary phase for a duration of 10 s.

All measurements during this time shall be used for calculation and for verification of expected results.

#### CC.7.6.11.5 Preconditions

Based on the data sheet of the EV supply equipment, the EV simulator shall communicate the following properties with the message "ChargeParameterDiscoveryReq" <3a>:

- $V_{EV\_max} \geq V_{EVSE\_max}$ ;
- $V_{EV\_min} \leq V_{EVSE\_min}$ ;
- $I_{EV\_max} \geq I_{EVSE\_max}$ ;
- $I_{EV\_min} \leq I_{EVSE\_min}$ ;
- $P_{EV\_max} \geq P_{EVSE\_max}$ .

The EV supply equipment has successfully communicated its following properties to the EV simulator with the message "ChargeParameterDiscoveryRes" <3b>:

- $V_{EVSE\_min}$ ;
- $V_{EVSE\_max}$ ;
- $I_{EVSE\_min}$ ;
- $I_{EVSE\_max}$ ;
- $P_{EVSE\_max}$ .

#### CC.7.6.11.6 Definitions and calculations

In the steps of this test case, certain properties of the EV supply equipment are tested at specific test points in the operating range of the EV supply equipment. The index n is used as follows to refer to a specific test point  $TP_n$ :

n: This consecutive index is used to identify the value of the intended voltage.

The message "PreChargeReq" <5a> shall contain the following parameters:

- EVTargetCurrent =  $I_{EV\_target}$ ;
- EVTargetVoltage =  $V_{EV\_target}$ .

Definition of test points  $TP_n$ :

Index range:

$$n = 0 \dots 20$$

$TP_n = (0 \text{ A} / V_{EVSE\_intended\ n})$  with:

- $V_{EVSE\_intended\ n} = V_{EVSE\_min} + n/20 \times (V_{EVSE\_max} - V_{EVSE\_min})$ .

Target values requested to approach test points  $TP_n$ :

- $I_{EV\_target} = 10 \text{ A}$ ;
- $V_{EV\_target} = V_{EVSE\_intended\ n}$ .

The EV simulator shall request a target current  $> 2 \text{ A}$ , to test if the EV supply equipment ignores the target current of the EV (even if it momentarily enters CCM while adjusting the present voltage at side B), and limits the present current at side B to  $2 \text{ A}$ .

Definition of times:

- $T_{wait\_1} = 3 \text{ s}$  (according to CC.5.1);
- $T_{wait\_2} = 1 \text{ s}$  (according to CC.5.1).

Calculations done continuously during the measurement duration of each  $TP_n$ :

- Determine the relative deviation:
  - $V_{dev\_rel\_1} = |V_{EVSE\_SideB\_DC} - V_{EV\_target}| / V_{EV\_target}$
- Determine the relative deviation:
  - $V_{dev\_rel\_2} = |V_{EVSE\_SideB\_DC} - V_{EV\_target}| / V_{EVSE\_max}$
- Determine the absolute deviation:
  - $V_{dev\_abs\_measure} = |V_{EVSE\_measure} - V_{EVSE\_SideB\_DC}|$   
with  $V_{EVSE\_measure} = \text{EVSEPresentVoltage of the message "PreChargeRes" <5b>}$

#### CC.7.6.11.7 Actions

This test consists of three parts, covering the requirements for voltage regulation in different time sections of the pre-charge stage as specified in CC.5.1. To test parts (I) and (II), setup 1 shall be used; to test part (III), setup 2 shall be used.

The test points  $TP_n$  shall be covered in a sequence generated by a test loop.

The loop shall cover the index range of index  $n$  ( $n = 0\dots20$ ) and therefore step through the different values of the intended voltage.

Part (I): Test of voltage regulation after 3 s:

Configure the test setup with the values of setup 1. Close  $S_T11$ ,  $S_T12$ ,  $S_T13$  and  $S_T14$ .

- 1) Set  $n = 0$ .
- 2) Loop:
  - a) Perform FPT sequence until the EV supply equipment has communicated that the cable-check phase has been completed with the message "CableCheckRes" <4b> (that is,  $t = t_6$  according to CC.3.2).
  - b) Request target values with the following parameters in the message "PreChargeReq" <5a>:
 
$$\text{EVTargetCurrent} = I_{\text{EV\_target}} = 10 \text{ A}$$

$$\text{EVTargetVoltage} = V_{\text{EV\_target}} = V_{\text{EVSE\_intended\_n}}$$
  - c) Wait for  $T_{\text{wait\_1}}$  (starting point: "PreChargeReq" <5a> message is sent).
  - d) Measure  $V_{\text{EVSE\_SideB\_DC}}$ ,  $V_{\text{rip}}$ , and  $I_{\text{EVSE\_SideB}}$ .
  - e) Receive  $V_{\text{EVSE\_measure}}$ .
  - f) Perform calculations to be done for each test point  $\text{TP}_n$ .
  - g) Check if expected results are achieved (after  $T_{\text{wait\_1}}$  is elapsed).
  - h) Perform a normal shutdown according to CC.3.3.
  - i) Set  $n = n + 1$ .
  - j) If  $n \leq 20$ , then jump to step a).
- 3) End test part (I).

Part (II): Test of voltage regulation 1 s after increase of voltage request by 50 V:

Configure the test setup with the values of setup 1. Close  $S_{T11}$ ,  $S_{T12}$ ,  $S_{T13}$  and  $S_{T14}$ .

- 4) Set  $n = 0$ .
- 5) Loop:
  - a) Perform FPT sequence until the EV supply equipment has communicated that the cable-check phase has been completed with the message "CableCheckRes" <4b> (that is,  $t = t_6$  according to CC.3.2).
  - b) Request target values with the following parameters in the message "PreChargeReq" <5a>:
 
$$\text{EVTargetCurrent} = I_{\text{EV\_target}} = 10 \text{ A};$$

$$\text{EVTargetVoltage} = V_{\text{EV\_target}} = V_{\text{EVSE\_intended\_n}}$$
  - c) Wait for  $T_{\text{wait\_1}}$  (starting point: "PreChargeReq" <5a> message in b) is sent).
  - d) Request target values with the following parameters in the message "PreChargeReq" <5a>:
 
$$\text{EVTargetCurrent} = I_{\text{EV\_target}} = 10 \text{ A};$$

$$\text{EVTargetVoltage} = V_{\text{EV\_target}} = V_{\text{EVSE\_intended\_n}} + 50 \text{ V}.$$
  - e) Wait for  $T_{\text{wait\_2}}$  (starting point: "PreChargeReq" <5a> message in d) is sent).
  - f) Measure  $V_{\text{EVSE\_SideB\_DC}}$ ,  $V_{\text{rip}}$ , and  $I_{\text{EVSE\_SideB}}$ .
  - g) Receive  $V_{\text{EVSE\_measure}}$ .
  - h) Perform calculations to be done for each test point  $\text{TP}_n$ .
  - i) Check if expected results are achieved (after  $T_{\text{wait\_2}}$  is elapsed).
  - j) Perform a normal shutdown according to CC.3.3.
  - k) Set  $n = n + 1$ .

l) If  $[(n \leq 20) \text{ and } (V_{EVSE\_intended\_n} \leq V_{EVSE\_max} - 50 \text{ V})]$ , then jump to step a).

6) End test part (II).

Part (III): Test of voltage regulation 1 s after decrease of voltage request by 50 V:

Configure the test setup with the values of setup 2. Close  $S_{T11}$ ,  $S_{T12}$ ,  $S_{T13}$  and  $S_{T14}$ .

7) Set  $n = 20$ .

8) Loop:

a) Perform FPT sequence until the EV supply equipment has communicated that the cable-check phase has been completed with the message "CableCheckRes" <4b> (that is,  $t = t_6$  according to CC.3.2).

b) Request target values with the following parameters in the message "PreChargeReq" <5a>:

$$EVTargetCurrent = I_{EV\_target} = 10 \text{ A};$$

$$EVTargetVoltage = V_{EV\_target} = V_{EVSE\_intended\_n}$$

c) Wait for  $T_{wait\_1}$  (starting point: "PreChargeReq" <5a> message in b) is sent)

d) Request target values with the following parameters in the message "PreChargeReq" <5a>:

$$EVTargetCurrent = I_{EV\_target} = 10 \text{ A};$$

$$EVTargetVoltage = V_{EV\_target} = V_{EVSE\_intended\_n} - 50 \text{ V}.$$

e) Wait for  $T_{wait\_2}$  (starting point: "PreChargeReq" <5a> message in d) is sent).

f) Measure  $V_{EVSE\_SideB\_DC}$ ,  $V_{rip}$ , and  $I_{EVSE\_SideB}$ .

g) Receive  $V_{EVSE\_measure}$ .

h) Perform calculations to be done for each test point  $TP_n$ .

i) Check if expected results are achieved (after  $T_{wait\_2}$  is elapsed).

j) Perform a normal shutdown according to CC.3.3.

k) Set  $n = n - 1$ .

l) If  $[(n \geq 0) \text{ and } (V_{EVSE\_intended\_n} \geq V_{EVSE\_min} + 50 \text{ V})]$ , then jump to step a).

9) End test part (III).

#### CC.7.6.11.8 Expected results

This test case is passed if each of the following test criteria is fulfilled for each  $TP_n$  and for each test part (I), (II), (III):

- $V_{dev\_rel\_1} \leq 5 \%$ ;
- $V_{dev\_rel\_2} \leq 2 \%$ ;
- for  $V_{EV\_target} \leq 500 \text{ V}$ :  
 $V_{rip} \leq 5 \text{ V}$ ;
- for  $V_{EV\_target} > 500 \text{ V}$ :  
 $V_{rip} \leq 1 \%$  of  $V_{EV\_target}$ ;
- $-2 \text{ A} \leq I_{EVSE\_SideB} \leq 2 \text{ A}$ ;
- $V_{dev\_abs\_measure} \leq 10 \text{ V}$ .

## CC.7.6.12 Control delay of present current at side B in CCM

### CC.7.6.12.1 General

The test point matrix for the compliance test is shown in Figure CC.32.

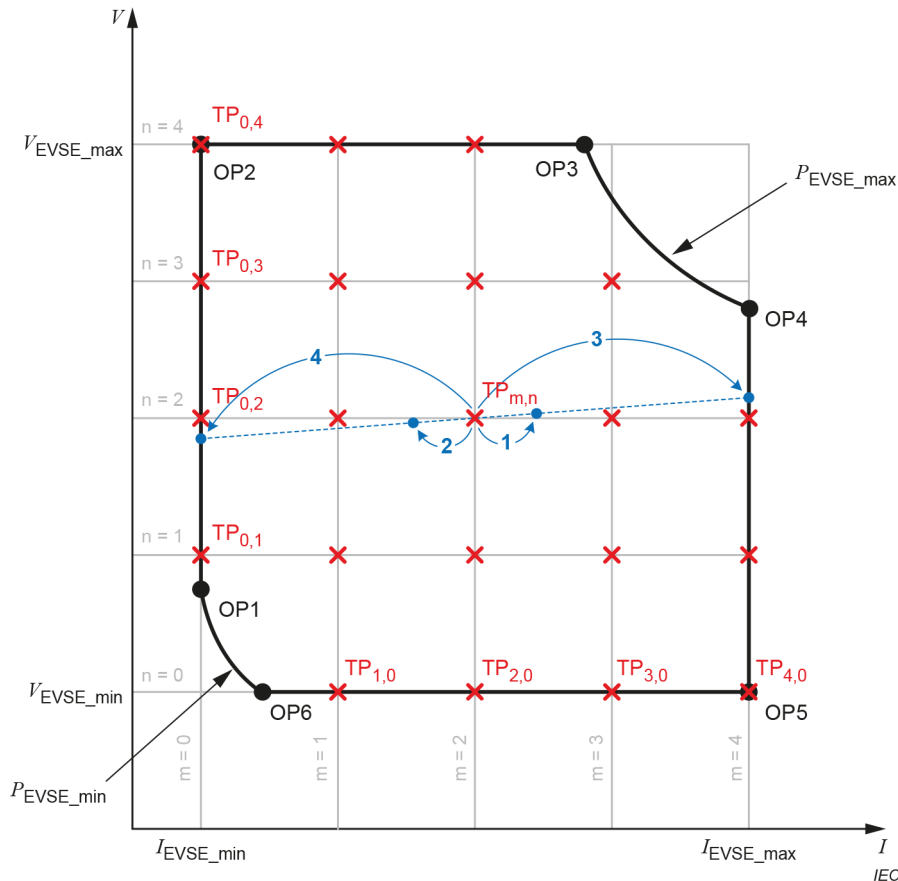

**Figure CC.32 – Test point matrix for control delay of charging current in CCM**

Figure CC.32 shows a simplified example of the test point matrix with indices  $m = 0 \dots 4$  and  $n = 0 \dots 4$ . However, the test point matrix that shall actually be used for this test case shall cover indices  $m = 0 \dots 20$  and  $n = 0 \dots 20$ , with some additional restrictions as described below.

Only the test points  $TP_{m,n}$  within the operating range of the EV supply equipment shall be considered for the requirement evaluation.

### CC.7.6.12.2 Reference requirements

This test case considers the following requirements:

- 101.1.1 Operating ranges for voltage, current, and power;
- 101.1.2.1 Side B current regulation in CCM;
- 101.1.3 Control delay of present current at side B in CCM;
- 101.1.5 Periodic and random deviation (current ripple at side B during CCM);
- CC.6.2 Side B current regulation.

### CC.7.6.12.3 Description

Check if the current regulation fulfils the requirements for control delay.

#### CC.7.6.12.4 Test setup

Standard test setup.

#### CC.7.6.12.5 Preconditions

Based on the data sheet of the EV supply equipment, the EV simulator shall communicate the following properties with the message "ChargeParameterDiscoveryReq" <3a>:

- $V_{EV\_max} \geq V_{EVSE\_max}$ ;
- $V_{EV\_min} \leq V_{EVSE\_min}$ ;
- $I_{EV\_max} \geq I_{EVSE\_max}$ ;
- $I_{EV\_min} \leq I_{EVSE\_min}$ ;
- $P_{EV\_max} \geq P_{EVSE\_max}$ .

The EV supply equipment shall have successfully communicated the following properties to the EV simulator with the message "ChargeParameterDiscoveryRes" <3b>:

- $V_{EVSE\_min}$ ;
- $V_{EVSE\_max}$ ;
- $I_{EVSE\_min}$ ;
- $I_{EVSE\_max}$ ;
- $P_{EVSE\_max}$ .

#### CC.7.6.12.6 Definitions and calculations

In the steps of this test case, certain properties of the EV supply equipment are tested at specific test points in the operating range of the EV supply equipment. The indices  $m$  and  $n$  are used as follows to refer to a specific test point  $TP_{m,n}$ :

- $m$ : this index is used to identify the value of the intended current;
- $n$ : this index is used to identify the value of the intended voltage.

The message "CurrentDemandReq" <7a> shall contain the following parameters:

- $EVTargetCurrent = I_{EV\_target}$ ;
- $EVTargetVoltage = V_{EV\_target}$ ;

and shall be cyclically sent by the EV simulator with a cycle time of 1 s or less.

Definition of test point matrix  $TP_{m,n}$ :

Indices range:

- $m = 0 \dots 20$ ;
- $n = 0 \dots 20$ .

$TP_{m,n} = (I_{EVSE\_intended\_m} / V_{EVSE\_intended\_n})$  with:

- $I_{EVSE\_intended\_m} = I_{EVSE\_min} + m/20 \times (I_{EVSE\_max} - I_{EVSE\_min})$ ;
- $V_{EVSE\_intended\_n} = V_{EVSE\_min} + n/20 \times (V_{EVSE\_max} - V_{EVSE\_min})$ .

A test point of the grid is valid for testing if all of the following conditions are fulfilled:

- $V_{EVSE\_intended\_n} \times I_{EVSE\_intended\_m} \leq P_{EVSE\_max}$ ;
- $V_{EVSE\_intended\_n} \times I_{EVSE\_intended\_m} \geq P_{EVSE\_min}$ ;
- the test point is contained in the operating range of the EV supply equipment as communicated by the EV supply equipment in the initialization phase (ChargeParameterDiscoveryReq/Res) and during the energy transfer stage (CurrentDemandReq/Res).

Target values requested to approach test point  $TP_{m,n}$ :

- $I_{EV\_target\_m} = I_{EVSE\_intended\_m}$ ;
- $V_{EV\_target} = V_{EVSE\_max}$  (to allow for CCM);
- the EV simulator shall cyclically sent "CurrentDemandReq" <7a> messages with a cycle time of 1 s or less in order to enable the EV supply equipment to communicate its (potentially) adapted operating range in "CurrentDemandRes" <7b>.

Calculations done continuously after  $T_{transition\_max}$  has elapsed (after  $I_{EV\_target}$  has been increased /decreased):

- determine the absolute deviation:
  - $I_{dev\_abs} = |I_{EVSE\_SideB\_DC} - I_{EV\_target}|$  for  $I_{EV\_target} \leq 50$  A;
- determine the relative deviation:
  - $I_{dev\_rel} = |I_{EVSE\_SideB\_DC} - I_{EV\_target}| / I_{EV\_target}$  for  $I_{EV\_target} > 50$  A

The test points of the test point matrix shall be processed in the sequence shown in Figure CC.33.

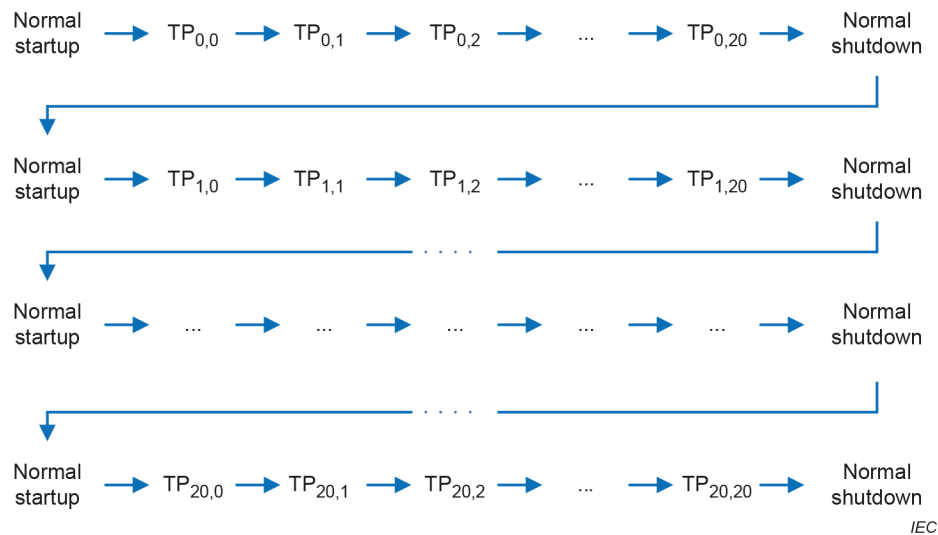

**Figure CC.33 – Test point sequence**

Only valid test points shall be considered for the test.

### CC.7.6.12.7 Actions

Each of the test points shall be approached according to CC.7.4. For each of the test points, perform the following steps.

Step 1:

- 1) Increase  $I_{EV\_target}$  by 20 A in a single step.

If this would result in an operating point which was outside of the operating range of the EV supply equipment or which would not allow for CCM any longer, then disregard this step and proceed with the next step.

- 2) Receive the next value of the acknowledged current request  $I_{Req\_ACK}$ .

The time of reception is  $t_0$ .

At  $t_0$ , measure  $I_{EVSE\_SideB}(t_0)$ .

- 3) Wait for  $T_{Transition\_max} = \max \left( 1 \text{ s}, \frac{|I_{Req\_ACK} - I_{EVSE\_SideB}(t_0)|}{20 \frac{\text{A}}{\text{s}}} \right)$  starting at  $t_0$ .

- 4) After  $T_{Transition\_max}$ , measure  $I_{EVSE\_SideB\_DC}$ ,  $I_{rip\_low}$ ,  $I_{rip\_mid}$  and  $I_{rip\_high}$ .

- 5) Perform calculations to be done for each test point  $TP_{m,n}$ .

- 6) Check if expected results are achieved.

- 7) Revert to the original test point.

Step 2:

- 1) Decrease  $I_{EV\_target}$  by 20 A in a single step.

If this would result in an operating point which was outside of the operating range of the EV supply equipment or which would not allow for CCM any longer, then disregard this step and proceed with the next step.

- 2) Receive the next value of the acknowledged current request  $I_{Req\_ACK}$ .

The time of reception is  $t_0$ .

At  $t_0$ , measure  $I_{EVSE\_SideB}(t_0)$ .

- 3) Wait for  $T_{Transition\_max} = \max \left( 1 \text{ s}, \frac{|I_{Req\_ACK} - I_{EVSE\_output}(t_0)|}{20 \frac{\text{A}}{\text{s}}} \right)$  starting at  $t_0$ .

- 4) After  $T_{Transition\_max}$ , measure  $I_{EVSE\_SideB\_DC}$ ,  $I_{rip\_low}$ ,  $I_{rip\_mid}$  and  $I_{rip\_high}$ .

- 5) Perform calculations to be done for each test point  $TP_{m,n}$ .

- 6) Check if expected results are achieved.

- 7) Revert to the original test point.

Step 3 – only applicable if ( $I_{EVSE\_intended\_m} < I_{EVSE\_max}$ ):

- 1) Increase  $I_{EV\_target}$  to  $I_{EVSE\_max}$  in a single step.

If this would result in an operating point which would not allow for CCM any longer, then disregard this step and proceed with the next step.

- 2) Receive the next value of the acknowledged current request  $I_{Req\_ACK}$ .

The time of reception is  $t_0$ .

At  $t_0$ , measure  $I_{EVSE\_SideB}(t_0)$ .

- 3) Wait for  $T_{Transition\_max} = \max \left( 1 \text{ s}, \frac{|I_{Req\_ACK} - I_{EVSE\_SideB}(t_0)|}{20 \frac{\text{A}}{\text{s}}} \right)$  starting at  $t_0$ .
- 4) After  $T_{Transition\_max}$ , measure  $I_{EVSE\_SideB\_DC}$ ,  $I_{rip\_low}$ ,  $I_{rip\_mid}$  and  $I_{rip\_high}$ .
- 5) Perform calculations to be done for each test point  $TP_{m,n}$ .
- 6) Check if expected results are achieved.
- 7) Revert to the original test point.

Step 4 – only applicable if ( $I_{EVSE\_intended\_m} > I_{EVSE\_min}$ ):

- 1) Decrease  $I_{EV\_target}$  to  $I_{EVSE\_min}$  in a single step.

If this would result in an operating point which would not allow for CCM any longer, then disregard this step and proceed with the next step.

- 2) Receive the next value of the acknowledged current request  $I_{Req\_ACK}$ .

The time of reception is  $t_0$ .

At  $t_0$ , measure  $I_{EVSE\_SideB}(t_0)$ .

- 3) Wait for  $T_{Transition\_max} = \max \left( 1 \text{ s}, \frac{|I_{Req\_ACK} - I_{EVSE\_SideB}(t_0)|}{20 \frac{\text{A}}{\text{s}}} \right)$  starting at  $t_0$ .
- 4) After  $T_{Transition\_max}$ , measure  $I_{EVSE\_SideB\_DC}$ ,  $I_{rip\_low}$ ,  $I_{rip\_mid}$  and  $I_{rip\_high}$ .
- 5) Perform calculations to be done for each test point  $TP_{m,n}$ .
- 6) Check if expected results are achieved.
- 7) Revert to the starting point.

#### CC.7.6.12.8 Expected results

This test case is passed if each of the following test criteria is fulfilled:

- for  $I_{EV\_target} \leq 5 \text{ A}$ :  
 $I_{dev\_abs} \leq 150 \text{ mA}$ ;
- for  $5 \text{ A} < I_{EV\_target} \leq 50 \text{ A}$ :  
 $I_{dev\_abs} \leq 1,5 \text{ A}$ ;
- for  $I_{EV\_target} > 50 \text{ A}$ :  
 $I_{dev\_rel} \leq 3 \%$ ;
- the current ripple shall meet the limits in Table CC.26.

**Table CC.26 – Current ripple limits**

	Current ripple, $A_{\text{peak-to-peak}}$		
	$I_{\text{EVSE\_SideB\_DC}} \leq 200 \text{ A}$	$200 \text{ A} < I_{\text{EVSE\_SideB\_DC}} \leq 400 \text{ A}$	$I_{\text{EVSE\_SideB\_DC}} > 400 \text{ A}$
$I_{\text{rip\_low}}$	$\leq 1,5$	$\leq (I_{\text{EVSE\_SideB\_DC}} \times 0,75 \%)$	$\leq (I_{\text{EVSE\_SideB\_DC}} \times 0,75 \%)$
$I_{\text{rip\_mid}}$	$\leq 6,0$	$\leq 6,0$	$\leq (I_{\text{EVSE\_SideB\_DC}} \times 1,5 \%)$
$I_{\text{rip\_high}}$	$\leq 9,0$	$\leq (I_{\text{EVSE\_SideB\_DC}} \times 4,5 \%)$	$\leq (I_{\text{EVSE\_SideB\_DC}} \times 4,5 \%)$

**CC.7.6.13 Insulation resistance checks before pre-charge (cable-check)****CC.7.6.13.1 Reference requirements**

This test case considers the following requirements:

- 6.3.1.113.3 Error shutdown;
- CC.4.1.2 Cable-check phase.

**CC.7.6.13.2 Description**

Reaction on low insulation resistance condition.

**CC.7.6.13.3 Test setup**

Standard test setup.

The insulation resistance of the EV simulator, between DC+ and PE and between DC– and PE, shall have an impedance sufficient to achieve the test resistances specified below. Each rail, DC+ to PE and DC– to PE, shall have an impedance of 5 M $\Omega$ , prior to adding any test resistance.

Symmetrical test

- Case 1: Two test resistors  $R_{\text{T}5} = R_{\text{T}6} = 300_{+2\%}^0 \text{ k}\Omega$ .
- Case 2: Two test resistors  $R_{\text{T}5} = R_{\text{T}6} = 100_{+2\%}^0 \text{ k}\Omega$ .

Asymmetrical test:

- Case 3: Test resistor  $R_{\text{T}5} = 150_{+2\%}^0 \text{ k}\Omega$ .
- Case 4: Test resistor  $R_{\text{T}6} = 150_{+2\%}^0 \text{ k}\Omega$ .
- Case 5: Test resistor  $R_{\text{T}5} = 100_{+2\%}^0 \text{ k}\Omega$ .
- Case 6: Test resistor  $R_{\text{T}6} = 100_{+2\%}^0 \text{ k}\Omega$ .

Disturbance test

- Case 7: Test resistors  $R_{\text{T}5} = R_{\text{T}6} = 150_{+2\%}^0 \text{ k}\Omega$ .
- Case 8: Test resistors  $R_{\text{T}5} = R_{\text{T}6} = 150_{+2\%}^0 \text{ k}\Omega$ .

- Case 9: Test resistors  $R_{T5} = R_{T6} = 150_{+2\%}^0$  k $\Omega$  followed by  $R_{T6} = 100_{+2\%}^0$  k $\Omega$ .
- Case 10: Test resistors  $R_{T5} = R_{T6} = 150_{+2\%}^0$  k $\Omega$  followed by  $R_{T5} = 100_{+2\%}^0$  k $\Omega$ .
- Case 11: Test resistors  $R_{T5} = R_{T6} = 150_{+2\%}^0$  k $\Omega$  followed by  $R_{T5} = R_{T6} = 100_{+2\%}^0$  k $\Omega$ .

During these tests, the Y-capacitance value for the test load of the EV simulator shall be  $C_{T7} = C_{T8} = 2$   $\mu$ F with  $S_{T24}$  and  $S_{T25}$  closed and for the EV supply equipment shall be worst case as defined by the EV supply equipment manufacturer.

#### CC.7.6.13.4 Preconditions

IMD according to CC.4.1.

#### CC.7.6.13.5 Definitions and calculations

None.

#### CC.7.6.13.6 Actions

Symmetric

Case 1:

- 1) The normal startup sequence shall be executed until  $t = t_4$  (according to Figure CC.5).
- 2) The EV simulator shall send a cable check request ("CableCheckReq").
- 3) Verify that  $V_{T8}$  is according to CC.4.1.2.

NOTE 1 If  $V_{T8}$  does not meet the requirements in CC.4.1.2, this is considered a noncompliance.

- 4) Close  $S_{T11}$  and  $S_{T13}$ .
- 5) Continue until  $t = t_6$ .

Case 2:

- 1) The normal startup sequence shall be executed until  $t = t_4$  (according to Figure CC.5).
- 2) The EV simulator shall send a cable-check request ("CableCheckReq").
- 3) Verify that  $V_{T8}$  is according to CC.4.1.2.

NOTE 2 If  $V_{T8}$  does not meet the requirements in CC.4.1.2, this is considered a noncompliance.

- 4) Close  $S_{T11}$  and  $S_{T13}$ .
- 5) Continue until  $t = t_6$ .

Asymmetric

Case 3:

- 1) The normal startup sequence shall be executed  $t = t_4$  (according to Figure CC.5).
- 2) The EV simulator shall send a cable-check request ("CableCheckReq").
- 3) Verify that  $V_{T8}$  is according to CC.4.1.2.

NOTE 3 If  $V_{T8}$  does not meet the requirements in CC.4.1.2, this is considered a noncompliance.

- 4) Close  $S_{T11}$ .
- 5) Continue until  $t = t_6$ .

**Case 4:**

- 1) The normal startup sequence shall be executed until  $t = t_4$  (according to Figure CC.5).
- 2) The EV simulator shall send a cable-check request ("CableCheckReq").
- 3) Verify that  $V_{T8}$  is according to CC.4.1.2.

NOTE 4 If  $V_{T8}$  does not meet the requirements in CC.4.1.2, this is considered a noncompliance.

- 4) Close  $S_{T13}$ .
- 5) Continue until  $t = t_6$ .

**Case 5:**

- 1) The normal startup sequence shall be executed until  $t = t_4$  (according to Figure CC.5).
- 2) The EV simulator shall send a cable-check request ("CableCheckReq").
- 3) Verify that  $V_{T8}$  is according to CC.4.1.2.

NOTE 5 If  $V_{T8}$  does not meet the requirements in CC.4.1.2, this is considered a noncompliance.

- 4) Close  $S_{T11}$ .
- 5) Continue until  $t = t_6$ .

**Case 6:**

- 1) The normal startup sequence shall be executed until  $t = t_4$  (according to Figure CC.5).
- 2) The EV simulator shall send a cable-check request ("CableCheckReq").
- 3) Verify that  $V_{T8}$  is according to CC.4.1.2.

NOTE 6 If  $V_{T8}$  does not meet the requirements in CC.4.1.2, this is considered a noncompliance.

- 4) Close  $S_{T13}$ .
- 5) Continue until  $t = t_6$ .

**Disturbance tests****Case 7 – long-term disturbance:**

- 1) The normal startup sequence shall be executed until  $t = t_4$  (according to Figure CC.5).
- 2) The EV simulator shall send a cable-check request ("CableCheckReq").
- 3) Verify that  $V_{T8}$  is according to CC.4.1.2.

NOTE 7 If  $V_{T8}$  does not meet the requirements in CC.4.1.2, this is considered a noncompliance.

- 4) Introduce resistance values by continuously alternating:
  - Close  $S_{T13}$  for 1 s.
  - Close  $S_{T11}$  for 1 s.
  - Maintain  $S_{T11}$  and  $S_{T13}$  open for 1 s.
- 5) Continue until  $t = t_6$ .

**Case 8 – short-term disturbance without insulation fault:**

- 1) The normal startup sequence shall be executed until  $t = t_4$  (according to Figure CC.5).
- 2) The EV simulator shall send a cable-check request ("CableCheckReq").
- 3) Verify that  $V_{T8}$  is according to CC.4.1.2.

NOTE 8 If  $V_{T8}$  does not meet the requirements in CC.4.1.2, this is considered a noncompliance.

4) Introduce resistance values by continuously alternating for 6 s:

- Close  $S_{T13}$  for 1 s.
- Close  $S_{T11}$  for 1 s.
- Maintain  $S_{T11}$  and  $S_{T13}$  open for 1 s.

5) Open  $S_{T11}$  and  $S_{T13}$ .

6) Continue until  $t = t_6$ .

Case 9 – short-term disturbance with insulation fault:

1) The normal startup sequence shall be executed until  $t = t_4$  (according to Figure CC.5).

2) The EV simulator shall send a cable-check request ("CableCheckReq").

3) Verify that  $V_{T8}$  is according to CC.4.1.2.

NOTE 9 If  $V_{T8}$  does not meet the requirements in CC.4.1.2, this is considered a noncompliance.

4) Introduce resistance values by continuously alternating for 6 s:

- Close  $S_{T13}$  for 1 s.
- Close  $S_{T11}$  for 1 s.
- Maintain  $S_{T11}$  and  $S_{T13}$  open for 1 s.

5) Open  $S_{T11}$  and  $S_{T13}$ .

6) Change  $R_{T6}$  to  $100^{0}_{+2}\%$  k $\Omega$  and close  $S_{T13}$  after 6 s.

7) Continue until  $t = t_6$ .

Case 10 – short-term disturbance with insulation fault:

1) The normal startup sequence shall be executed until  $t = t_4$  (according to Figure CC.5).

2) The EV simulator shall send a cable-check request ("CableCheckReq").

3) Verify that  $V_{T8}$  is according to CC.4.1.2.

NOTE 10 If  $V_{T8}$  does not meet the requirements in CC.4.1.2, this is considered a noncompliance.

4) Introduce resistance values by continuously alternating for 6 s:

- Close  $S_{T13}$  for 1 s.
- Close  $S_{T11}$  for 1 s.
- Maintain  $S_{T11}$  and  $S_{T13}$  open for 1 s.

5) Open  $S_{T11}$  and  $S_{T13}$ .

6) Change  $R_{T5}$  to  $100^{0}_{+2}\%$  k $\Omega$  and close  $S_{T11}$  after 6 s.

7) Continue until  $t = t_6$ .

Case 11 – short-term disturbance with insulation fault:

1) The normal startup sequence shall be executed until  $t = t_4$  (according to Figure CC.5).

2) The EV simulator shall send a cable-check request ("CableCheckReq").

3) Verify that  $V_{T8}$  is according to CC.4.1.2.

NOTE 11 If  $V_{T8}$  does not meet the requirements in CC.4.1.2, this is considered a noncompliance.

- 4) Introduce resistance values by continuously alternating for 6 s:
  - Close  $S_{T13}$  for 1 s.
  - Close  $S_{T11}$  for 1 s.
  - Maintain  $S_{T11}$  and  $S_{T13}$  open for 1 s.
- 5) Open  $S_{T11}$  and  $S_{T13}$ .
- 6) Change  $R_{T5}$  and  $R_{T6}$  to  $100^{0}_{+2\%}$  k $\Omega$  and close  $S_{T11}$  and  $S_{T13}$  after 6 s.
- 7) Continue until  $t = t_6$ .

Cases 2, 5 and 6 shall be repeated five times with  $S_{T12}$  and  $S_{T14}$  closed and with an additional  $C_{T1}$  and  $C_{T2}$  with capacitance values of 2,5  $\mu$ F, 5  $\mu$ F, 10  $\mu$ F, 15  $\mu$ F and 25  $\mu$ F.

NOTE 12 The fact that the test incorporates higher capacitance values than specified in ISO 17409 and ISO 5474 does not indicate those values are acceptable in the design of the EV.

#### CC.7.6.13.7 Expected results

For all cases:

The present voltage at side B requirements specified in CC.4.1.2 shall be met.

For cases 1, 3, 4, and 8:

The EV supply equipment shall complete the cable-check by sending last cable-check response message with "EVSEIsolationStatus" = 'Valid' and "EVSEProcessing" = 'Finished'.

For cases 2, 5, 6, 7, 9, 10 and 11:

- The EV supply equipment shall send a "CableCheckRes" <4b> message with "EVSEIsolationStatus" = 'Fault'.
- Latest at  $t = t_6$ , the EV supply equipment shall trigger an error shutdown and thus shall
  - reduce its present current at side B to < 5 A DC and disable its side B in 1 s or less,
  - reduce its present voltage at side B to < 60 V DC between DC+ and DC– in 2,5 s or less, and
  - maintain the control circuit supply voltage  $U_{CC}$  between the specified range that allows normal operation of the control circuit.

For testing the IMD under excessive Y-capacitance:

For cases 2, 5 and 6 with an additional  $C_{T1}$  and  $C_{T2}$  with capacitance values of 2,5  $\mu$ F, 5  $\mu$ F, 10  $\mu$ F, 15  $\mu$ F and 25  $\mu$ F:

- The EV supply equipment shall send "CableCheckRes" <4a> message with "EVSEIsolationStatus" = 'Fault'.
- Latest at  $t = t_6$ , the EV supply equipment shall trigger an error shutdown and thus shall
  - reduce its present current at side B to < 5 A DC and disable its side B in 1 s or less,
  - reduce its present voltage at side B to < 60 V DC between DC+ and DC– in 2,5 s or less, and
  - maintain the control circuit supply voltage  $V_S1$  between the specified range that allows normal operation of the control circuit.

## CC.7.6.14 Insulation resistance check to detect fault state during energy transfer

### CC.7.6.14.1 Reference requirements

This test case considers the following requirements:

- 6.3.1.108 Control circuit supply integrity;
- 6.3.1.113.3 Error shutdown;
- CC.4.1.6 Insulation monitoring after the cable-check phase.

### CC.7.6.14.2 Description

Test the reaction on a low insulation resistance condition ( $R \leq 100 \Omega/V$ ) during the energy transfer phase.

The EV supply equipment shall trigger an error shutdown.

### CC.7.6.14.3 Test setup

Standard test setup.

The insulation resistance of the EV simulator, between DC+ and PE and between DC– and PE, shall have an impedance sufficient to achieve the test resistances shown below. Each rail, DC+ to PE and DC– to PE, shall have an impedance of 5 M $\Omega$ , prior to adding any test resistance.

Symmetrical test:

- Case 1: Two test resistors  $R_{T5} = R_{T6} = 300_{+2\%}^0 \text{ k}\Omega$ .
- Case 2: Two test resistors  $R_{T5} = R_{T6} = 100_{+2\%}^0 \text{ k}\Omega$ .

Asymmetrical test:

- Case 3: Test resistor  $R_{T5} = 150_{+2\%}^0 \text{ k}\Omega$ .
- Case 4: Test resistor  $R_{T6} = 150_{+2\%}^0 \text{ k}\Omega$ .
- Case 5: Test resistor  $R_{T5} = 100_{+2\%}^0 \text{ k}\Omega$ .
- Case 6: Test resistor  $R_{T6} = 100_{+2\%}^0 \text{ k}\Omega$ .

Disturbance test:

- Case 7: Two test resistors  $R_{T5} = R_{T6} = 150_{+2\%}^0 \text{ k}\Omega$ .
- Case 8: Two test resistors  $R_{T5} = R_{T6} = 150_{+2\%}^0 \text{ k}\Omega$ .
- Case 9: Two test resistors  $R_{T5} = R_{T6} = 150_{+2\%}^0 \text{ k}\Omega$  followed by  $R_{T6} = 100_{+2\%}^0 \text{ k}\Omega$ .
- Case 10: Two test resistor  $R_{T5} = R_{T6} = 150_{+2\%}^0 \text{ k}\Omega$  followed by  $R_{T5} = 100_{+2\%}^0 \text{ k}\Omega$ .
- Case 11: Two test resistors  $R_{T5} = R_{T6} = 150_{+2\%}^0 \text{ k}\Omega$  followed by  $R_{T5} = R_{T6} = 100_{+2\%}^0 \text{ k}\Omega$ .

During these tests, the Y-capacitance value for the EV simulator shall be  $C_{T7} = C_{T8} = 2 \mu\text{F}$  with  $S_{T24}$  and  $S_{T25}$  closed and for the EV supply equipment shall be the worst case as defined by the EV supply equipment manufacturer.

#### **CC.7.6.14.4 Preconditions**

IMD according CC.4.1.

#### **CC.7.6.14.5 Definitions and calculations**

None.

#### **CC.7.6.14.6 Actions**

Symmetric tests

Case 1:

- 1) Start FPT until reaching OP5 and then introduce resistance values as indicated below.
- 2) Close  $S_{T11}$  and  $S_{T13}$ . Continue FPT for 1 min.
- 3) FPT shall not stop during that 1 min duration.

Case 2:

- 1) Start FPT until reaching OP5 and then introduce resistance values as indicated below.
- 2) Close  $S_{T11}$  and  $S_{T13}$ . Attempt FPT for 1 min.
- 3) The EV supply equipment shall trigger an error shutdown in 10 s or less and the error shutdown shall be executed.

Asymmetric tests

Case 3:

- 1) Start FPT until reaching OP5 and then introduce resistance values as indicated below.
- 2) Close  $S_{T11}$ . Continue FPT for 1 min.
- 3) FPT shall not stop during that 1 min duration.

Case 4:

- 1) Start FPT until OP5 and then introduce resistance values as indicated below.
- 2) Close  $S_{T13}$ . Continue FPT for 1 min.
- 3) FPT shall not stop during that 1 min duration.

Case 5:

- 1) Start FPT until reaching OP5 and then introduce resistance values as indicated below.
- 2) Close  $S_{T11}$ . Attempt FPT for 1 min.
- 3) The EV supply equipment shall trigger an error shutdown in 10 s or less and the error shutdown shall be executed.

Case 6:

- 1) Start FPT until reaching OP5 and then introduce resistance values as indicated below.
- 2) Close  $S_{T13}$ . Attempt FPT for 1 min.

- 3) The EV supply equipment shall trigger an error shutdown in 10 s or less and the error shutdown shall be executed.

#### Disturbance tests

##### Case 7 – long-term disturbance:

- 1) Start FPT until reaching OP5 and then introduce resistance values as indicated below.
- 2) Continuously alternate:
  - Close S<sub>T</sub>13 for 1 s.
  - Close S<sub>T</sub>11 for 1 s.
  - Maintain S<sub>T</sub>11 and S<sub>T</sub>13 open for 1 s.
- 3) Attempt FPT for 1 min.
- 4) The EV supply equipment shall trigger an error shutdown in 30 s or less and the error shutdown shall be executed.

##### Case 8 – short-term disturbance without insulation fault:

- 1) Start FPT until reaching OP5 and then introduce resistance values as indicated below.
- 2) Continuously alternate for 6 s:
  - Close S<sub>T</sub>13 for 1 s.
  - Close S<sub>T</sub>11 for 1 s.
  - Maintain S<sub>T</sub>11 and S<sub>T</sub>13 open for 1 s.
  - Open S<sub>T</sub>11 and S<sub>T</sub>13.
- 3) Continue FPT for 1 min.
- 4) FPT shall not stop during that 1 min duration.

##### Case 9 – short-term disturbance with insulation fault:

- 1) Start FPT until reaching OP5 and then introduce resistance values as indicated below.
- 2) Continuously alternate for 6 s:
  - Close S<sub>T</sub>13 for 1 s.
  - Close S<sub>T</sub>11 for 1 s.
  - Maintain S<sub>T</sub>11 and S<sub>T</sub>13 open for 1 s.
- 3) Open S<sub>T</sub>11 and S<sub>T</sub>13.
- 4) Change R<sub>T</sub>6 to 100<sup>0</sup><sub>+2%</sub> kΩ and close S<sub>T</sub>13 after 6 s and attempt FPT for 1 min.
- 5) The EV supply equipment shall trigger an error shutdown 10 s after inserting the fault resistance of 100 kΩ. The error shutdown shall be executed.

##### Case 10 – short-term disturbance with insulation fault:

- 1) Start FPT until reaching OP5 and then introduce resistance values as indicated below.
- 2) Continuously alternate for 6 s:
  - Close S<sub>T</sub>13 for 1 s.
  - Close S<sub>T</sub>11 for 1 s.
  - Maintain S<sub>T</sub>11 and S<sub>T</sub>13 open for 1 s.
- 3) Open S<sub>T</sub>11 and S<sub>T</sub>13.

- 4) Change  $R_{T5}$  to  $100^{0}_{+2\%}$  k $\Omega$  and close  $S_{T11}$  after 6 s and attempt FPT for 1 min.
- 5) The EV supply equipment shall trigger an error shutdown 10 s after inserting the fault resistance of 100 k $\Omega$ . The error shutdown shall be executed.

Case 11 – short-term disturbance with insulation fault:

- 1) Start FPT until reaching OP5 and then introduce resistance values as indicated below.
- 2) Continuously alternate for 6 s:
  - Close  $S_{T13}$  for 1 s.
  - Close  $S_{T11}$  for 1 s.
  - Maintain  $S_{T11}$  and  $S_{T13}$  open for 1 s.
- 3) Open  $S_{T11}$  and  $S_{T13}$ .
- 4) Change  $R_{T5}$  and  $R_{T6}$  to  $100^{0}_{+2\%}$  k $\Omega$  and close  $S_{T11}$  and  $S_{T13}$  after 6 s and attempt FPT for 1 min.
- 5) The EV supply equipment shall trigger an error shutdown after inserting the fault resistance of 100 k $\Omega$ . The error shutdown shall be executed.

Cases 2, 5 and 6 shall be repeated five times with  $S_{T12}$  and  $S_{T14}$  closed and with an additional  $C_{T1}$  and  $C_{T2}$  with capacitance values of 2,5 uF, 5 uF, 10 uF, 15 uF, 25 uF.

NOTE The fact that the test incorporates higher capacitance values than specified in ISO 17409 and ISO 5474 does not indicate those values are acceptable in the design of the EV.

#### CC.7.6.14.7 Expected results

For cases 1, 3, 4, and 8:

The EV supply equipment shall continue FPT.

For cases 2, 5, 6, 7, 9, 10 and 11:

- The EV supply equipment shall reduce the present current at side B and shall reduce the present current at side B to < 5 A and disable its side B in 11 s or less (31 s or less for case 7) after injection of the fault.
- The EV supply equipment shall send parameter "ResponseCode" = 'FAILED' and "EVSEIsolationStatus" = 'Fault' in at least one of the CurrentDemandRes response messages in 11,5 s or less (31,5 s or less for case 7) after injection of the fault. See IEC 61851-24:2023.
- The EV supply equipment shall start to reduce the present voltage at side B and shall reduce the present voltage at side B to < 60 V DC between DC+ and DC– in 12,5 s or less (32,5 s or less for case 7) after injection of the fault.
- The control circuit supply voltage  $V_{s1}$  shall remain within the specified range that allows normal operation of the control circuit.

For testing the IMD under excessive Y-capacitance:

For cases 2, 5 and 6 with an additional  $C_{T1}$  and  $C_{T2}$  with capacitance values of 2,5 uF, 5 uF, 10 uF, 15 uF and 25 uF:

- The EV supply equipment shall start to reduce the present current at side B and shall reduce the present current at side B to < 5 A and disable its side B in 11 s or less after injection of the fault.

- The EV supply equipment shall send parameter "ResponseCode" = 'FAILED' and "EVSEIsolationStatus" = 'Fault' in at least one of the CurrentDemandRes response messages in 11,5 s or less after injection of the fault. See IEC 61851-24:2023.
- The EV supply equipment shall start to reduce the present voltage at side B and shall reduce the present voltage at side B to < 60 V between DC+ and DC– in 12,5 s or less after injection of the fault.
- The control circuit supply voltage  $V_{S1}$  shall remain within the specified range that allows normal operation of the control circuit.

#### **CC.7.6.15 Short-circuit between the control pilot conductor and the protective conductor**

##### **CC.7.6.15.1 Reference requirements**

This test case considers the following requirements:

- CC.4.3 Loss of electrical continuity of the control pilot conductor;
- 6.3.1.113.4 Emergency shutdown.

##### **CC.7.6.15.2 Description**

Check if the EV supply equipment will perform an emergency shutdown in case of a short-circuit between CP and PE.

##### **CC.7.6.15.3 Test setup**

Standard test setup.

##### **CC.7.6.15.4 Preconditions**

None.

##### **CC.7.6.15.5 Definitions and calculations**

Definition of intended test point:

TP = ( $I_{EVSE\ intended} / V_{EVSE\ intended}$ ) with:

- $I_{EVSE\ intended} = I_{EVSE\ max}$
- $V_{EVSE\ intended} = V_{EVSE\ min}$
- TP equals to OP5.

##### **CC.7.6.15.6 Actions**

- 1) Approach the test point according to CC.7.4.
- 2) Close  $S_{T6}$ .
- 3) Check if expected results are achieved.

##### **CC.7.6.15.7 Expected results**

The EV supply equipment shall perform an emergency shutdown. That means that the EV supply equipment shall

- turn off its CP oscillator to indicate an emergency shutdown in 20 ms or less after closing  $S_{T6}$ ,
- reduce the present current at side B to  $\leq 5$  A DC and disable its side B in 30 ms or less after closing  $S_{T6}$ ,

- reduce the present voltage at side B to  $\leq 60$  V DC between DC+ and DC– in 1 010 ms or less after closing S<sub>T6</sub>, and
- reduce the present voltage at side B to  $\leq 60$  V DC between DC+ and the protective conductor, and between DC– and the protective conductor in 1 010 ms or less after closing S<sub>T6</sub>

**CC.7.6.16 Short-circuit protection during energy transfer and control circuit supply integrity**

**CC.7.6.16.1 Reference requirements**

This test case considers the following requirements:

- 6.3.1.108 Control circuit supply integrity;
- 13.101 Short-circuit protection of the DC connection during energy transfer.

**CC.7.6.16.2 Description**

Reaction on overcurrent condition caused by external or internal faults.

**CC.7.6.16.3 Test setup**

Standard test setup with the values specified in Table CC.27:

**Table CC.27 – EV simulator characteristics**

	Equivalent resistance R <sub>T2</sub>	Equivalent inductance L <sub>T1</sub>
Configuration 1	10 mΩ ± 15 %	0,5 μH ≤ L <sub>T1</sub> ≤ 3 μH
Configuration 2	100 mΩ ± 10 %	2 μH ≤ L <sub>T1</sub> ≤ 5 μH
Configuration 3	250 mΩ ± 10 %	2 μH ≤ L <sub>T1</sub> ≤ 7 μH

R<sub>T2</sub> is the equivalent resistance of the short-circuit loop of the EV simulator. R<sub>T2</sub> shall be measured between DC+ and DC– of the EV simulator vehicle inlet at a frequency of  $f_{meas} = 1$  kHz (EV simulator un-mated).

L<sub>T1</sub> is the equivalent inductance of the short-circuit loop of the EV simulator. L<sub>T1</sub> shall be measured between the DC+ and DC– contact of the EV simulator vehicle inlet at a frequency of  $f_{meas} = 1$  kHz (EV simulator un-mated).

During this test, S<sub>T7</sub> shall remain open.

The bandwidth of the current and voltage measurement shall be  $\geq 500$  kHz.

Contact bouncing of the switching device S<sub>T8</sub> shall be avoided by selecting an appropriate switching device.

NOTE R<sub>T2</sub> and L<sub>T1</sub> represent different short-circuit conditions (caused by different HV wiring lengths, different short-circuit resistances, etc.).

**CC.7.6.16.4 Preconditions**

None.

**CC.7.6.16.5 Definitions and calculations**

Definition of intended test points:

TP1 = ( $I_{EVSE\ intended\ 1}$  /  $V_{EVSE\ intended\ 1}$ ) with:

- $I_{EVSE\ intended\ 1} = I_{EVSE\ max}$
- $V_{EVSE\ intended\ 1} = P_{EVSE\ max} / I_{EVSE\ max}$
- TP1 equals to OP4.

TP2 = ( $I_{EVSE\ intended\ 2}$  /  $V_{EVSE\ intended\ 2}$ ) with:

- $I_{EVSE\ intended\ 2} = P_{EVSE\ max} / V_{EVSE\ max}$
- $V_{EVSE\ intended\ 2} = V_{EVSE\ max}$
- TP2 equals to OP3.

Target values requested to approach test point:

- $I_{EV\ target\ m} = I_{EVSE\ intended\ m}$
- $V_{EV\ target} = V_{EVSE\ max}$  (to allow for CCM)

Calculations:

Determine

$$\sum_n i_n^2 \Delta t_{sample}$$

from the point in time when switch S<sub>T</sub>8 is closed until the point in time when the EV supply equipment has shut down.

**CC.7.6.16.6 Actions**

The main actions to be performed for all test points are as follows.

- 1) For each test point TP, conduct three single tests using the configurations 1, 2 and 3 of the EV simulator as specified in the test setup.
- 2) Approach the test point according to CC.7.4.
- 3) Close S<sub>T</sub>8.
- 4) Measure and log A<sub>T</sub>1 and V<sub>T</sub>8 from the point in time when S<sub>T</sub>8 is closed until the point in time when the EV supply equipment performed the emergency shutdown.
- 5) Open S<sub>T</sub>8.
- 6) Check if the expected results are achieved.

**CC.7.6.16.7 Expected results**

The EV supply equipment shall comply with the following.

- Short-circuit peak current ≤ 10 kA.
- $\sum_n i_n^2 \Delta t_{sample} \leq 1\,000\,000\ A^2s$ .

- The EV supply equipment shall perform an emergency shutdown. That means that the EV supply equipment shall
  - turn off its CP oscillator to indicate an emergency shutdown in 1 010 ms or less after closing  $S_{T8}$ ,
  - reduce the present current at side B to  $\leq 5$  A DC and disable its side B in 1 020 ms or less after closing  $S_{T8}$ ,
  - reduce the present voltage at side B to  $\leq 60$  V DC between DC+ and DC– in 2 000 ms or less after closing  $S_{T8}$ , and
  - reduce the present voltage at side B to  $\leq 60$  V DC between DC+ and the protective conductor, and between DC– and the protective conductor in 2 000 ms or less after closing  $S_{T8}$ .
- The control circuit supply voltage  $V_{S1}$  shall remain within the specified range that allows normal operation of the control circuit.

**CC.7.6.17 Test of measured voltage values during welding detection**

**CC.7.6.17.1 General**

The test point matrix for the compliance test is shown in Figure CC.34.

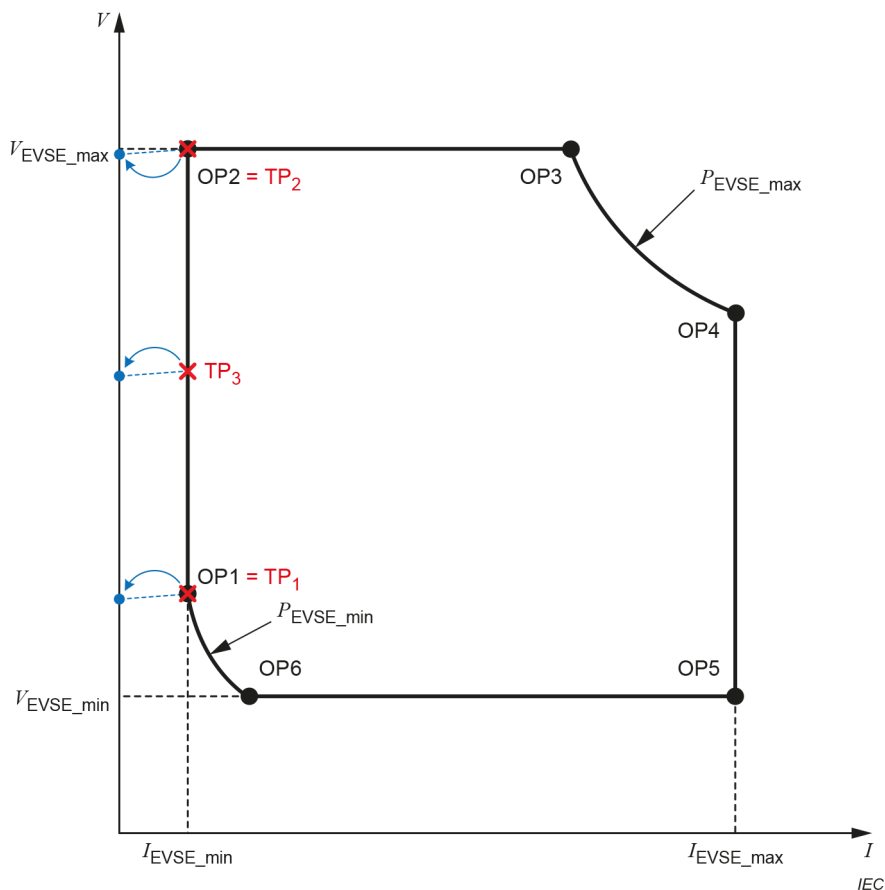

**Figure CC.34 – Test points for voltage measurement during welding detection**

**CC.7.6.17.2 Reference requirements**

This test case considers the following requirements:

- Table CC.9 – Sequence description for normal shutdown (t106 ► t107);
- CC.6.3 Measuring current and voltage.

**CC.7.6.17.3 Description**

Check if the voltage values measured by the EV supply equipment and transferred via digital communication are correct.

**CC.7.6.17.4 Test setup**

Standard test setup.

**CC.7.6.17.5 Preconditions**

None.

**CC.7.6.17.6 Definitions and calculations**

Definition of test points TP<sub>n</sub>:

- TP<sub>1</sub> = ( $I_{EVSE\_intended\_1}$  /  $V_{EVSE\_intended\_1}$ ) with:
  - $I_{EVSE\_intended\_1} = I_{EVSE\_min}$ ;
  - $V_{EVSE\_intended\_1} = \max(P_{EVSE\_min} / I_{EVSE\_min}; V_{EVSE\_min})$ ;
  - TP<sub>1</sub> is equal to OP<sub>1</sub>.
- TP<sub>2</sub> = ( $I_{EVSE\_intended\_2}$  /  $V_{EVSE\_intended\_2}$ ) with:
  - $I_{EVSE\_intended\_2} = I_{EVSE\_min}$ ;
  - $V_{EVSE\_intended\_2} = V_{EVSE\_max}$ ;
  - TP<sub>2</sub> is equal to OP<sub>2</sub>.
- TP<sub>3</sub> = ( $I_{EVSE\_intended\_3}$  /  $V_{EVSE\_intended\_3}$ ) with:
  - $I_{EVSE\_intended\_3} = I_{EVSE\_min}$ ;
  - $V_{EVSE\_intended\_3} = V_{EVSE\_min} + (V_{EVSE\_max} - V_{EVSE\_min}) / 2$ .

Calculations:

- $V_{dev\_abs\ measure} = |V_{EVSE\_measure} - V_{EVSE\_SideB\_DC}|$  with:  
 $V_{EVSE\_measure}$  = "EVSEPresentVoltage" of the message "WeldingDetectionRes" <9b>

**CC.7.6.17.7 Actions**

Each of the test points shall be approached according to CC.7.4. For each of the test points, do the following steps.

- 1) Request target values with the following parameters in the message "CurrentDemandReq" <7a>:
  - EVTargetCurrent =  $I_{EV\_target} = 0$  A.
- 2) Once A<sub>T1</sub> is < 5 A, send message "PowerDeliveryReq" <8a> (see t102 in Figure CC.6) in order to request the EV supply equipment to disable its side B.
- 3) Wait until the EV supply equipment has disabled its side B and message "PowerDeliveryRes" <8b> with parameters:
  - EVSEStatusCode = EVSE\_Shutdown, or
  - EVSEStatusCode = EVSE\_UtilityInterruptEvent
 has been received (see t104 in Figure CC.6).
- 4) Change the CP state from C or D to B (see t105 in Figure CC.6).

- 5) Send message WeldingDetectionReq <9a> in order to read the present voltage at side B measured by the EV supply equipment in the WeldingDetectionRes <9b> message.
- 6) Receive parameter EVSEPresentVoltage in "WeldingDetectionRes" <9b> message.
- 7) Determine  $V_{\text{dev\_abs\_measure}}$ .
- 8) Check if expected results are achieved.

#### **CC.7.6.17.8 Expected results**

$V_{\text{dev\_abs\_measure}} \leq 10 \text{ V}$ .

### **CC.7.6.18 Normal shutdown by EV supply equipment**

#### **CC.7.6.18.1 Reference requirements**

This test case considers the following requirements:

- CC.3.3 Normal shutdown or pause after energy transfer.

#### **CC.7.6.18.2 Description**

Check if EV supply equipment performs a normal shutdown (according to Table CC.9) triggered by user interaction, for example, by pressing a stop button.

#### **CC.7.6.18.3 Test setup**

Standard test setup.

#### **CC.7.6.18.4 Preconditions**

None.

#### **CC.7.6.18.5 Definitions and calculations**

Definition of test point TP:

TP = ( $I_{\text{EVSE\_intended}}$  /  $V_{\text{EVSE\_intended}}$ ) with:

- $I_{\text{EVSE\_intended}} = I_{\text{EVSE max}}$ ;
- $V_{\text{EVSE\_intended}} = V_{\text{EVSE min}}$ ;
- TP is equal to OP5.

#### **CC.7.6.18.6 Actions**

The test point TP shall be approached according to CC.7.4. Then do the following steps.

- 1) Stop the communication session at the EV supply equipment, for example, by pressing the stop button.  
Check if expected results 1) and 2) are achieved.
- 2) Once  $A_{\text{T1}}$  is < 5 A, send message "PowerDeliveryReq" <8a> in order to request the EV supply equipment to disable its side B (see t102).
- 3) Open  $S_{\text{T17}}$  and  $S_{\text{T18}}$  of the test load (see Figure 132).  
Check if expected results 3) and 4) are achieved.
- 4) Change the CP state from C or D to B (see t105).

- 5) Send message "SessionStopReq" <10a> in order to terminate the communication session. If using ISO 15118-2:2014, use following parameter:
  - ChargingSession = Terminateto terminate digital communication (see t107).  
Check if expected results 5) and 6) are achieved.

#### **CC.7.6.18.7 Expected results**

- 1) The EV supply equipment shall:
  - ramp down  $A_T1$  to  $< 5$  A, and
  - adjust parameter "EVSEMaximumCurrentLimit" in the next "CurrentDemandRes" <7b> messages according to the present current at side B (see t100 ► t101).
- 2) Once  $A_T1$  is  $< 5$  A, the EV supply equipment shall set parameter
  - EVSEStatusCode = EVSE\_Shutdownin the next "CurrentDemandRes" <7b> message (see t101).
- 3) The EV supply equipment shall disable its side B and open the EV supply equipment disconnection device, if any. The EV supply equipment shall
  - reduce  $V_T8$  to  $\leq 60$  V in 2 s or less after  $S_T17$  and  $S_T18$  have been opened,
  - reduce  $V_T6$  and  $V_T7$  to  $\leq 60$  V in 2 s or less after  $S_T17$  and  $S_T18$  have been opened, and
  - disable the EVSE IMD (see t103).
- 4) Once expected results 3) have been achieved, the EV supply equipment shall communicate that the present current at side B is  $\leq 5$  A and has disabled its side B by sending message "PowerDeliveryRes" <8b> with following parameters (see t104):
  - EVSEStatusCode = EVSE\_Shutdown.
- 5) The EV supply equipment shall reduce and maintain the present voltage at side B  $\leq 60$  V in 1 s or less after message "SessionStopReq" <10a> has been received and acknowledged by the EV supply equipment (see t107 ► t108).
- 6) Once expected results 5) have been achieved, the EV supply equipment shall send message "SessionStopRes" <10b> (see t108).
  - If using ISO 15118-2:2014 the EV supply equipment shall turn off its CP oscillator.
  - If using DIN SPEC 70121:2014 the EV supply equipment shall turn off its CP oscillator 1,5 s after sending message "SessionStopRes" <10b>.

#### **CC.7.6.19 Normal shutdown by EV**

##### **CC.7.6.19.1 Reference requirements**

This test case considers the following requirements:

- CC.3.3 Normal shutdown or pause after energy transfer.

##### **CC.7.6.19.2 Description**

Check if the EV supply equipment performs a normal shutdown (according Table CC.7) triggered by the EV.

##### **CC.7.6.19.3 Test setup**

Standard test setup.

##### **CC.7.6.19.4 Preconditions**

None.

### CC.7.6.19.5 Definitions and calculations

TP = ( $I_{EVSE\_intended} / V_{EVSE\_intended}$ ) with:

- $I_{EVSE\_intended} = I_{EVSE\ max}$ ;
- $V_{EVSE\_intended} = V_{EVSE\ min}$ ;
- TP is equal to OP5.

### CC.7.6.19.6 Actions

The test point TP shall be approached according to CC.7.4. Then do the following steps.

- 1) Request the termination of energy transfer with the following parameter in the message "CurrentDemandReq" <7a> in order to simulate a communication session stop triggered by the EV:
  - EVTargetCurrent = 0 A.
 Check if expected results 1) are achieved.
- 2) Once  $A_{T1}$  is < 5 A, send message "PowerDeliveryReq" <8a> in order to request the EV supply equipment to disable its side B (see t102).
- 3) Open  $S_{T17}$  and  $S_{T18}$  (see Figure 132).
  - Check if expected results 2) and 3) are achieved.
- 4) Change the CP state from C or D to B (see t105).
- 5) Send message "SessionStopReq" <10a> in order to terminate the communication session. If using ISO 15118-2:2014, use following parameter:
  - ChargingSession = Terminate
 to terminate digital communication (see t107).
  - Check if expected results 4) and 5) are achieved.

### CC.7.6.19.7 Expected results

- 1) The EV supply equipment shall
  - ramp down  $A_{T1}$  to < 5 A.
- 2) The EV supply equipment shall disable its side B and open the EV supply equipment disconnection device, if any. The EV supply equipment shall:
  - reduce  $V_{T8} \leq 60$  V in 2 s or less after  $S_{T17}$  and  $S_{T18}$  have been opened,
  - reduce  $V_{T6}$  and  $V_{T7}$  to  $\leq 60$  V in 2 s or less after  $S_{T17}$  and  $S_{T18}$  have been opened, and
  - disable the EVSE IMD (see t103).
- 3) Once expected results 2) have been achieved, the EV supply equipment shall communicate that the present current at side B is  $\leq 5$  A and has disabled its side B by sending message "PowerDeliveryRes" <8b> with following parameters (see t104):
  - EVSEStatusCode = EVSE\_Shutdown.
- 4) The EV supply equipment shall reduce and maintain the present voltage at side B  $\leq 60$  V in 1 s or less after message "SessionStopReq" <10a> has been received and acknowledged by the EV supply equipment (see t107 ► t108).
- 5) Once expected results 4) have been achieved, the EV supply equipment shall send message "SessionStopRes" <10b> (see t108).
  - If using ISO 15118-2:2014, the EV supply equipment shall turn off its CP oscillator.
  - If using DIN SPEC 70121:2014, the EV supply equipment shall turn off its CP oscillator 1,5 s after sending message "SessionStopRes" <10b>.

## **CC.7.6.20 Short-circuit check before energy transfer**

### **CC.7.6.20.1 Reference requirements**

This test case considers the following requirements:

- 6.3.1.109 Short-circuit check before energy transfer;
- 6.3.1.113.3 Error shutdown.

### **CC.7.6.20.2 Description**

Reaction on short-circuit between DC+ and DC– before energy transfer.

### **CC.7.6.20.3 Test setup**

Standard test setup with  $R_{T2} = 100 \Omega \pm 10 \%$  (equivalent resistance of the short-circuit loop) and  $L_{T1} = 0$  mH.

### **CC.7.6.20.4 Preconditions**

The EV supply equipment has successfully communicated its following properties to the EV simulator:

- $V_{EVSE\_min}$ ;
- $V_{EVSE\_max}$ ;
- $I_{EVSE\_min}$ ;
- $I_{EVSE\_max}$ ;
- $P_{EVSE\_max}$ .

The FPT sequence shall be successfully done until  $t = t_4$  according to Figure CC.5.

### **CC.7.6.20.5 Definitions and calculations**

None.

### **CC.7.6.20.6 Actions**

The test case shall be executed in single steps as indicated below:

- 1) Close  $S_{T8}$ .
- 2) The EV simulator shall perform the insulation resistance check (that is, send "CableCheckReq").

### **CC.7.6.20.7 Expected results**

The EV supply equipment shall perform an error shutdown.

- The EVSE shall reduce its present current at side B to  $< 5$  A and disable its side B in 1 s or less.
- The EVSE shall, in 2,5 s or less,
  - reduce the present voltage at side B to  $< 60$  V between DC+ and DC–, and
  - reduce the present voltage at side B to  $< 60$  V between DC+ and the protective conductor, and between DC– and the protective conductor.
- The EV supply equipment shall turn off the CP oscillator.

### **CC.7.6.21 Functional check of the insulation monitoring device**

#### **CC.7.6.21.1 Reference requirements**

This test case considers the following requirements:

- CC.4.1.3 Functional check of the insulation monitoring device.

#### **CC.7.6.21.2 Description**

Test of the functional check of the IMD.

The following tests shall be performed to signal an interruption of the measurement connections to the side B live parts (DC+/DC–) and the protective conductor.

#### **CC.7.6.21.3 Test setup**

The standard test setup, shown in Figure CC.35 (simplified diagram), includes additional means to interrupt the IMD measurement connections to the side B live parts (DC+/DC–) and the protective conductor.

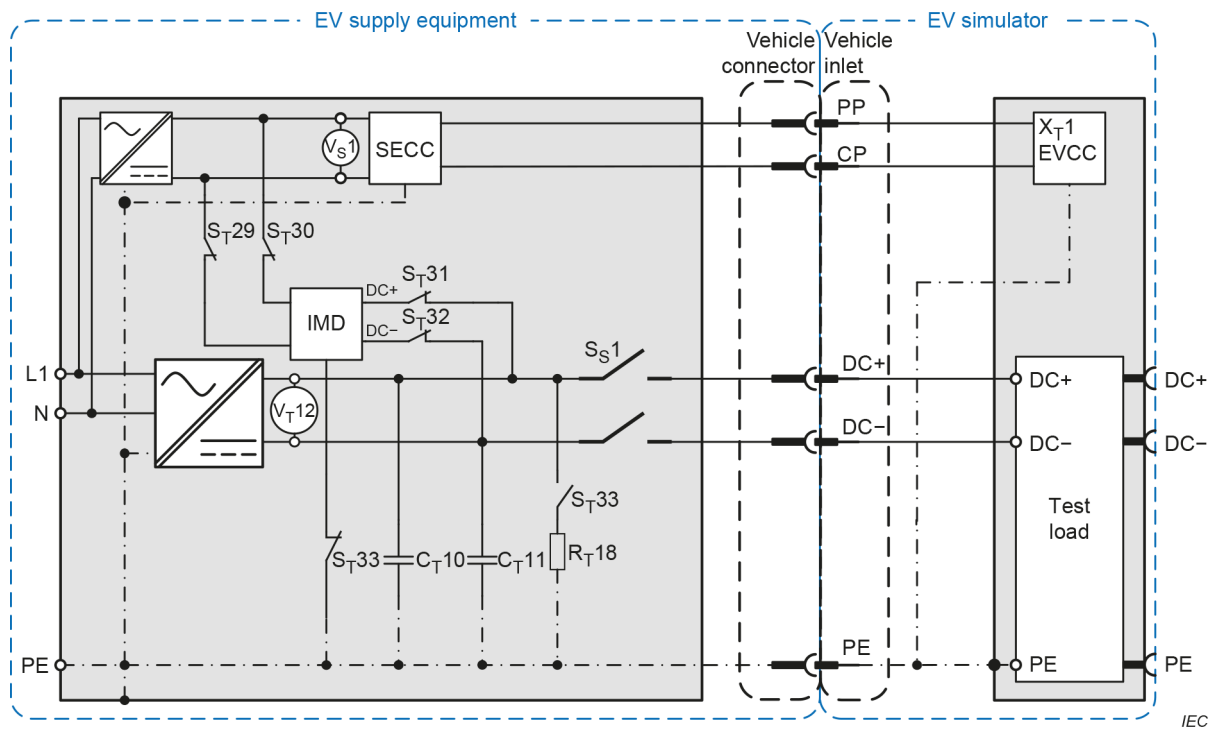
**Key**

L1, N	AC or DC supply network	$S_T$	switch or relay in the test setup
PE	protective conductor contact	$C_T$	capacitor in the test setup
PP	proximity pilot conductor contact	$V_T$	voltmeter in the test setup
CP	control pilot conductor contact of system C	$R_T$	resistor in the test setup
DC+	positive terminal of the side B	$V_S$	voltmeter in the EV supply equipment
DC-	negative terminal of the side B	$X_T$	voltage source for the proximity pilot circuit
SECC	supply equipment communication controller	EVCC	electric vehicle communication controller
test load	test load according to 102.2.4 unless otherwise specified (see Figure 132)		

**Figure CC.35 – Test setup for IMD measurement connections**

For the test, the following parameters shall apply.

- $C_{T10} = C_{T11}$  = capacitance installed in the EV supply equipment between DC+/DC- and the protective conductor.
- $R_{T18} = 90 \text{ k}\Omega$  = fault resistance between DC+ and the protective conductor.
- $V_{T12}$  = the lowest voltage that can be applied during cable-check at the following condition:

$$V_{EV\_max} = V_{EVSE\_min} + 100 \text{ V.}$$

The switches  $S_{T31}$ ,  $S_{T32}$ ,  $S_{T33}$  and  $S_{T34}$  are added for this test. Any redundant measurement connections shall be passed through the single switch associated with that measurement location according to Figure CC.35.

The EV supply equipment manufacturer should identify redundant measurement connections for this test.

Power supply for the IMD has switches  $S_{T29}$  and  $S_{T30}$  to simulate loss of supply to the IMD. Switch  $S_{T29}$  may be the same as  $S_{T33}$  in some designs.

All the combinations in Table CC.28 shall be tested as different test cases.

**Table CC.28 – Test cases for the functional check of the IMD**

Test	Test case	$S_{T34}$	$S_{T31}$	$S_{T32}$	$S_{T33}$	$S_{T30}$	$S_{T29}$
Normal operation	1	Open	Closed	Closed	Closed	Closed	Closed
IMD connection to the protective conductor	2a	Open	Closed	Closed	Open	Closed	Closed
	2b	Closed	Closed	Closed	Open	Closed	Closed
IMD measurement connections	3a	Open	Open	Closed	Closed	Closed	Closed
	3b	Closed	Open	Closed	Closed	Closed	Closed
	3c	Open	Closed	Open	Closed	Closed	Closed
	3d	Closed	Closed	Open	Closed	Closed	Closed
	3e	Open	Open	Open	Closed	Closed	Closed
	3f	Closed	Open	Open	Closed	Closed	Closed
IMD power supply connections	4a	Open	Closed	Closed	Closed	Open	Closed
	4b	Closed	Closed	Closed	Closed	Closed	Open
	4c	Open	Closed	Closed	Closed	Open	Open

NOTE The test with  $R_{T18}$  is necessary because the IMD still detects a mains voltage even if  $S_{T33}$  is open.

**CC.7.6.21.4 Preconditions**

This test is a "white box" test, where the EV supply equipment needs to be prepared according to the test setup.

**CC.7.6.21.5 Definitions and calculations**

None.

**CC.7.6.21.6 Actions**

Test all required test cases by repeating the following actions.

- 1) Prepare the test setup for normal operation.
- 2) The FPT sequence shall be successfully done until  $t = t3$ .
- 3) Execute one of the required test conditions (1 – 4c).
- 4) The FPT sequence shall be successfully done until  $t = t6$  after completing the cable-check according to Figure CC.5, including message "CableCheckReq <4a>" using  $V_{EV\_max} = V_{EVSE\_min} + 100 \text{ V}$ .
- 5) Log the response message of the EV supply equipment.

**CC.7.6.21.7 Expected results**

At least after completing the cable-check phase, the EV supply equipment shall send message CableCheckRes <4b> with parameters "EVSEIsolationStatus" according to CC.4.1.4, "EVSEProcessing" = 'Finished', and:

- "EVSEStatusCode" = 'Ready', if the insulation status is 'Valid' in normal operation (test case 1), or
- "ResponseCode" = 'FAILED', if the EV supply equipment detects an error in all fault test cases (test cases 2a to 4c).

## **Annex DD** (informative)

### **Bidirectional power transfer control**

#### **DD.1 General**

Annex DD provides basic information for bidirectional power transfer (BPT) between the BPT EV supply equipment and the EV.

An important aspect of the BPT is the ability of the BPT EV supply equipment to change the direction of energy transfer between FPT and RPT or to remain idle, that is, to pause energy transfer. This can be achieved by the methods described in Clause DD.2.

If the BPT EV supply equipment is designed to be connected and provide power to residential or commercial building(s) and/or the grid, then

- side A circuits should consider the requirements in IEC 62909-1, IEC 62909-2 and IEC 62909-3<sup>10</sup>, for example, power quality, load dump, voltage fluctuations,
- connection of the side A circuits to the supply network should consider the requirements in IEC 60364-5-55 and in the IEC 60364-8 series, and
- for upstream communication, for example, to home, the IEC 62439 series can be considered.

#### **DD.2 Forward power transfer (FPT) and reverse power transfer (RPT)**

In addition to all applicable requirements in this document, including the requirements in 6.3.1, which defines FPT, the following operation methods can be applied to the BPT EV supply equipment.

##### a) Dynamic BPT

Under this configuration, the EV and the BPT EV supply equipment will exchange information about voltage, current and/or power limits before and during the sequence through digital communication.

The BPT EV supply equipment will deliver energy to the EV or draw energy from the EV less than or equal to the communicated limits and inform the EV about the actual voltage and current during energy transfer.

The direction of the energy transfer can be changed seamlessly anytime, that is, between FPT and RPT without transferring to a shutdown (stage).

##### b) Switching between FPT and RPT

To switch between FPT and RPT, the BPT EV supply equipment should perform a normal shutdown and remain in pause.

The BPT EV supply equipment should reconfigure the PEC to change the direction of energy flow.

The BPT EV supply equipment should re-initiate by performing the necessary phases of the initialization stage and, if the initialisation stage is sufficiently completed, continue with transfer stage.

---

<sup>10</sup> Under preparation. Stage at the time of publication: IEC PRVC 62909-3:2023.

## Annex EE (normative)

### Test load impedance verification

#### EE.1 General

Annex EE specifies the procedure to verify the calibration of the test load used for tests as specified in this document.

#### EE.2 Response curve verification

From 1 Hz to 150 kHz, the magnitude of the impedance between DC+ and DC– of the test load shall be verified for

- system A and system B: using Formula (EE.1),
- system A for current ripple measurements: using Formula (EE.2),
- system C: using Formula (EE.2),

with the parameters in Table EE.1, based on a simplification of Figure 132.

$$|Z_{\text{load}}| = \left| \frac{1}{\frac{1}{R_{\text{Batt}}} + j\omega L} \right| \quad (\text{EE.1})$$

where

$Z_{\text{Load}}$  is the test load impedance, expressed in ohms;

$R_{\text{Batt}}$  is the test load resistance, expressed in ohms;

$L$  is the test load inductance, expressed in henrys;

$$|Z_{\text{load}}| = \left| \frac{1}{\frac{1}{R_{\text{Batt}}} + \frac{1}{R_{\text{Cx}} + \frac{1}{j\omega C_{\text{X}}}}} + j\omega L \right| \quad (\text{EE.2})$$

where

$Z_{\text{Load}}$  is the test load impedance, expressed in ohms;

$R_{\text{Batt}}$  is the test load resistance, expressed in ohms;

$C_{\text{X}}$  is the X capacitance, expressed in farads;

$R_{\text{Cx}}$  is the resistance of the  $C_{\text{X}}$  capacitor, expressed in ohms;

$L$  is the test load inductance, expressed in henrys.

**Table EE.1 – Test load parameters**

System	Parameter	Minimum value	Average value	Maximum value
A and B	$R_{\text{Test\_Load}}^{\text{a}}$	50 mΩ	75 mΩ	100 mΩ
	$L_{\text{T}} = L_{\text{T}3} + L_{\text{T}4}^{\text{d}}$	1 μH	2 μH	3 μH
A <sup>e</sup>	$R_{\text{Test\_Load}}^{\text{a}}$	1 Ω	3 Ω	5 Ω
	$C_{\text{T}6}^{\text{b}}$	3 300 μF	5 600 μF	8 200 μF
	$R_{\text{CT}6}^{\text{c}}$	10 mΩ	20 mΩ	30 mΩ
	$L_{\text{T}} = L_{\text{T}3} + L_{\text{T}4}^{\text{d}}$	1 μH	2 μH	3 μH
C	$R_{\text{Test\_Load}}^{\text{a}}$	50 mΩ	75 mΩ	100 mΩ
	$C_{\text{T}6}^{\text{b}}$	330 μF	470 μF	820 μF
	$R_{\text{CT}6}^{\text{c}}$	10 mΩ	20 mΩ	30 mΩ
	$L_{\text{T}} = L_{\text{T}3} + L_{\text{T}4}^{\text{d}}$	1 μH	2 μH	3 μH

<sup>a</sup> Low frequency battery system equivalent series resistance.  
<sup>b</sup> EV X-capacitors.  
<sup>c</sup> Equivalent series resistance of EV X-capacitors.  
<sup>d</sup> Inductance of vehicle power supply circuit (for example, cabling).  
<sup>e</sup> Load for current ripple measurements. The battery system resistance is the load resistance to reach a specific operating point.

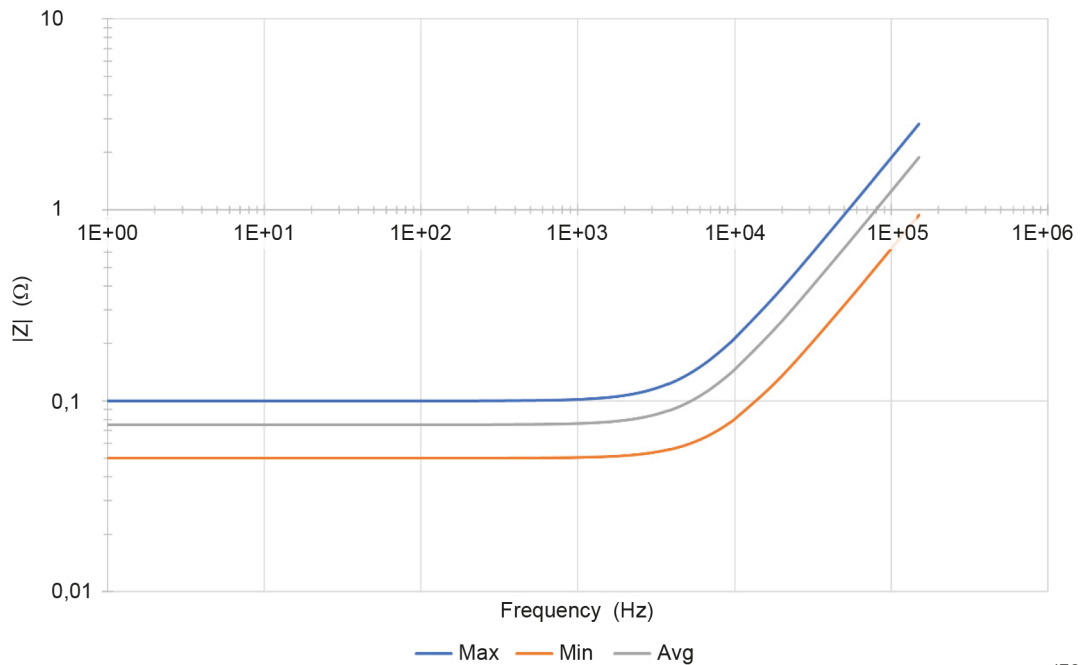

IEC

**Figure EE.1 – Magnitude of the impedance of the test load between DC+ and DC– for system A and system B**

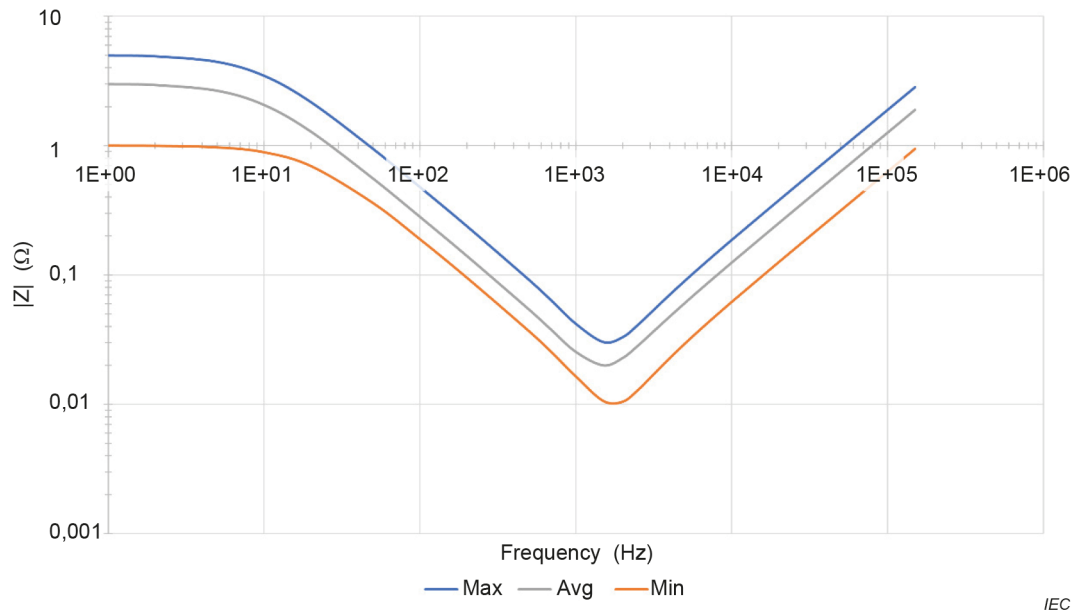

**Figure EE.2 – Magnitude of the impedance of the test load between DC+ and DC– for system A for current ripple measurements**

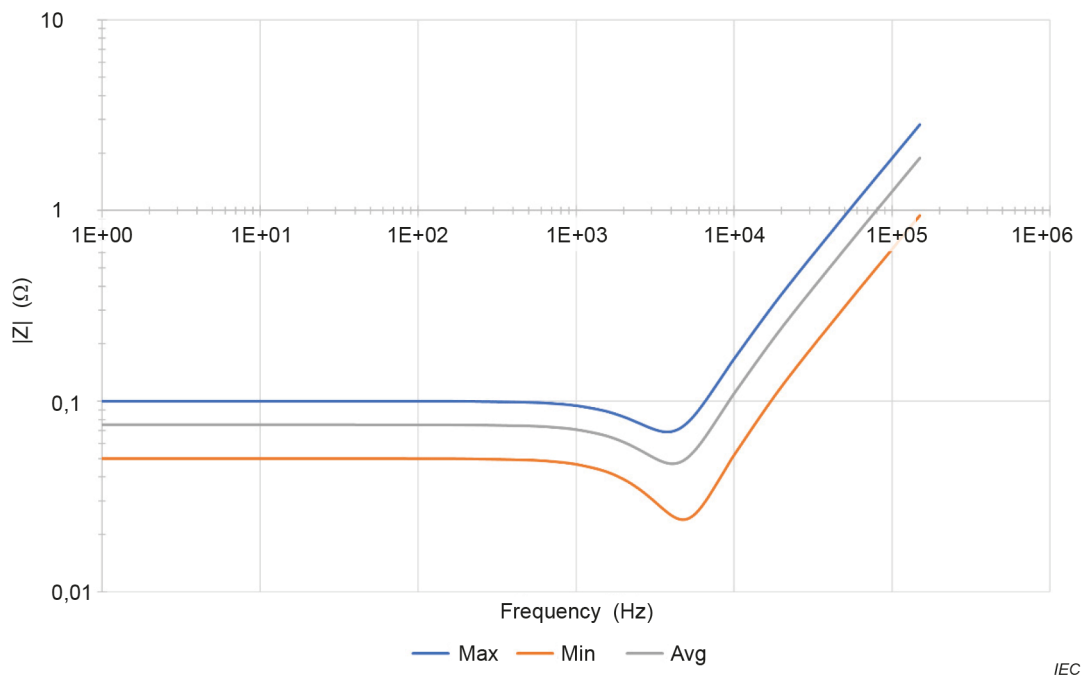

**Figure EE.3 – Magnitude of the impedance of the test load between DC+ and DC– for system C**

The measured magnitude of the impedance  $|Z|$  shall be plotted in a bode-plot. The magnitude shall remain between the minimum and maximum as specified in the respective figures. The phase shift  $\phi$  of the impedance does not need to be verified.

The impedance of the test load has influence on the performance characteristics and compatibility between the EV supply equipment and EV. If the EV impedance significantly deviates from the test load impedance, the compatibility and performance during energy transfer can be negatively affected, for example, due to unexpected resonant frequencies, high inductance, etc.

The test load manufacturer shall specify under what conditions the magnitude of the impedance shall be verified and the verification procedure, for example once per year, using the method described in Clause EE.3.

### EE.3 Test setup for test load verification (informative)

The impedance of the test load used in several tests needs to be verified. This test setup describes how to verify this. It assumes that the load impedance will be the same for all operating points specified in 102.2.5, therefore only verifies the impedance at low current and at a single voltage. If this assumption is incorrect, the test needs to be modified to cover the needed operating points specified in 102.2.5, or another method may be needed. An example of the test setup is shown in Figure EE.4.

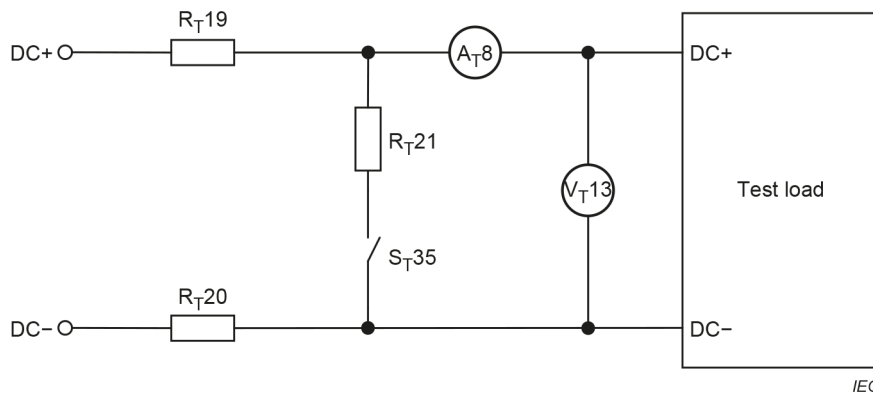

#### Key

DC+	positive terminal of the voltage source	S <sub>T</sub>	switch or relay in the test setup
DC-	negative terminal of the voltage source	V <sub>T</sub>	voltmeter in the test setup
Test load	test load according to 102.2.4 (see Figure 132)	A <sub>T</sub>	ammeter in the test setup
R <sub>T19</sub>	10 Ω resistor	R <sub>T20</sub>	10 Ω resistor
R <sub>T21</sub>	400 Ω resistor		

**Figure EE.4 – Test setup for test load verification**

A DC voltage source can be used to supply the test load with a constant DC voltage, for example 400 V DC. The voltage source has been decoupled with 2 × 10 Ω resistors (R<sub>T19</sub> and R<sub>T20</sub>). The test load can be configured to a constant voltage, with a current of 2 A, for example, 360 V.

Switch S<sub>T35</sub> will be opened and closed with a specific frequency. This frequency will be swept from 1 Hz to 150 kHz with 5 steps for each decade. More measurement points may be needed between 1 kHz and 10 kHz.

The measured current A<sub>T8</sub> and voltage V<sub>T13</sub> over the load will be filtered with a band-pass filter to only allow for the measurement frequency.

#### **EE.4 Result**

The measured magnitude of the impedance shall fall between the minimum and maximum limits as shown in

- Figure EE.1 for system A (excluding current ripple measurements),
- Figure EE.1 for system B,
- Figure EE.2 for system A for current ripple measurements, and
- Figure EE.3 for system C.

For example: the line representing the average (avg) falls between the minimum and maximum, and therefore passes the test.

## **Annex FF** (normative)

### **Multi-side B separated EV supply equipment**

#### **FF.1 General**

Annex FF provides specific requirements for FPT by using a multi-side B EV supply equipment. A multi-side B EV supply equipment is an EV supply equipment with two or more vehicle connectors. As a part of the EV supply equipment, all general requirements for EV supply equipment in the body text of this document also apply to the multi-side B EV supply equipment unless otherwise specified in Annex FF.

#### **FF.2 Classification and use case of multi-side B EV supply equipment**

##### **FF.2.1 System operation**

- Multi-side B EV supply equipment with non-simultaneous operation.
- Multi-side B EV supply equipment with simultaneous operation.

##### **FF.2.2 Side B system**

- Multi-system A.
- Multi-system B.
- Multi-system C.
- System A and system B.
- System A and system C.
- System B and system C (under consideration).
- System A, system B and system C (under consideration).

##### **FF.2.3 Configuration**

- a) Multi-side B EV supply equipment with a single PEC.
- b) Multi-side B EV supply equipment with multiple (two or more) PECs.

The possible combinations for multi-side B EV supply equipment with respect to the classification are shown in Table FF.1.

**Table FF.1 – Possible combinations for multi-side B EV supply equipment**

Use case						Configuration		
Operation		Side B system					PEC	
Non-Simultaneous	Simultaneous	A	B	C	A and B	A and C	Single	Multiple
X		X					X	
X			X				X	
X				X			X	
X					X		X	
X						X	X	
X	X	X						X
X	X		X					X
X	X			X				X
X	X				X			X
X	X					X		X

Examples of system schematics for the use cases derived from Table FF.1 are shown in Figure FF.1 and Figure FF.2.

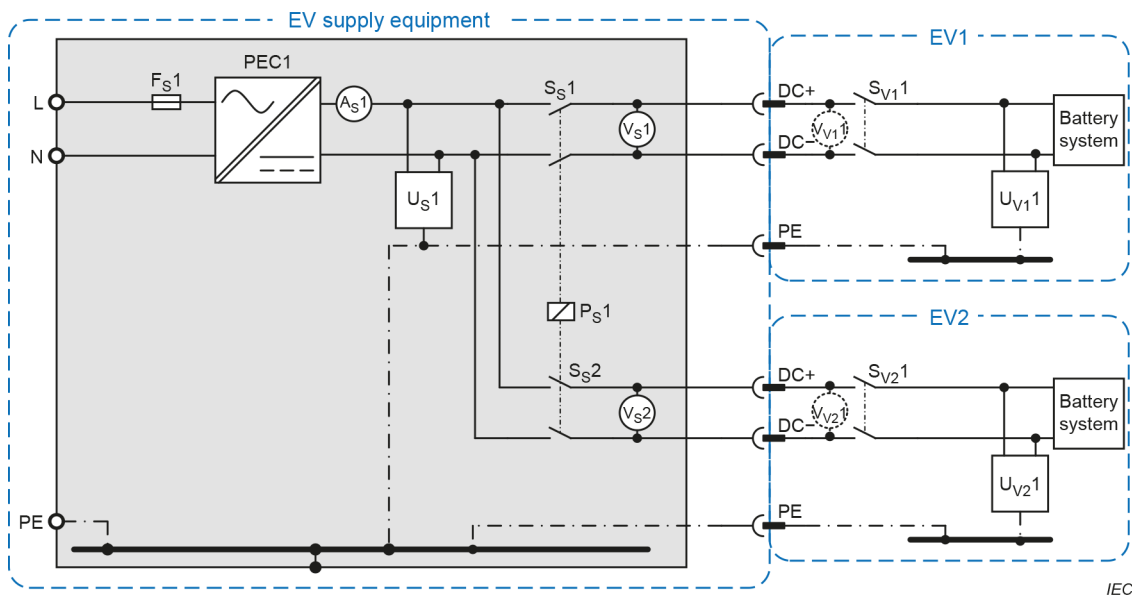

IEC

**Key**

L1, N	AC or DC supply network	$S_S$	switch or relay in the EV supply equipment
PE	protective conductor contact	$S_V$	switch or relay in the EV
DC+	positive terminal of side B	$A_S$	ammeter in the EV supply equipment
DC-	negative terminal of side B	$V_S$	voltmeter in the EV supply equipment
PEC	power electronic converter	$V_V$	voltmeter in the EV
$U_S$	IMD of the EV supply equipment	$F_S$	over-current protection device in the EV supply equipment
$U_V$	IMD of the EV	$P_S$	electrical and/or mechanical interlock

**Figure FF.1 – Example of a multi-side B EV supply equipment with a single PEC**

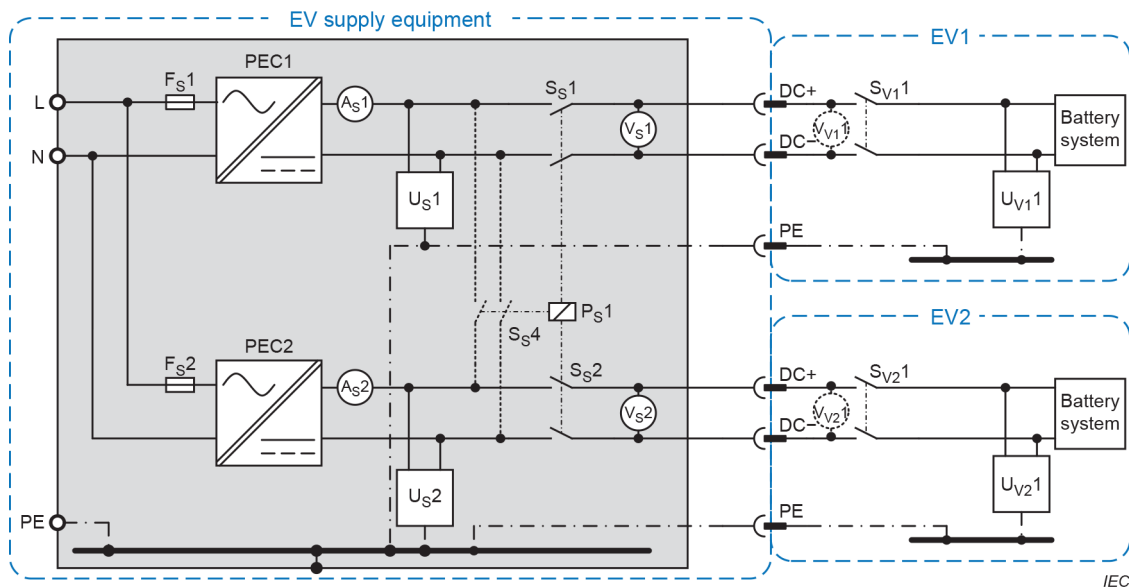

### Key

L1, N	AC or DC supply network	$S_S$	switch or relay in the EV supply equipment
PE	protective conductor contact	$S_V$	switch or relay in the EV
DC+	positive terminal of side B	$A_S$	ammeter in the EV supply equipment
DC-	negative terminal of side B	$V_S$	voltmeter in the EV supply equipment
PEC	power electronic converter	$V_V$	voltmeter in the EV
$U_S$	IMD of the EV supply equipment	$F_S$	over-current protection device in the EV supply equipment
$U_V$	IMD of the EV	$P_S$	electrical and/or mechanical interlock

**Figure FF.2 – Example of a multi-side B EV supply equipment with multiple PECs**

## FF.3 Constructional requirements of a side B system

A storage means according to IEC 61851-1:2017, 11.7, shall be provided for each vehicle connector when not in use. National codes can apply regarding the maximum cable length. Clearance and creepage distance of contactors in open state shall be in accordance with 12.3 for at least basic insulation.

The side B system shall also be equipped with a mechanical disconnection device such as a relay/contactor. This mechanical disconnection device shall be installed in each of the side B circuit (DC+ and DC–), and shall be capable of disconnecting the side B live parts (DC+ and DC–) of the EV supply equipment from the EV when the present current at side B is equal to the rated boost current of the EV supply equipment at side B.

*Compliance is checked by design review.*

### FF.3.1 Constructional requirements of a side B system according to Annex AA

The side B system shall be equipped with a vehicle connector according to IEC 62196-3 or IEC TS 62196-3-1, configuration AA. To ensure proper functionality, the side B system shall be equipped with the necessary hardware for digital communication and energy transfer (for example, CAN transceiver, resistors, switches, contactors), according to Figure AA.1. System A side B circuits shall be equipped with contactors on DC+ and DC–.

*Compliance is checked by design review.*

### **FF.3.2 Constructional requirements of a side B system according to Annex BB**

The side B system shall be equipped with a vehicle connector according to IEC 62196-3 or IEC TS 62196-3-1, configuration BB. To ensure proper functionality, the side B system shall be equipped with the necessary hardware for digital communication and energy transfer (for example, CAN transceiver, auxiliary power device, switches, contactors), according to Figure BB.1. Vehicle connectors of system B shall be equipped with a means to ensure protection against access to hazardous parts with a standard test finger (IPXXB).

*Compliance is checked by design review.*

### **FF.3.3 Constructional requirements of a side B system according to Annex CC**

The side B system shall be equipped with a vehicle connector according to IEC 62196-3 or IEC TS 62196-3-1, configuration EE or configuration FF. To ensure proper functionality, the side B system shall be equipped with the necessary hardware for digital communication and energy transfer (for example, PWM oscillator, PLC chip, contactors), according to Figure CC.1 or Figure CC.2.

*Compliance is checked by design review.*

## **FF.4 Side B system performance**

### **FF.4.1 General performance requirements**

The side B systems shall be system A, system B, system C, both system A and system B or both system A and system C. The side B performance shall comply with the requirements in the body text of this document and with the requirements in the applicable annexes. If two or more side B systems can be used simultaneously, no individual or combination of side B systems shall cause interference with any other side B system.

*Compliance is checked by design review.*

### **FF.4.2 Performance of multi-side B EV supply equipment providing simultaneous operation**

If the sum of the rated boost power of the multi-side B EV supply equipment at each side B is more than the rated maximum power of the multi-side B EV supply equipment at side B, the multi-side B EV supply equipment manufacturer shall specify the possibilities of power distribution in the user manual (for example, priority energy transfer or evenly distributed present power on each side B).

*Compliance is checked by design review.*

## **FF.5 Safety requirements**

### **FF.5.1 General safety requirements**

The protective conductor in each side B cable assembly of the multi-side B EV supply equipment shall be connected to a common protective earthing conductor.

All side B circuits shall be individually equipped with a means of insulation monitoring or earth leakage current monitoring, between side B live parts (DC+ and DC–) and the protective conductor of EV supply equipment, as specified in Annex AA, Annex BB or Annex CC. Y-capacitance at each side B circuit shall comply with the requirement in 8.105.3.

The reaction time of an IMD shall not be influenced during simultaneous operation by an earth leakage current monitoring device or other IMD of another side B system.

Circuit components, including devices used for separation, shall be rated for the rated maximum voltage of the multi-side B EV supply equipment at side B, including all specified tolerances of the side B circuits considering both normal and single insulation fault.

A single fault in a multi-side B EV supply equipment supporting more than one system (A, B and C) shall not cause a present voltage at the vehicle connector of a different system.

*Compliance is checked by design review.*

#### **FF.5.2 Short-circuit protection**

Each vehicle connector of a multi-side B EV supply equipment shall have individual short-circuit protection means. Such means shall comply with the requirements of the respective side B system given in 13.101.

*Compliance is checked by design review.*

#### **FF.5.3 Overload protection**

Each vehicle connector of a multi-side B EV supply equipment shall individually provide overload protection according to Clause 13.

*Compliance is checked by design review.*

#### **FF.5.4 Access to live parts through an unmated vehicle connector during energy transfer**

During energy transfer, a conductor connected to the accessible unmated vehicle connector shall be separated by basic or reinforced insulation from the live side B.

If separation is achieved by basic insulation, the voltage between a contact of an unmated vehicle connector and the protective conductor shall be  $\leq 60$  V DC continuously in normal operation and after 1 s under a first fault.

Requirements for the insulation barrier specified in 8.105.5 shall be applied to each side B circuit.

*Compliance is checked by the following test for normal operation and by design review for first fault.*

- 1) *One vehicle connector of the multi-side B EV supply equipment is mated to an EV simulator as defined in 102.2.3.*
- 2) *Start a communication session operating at OP3 on that vehicle connector of the multi-outlet EV supply equipment. See 102.2.5.*
- 3) *Start the measurement of voltage between each contact (DC+/DC–, DC+/PE and DC–/PE) for all remaining vehicle connectors of the multi-outlet EV supply equipment.*
- 4) *Stop FPT based on the stop sequence defined for the system associated with the mated vehicle connector.*
- 5) *The test is passed if the voltage values between all contacts are  $< 60$  V DC.*
- 6) *The test is repeated for every vehicle connector of the multi-side B EV supply equipment, one at a time.*

#### **FF.5.5 Additional safety requirements for multi-side B EV supply equipment providing simultaneous operation**

If the side B systems are equipped with switching devices, such as contactors, measures shall be taken to prevent unintended electrical connection of EVs caused by the failure of the switching device. These measures shall prevent a parallel connection between battery systems of different EVs. The protection can be achieved by one or combination of the following measures:

- allocation of diode to each side B circuit; the diode shall be installed in each side B circuit between the switching device and the vehicle connector;
- allocation of a fuse in each side B circuit equipped with a switching device;
- electrical or mechanical interlock of switching devices.

If a fault is detected in one or more side B circuits, the multi-side B EV supply equipment shall perform a shutdown in all the involved side B circuits.

*Compliance is checked by design review.*

#### **FF.5.6 Diagnostic check of mechanical disconnection device in the side B system**

The multi-side B EV supply equipment shall perform the diagnostic check of the mechanical disconnection device installed in the side B system to prevent unexpected energy transfer from an EV to the multi-side B EV supply equipment, or between the two or more EVs simultaneously connected to the multi-side B EV supply equipment in case the mechanical disconnection device is welded (ON stuck), and to prevent hazardous voltage at the unmated vehicle connector.

As the minimum requirement, the diagnostic shall check the welding (ON stuck) of the mechanical disconnection device. Diagnostic checks of other failures such as OFF stuck and erratic actuation are not mandatory but still recommended.

If the diagnostic check is performed before the start of the energy transfer stage and the ON stuck failure is detected, the multi-side B EV supply equipment shall perform an error shutdown in all the side B circuits connected to the welded mechanical disconnection device.

If the diagnostic check is performed after the completion of a single energy transfer stage and the ON stuck failure is detected, the multi-side B EV supply equipment shall prohibit further communication sessions for all the side B systems connected to the welded mechanical disconnection device, until the mechanical disconnection device is properly replaced or repaired.

*Compliance is checked by design review.*

#### **FF.5.7 Interconnected side B live parts (DC+/DC–) in multi-side B EV supply equipment**

The multi-side B EV supply equipment shall not connect side B live parts (DC+/DC–) between multiple side B circuits.

## **Annex GG** (informative)

### **Communication and energy transfer process between the EV supply equipment and the EV**

#### **GG.1 General**

Annex GG provides the general information on the communication and energy transfer process between EV supply equipment and EV.

The requirements of digital communication during the coupling session between EV supply equipment and EV are defined in IEC 61851-24.

EVs are equipped with battery systems with different technologies and voltage. Accordingly, the energy transfer process is managed by the EV in order to ensure energy transfer to different types of battery systems.

EVs are equipped with an EVCC for communication session management. The EV supply equipment has means allowing the EVs to control the energy transfer parameters of the EV supply equipment.

#### **GG.2 System configuration**

The communication between the EV supply equipment and the EV can be established via basic communication and digital communication.

Key steps in the energy transfer control process, such as start of a communication session and normal/emergency shutdown, is managed through the basic communication with signal exchange via the control pilot lines in the EV supply equipment.

In addition to the basic communication, the EV supply equipment is equipped with digital communication means in order to exchange the control parameters for energy transfer between the EV supply equipment and the EV. The following digital communication means are used by the systems defined in Annex AA, Annex BB and Annex CC:

- a) control area network (CAN) over dedicated circuits for digital communication according to ISO 11898-1; or
- b) power line communication (PLC) over control pilot circuit.

#### **GG.3 Energy transfer control process and state**

##### **GG.3.1 General**

The energy transfer control process of the EV supply equipment consists of the following three stages:

- process before the start of energy transfer (initialization stage): initialization includes pre-charge phase if required; pre-charge is the final phase of the initialization stage;
- process during energy transfer (energy transfer stage);
- process of shutdown (shutdown stage).

The EV supply equipment and the EV synchronize control process with each other. The following signals and information are used for the synchronization:

- signals through the pilot wire circuit;
- parameters through the circuits for digital communication;
- measurement values such as present current and voltage at side B, through the circuits for digital communication.

The EV supply equipment and the EV preserve specified time constraints and control timings for ensuring smooth energy transfer control and operation.

FPT sequence diagrams are system specific and described in Annex AA, Annex BB, and Annex CC. Digital communication parameters, formats, and other digital communication requirements are specified in IEC 61851-24.

### **GG.3.2 Description of the initialization stage**

In this stage, the EV and the EV supply equipment exchange their operational limitations and relevant parameters for energy transfer control. Messages, such as rated maximum voltages, rated maximum currents, etc. are also transferred to each other. The present voltage at side B is measured for checking whether the battery system and the EV supply equipment are connected before the start of the energy transfer stage and whether the battery system and the EV supply equipment are disconnected after the end of the energy transfer stage. The EV supply equipment shall not proceed with the next stage of the communication session unless it verifies the compatibility with the EV. After the compatibility check, the EV supply equipment conducts the cable-check phase. The vehicle connector is latched before the cable-check phase.

### **GG.3.3 Description of the energy transfer stage**

In this stage, the EV continues to send a target current or target voltage values to the EV supply equipment throughout the energy transfer stage. Either of the following two algorithms is taken.

#### **a) CCM**

- The battery system can be charged using CCM with the EV as master and the EV supply equipment as slave.
- The EV supply equipment receives the target current of the EV, throughout the energy transfer stage.
- The EV supply equipment considers the target current of the EV to set the target current of the EV supply equipment, and control the present current at side B.
- The target current of the EV is communicated to the EV supply equipment at regular intervals according to the system requirements.
- The EV supply equipment controls the present current at side B, responding to the target current of the EV.

#### **b) CVM**

- The battery system can be charged using CVM with the EV as master and the EV supply equipment as slave.
- The EV supply equipment receives the target voltage of the EV, throughout the energy transfer stage.
- The EV supply equipment considers the target voltage of the EV to set the target voltage of the EV supply equipment, and control the present voltage at side B.
- The target voltage the EV is communicated to the EV supply equipment at regular intervals according to the system requirements.
- The EV supply equipment controls the present voltage at side B, responding to the target voltage of the EV.

**GG.3.4 Description of the shutdown stage**

After completion of the energy transfer stage, the shutdown stage allows the EV supply equipment to return to the conditions prior to the communication session. When the EV or EV supply equipment indicate the end of the energy transfer stage, the EV supply equipment reduces the present current at side B to 0 A DC. The EV disconnection device open at near zero present current at side B. The EV supply equipment or the EV unlatches the vehicle connector only if the present voltage at side B between DC+ and DC– is  $\leq 60$  V DC (see 6.3.1.107).

## Annex HH (informative)

### Touch current and touch impulse current

#### HH.1 General

Annex HH provides information about the influence of Y-capacitances on the EV and the EV supply equipment to tests as specified in this document.

Compliance to the Y-capacitance limit of the EV supply equipment is covered by 8.105.1.

Compliance to the limitation of steady state touch current and touch impulse current is covered by 8.101.4.

Guidance on the measurement of the mandatory total Y-capacitance limit in the EV is specified in ISO 17409:2020, Annex A.

Figure HH.1 shows an ideal/equivalent circuit of an EV and an EV supply equipment connected to each other for the purpose of energy transfer. The PEC is assumed to be an ideal voltage source. The equivalent circuit in Figure HH.1 represents the PEC in the EV supply equipment, the EV/RESS and the cabling for this analysis, because they influence each other.

Table HH.1 shows key(s) and exemplary values for design verification. The rated maximum voltage at side B of the EV supply equipment is specified by  $V_{DC}$  in Table HH.1.

Figure HH.1 and Table HH.1 allow for an evaluation of these trade-offs and can be used for design verification of the EV supply equipment. A simplification of the equivalent circuit is shown in Figure HH.2. In Figure HH.4, the results of the derivation have been plotted for steady-state touch current  $I_H$  (top dot), and touch impulse current  $I_{RMS}, T_{3RC}$  (impulse current dot) as indicated by Table HH.1.

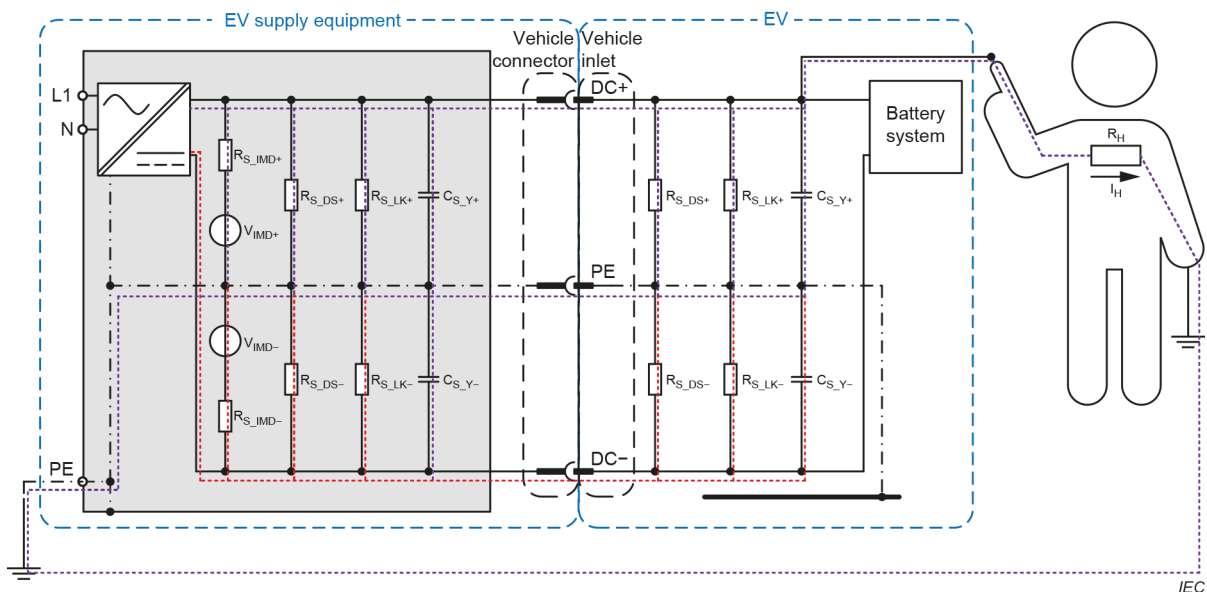

**Figure HH.1 – EV and EV supply equipment equivalent circuit**

$R_{DS+\_EVSE}/R_{DS-\_EVSE}$  represent the resistances in the EV supply equipment that are part of the design, for example: voltage measurements, discharge resistors, components with a known leakage, etc. Equally for the EV,  $R_{DS+\_EV}/R_{DS-\_EV}$  have a similar function. The IMD used in this example has an internal measurement circuit represented by  $R_{IMD+}/R_{IMD-}$  and a voltage source connected to the protective conductor, with a maximum voltage of 50 V DC, represented by  $V_{IMD}$ . Other IMD implementations may be considered.

The Y-capacitances  $C_{Y+\_EVSE}/C_{Y-\_EVSE}$  in the EV supply equipment that bridge from DC+/DC– to the protective conductor or any other circuit are specified according to 8.105.1 by a maximum limit of 500 nF for  $C_{Y+\_EVSE}/C_{Y-\_EVSE}$ .

For the EV, the limits for Y-capacitances (indicated by  $C_{Y+\_EV}/C_{Y-\_EV}$ ), are specified in ISO 17409:2020, 9.9.

Due to aging of various components, additional leakage current between DC+ and DC– and the protective conductor may be modelled by  $R_{LK+\_EVSE}/R_{LK-\_EVSE}$  for the EV supply equipment, and by  $R_{LK+\_EV}/R_{LK-\_EV}$  for the EV.

If this leakage is mainly asymmetrical, this is the worst case for the impulse current and the steady state touch current. For example, by having a high value of resistance for  $R_{LK+\_EV}$  and a low value for  $R_{LK-\_EV}$ , as shown in Table HH.1. It is assumed that, as a consequence of two independent faults, a person/human body may touch because it is assumed that the ordinary person may touch DC+ and the protective conductor.

The human body is represented as a resistor  $R_H$ , with a value according to the lowest hand-to-hand resistance, as specified in IEC 60479-1:2018, Table 10. This pathway is consistent with touching a live part that has become accessible due to a failure of the side B cable assembly with one hand, and an exposed conductive parts of the vehicle connector, EV or EV supply equipment with the other hand of the human body.

**Table HH.1 – Key(s) and exemplary values for design verification**

Quantity symbol	Quantity name	Calculation formula	Value	Unit
$V_{DC}$	Maximum voltage at side B		920	V
$V_{IMD+}$	IMD measurement voltage +		50	V
$V_{IMD-}$	IMD measurement voltage –	$= -V_{IMD+}$	-50	V
$R_{IMD+}$	IMD measurement resistance +		120,000E+03	$\Omega$
$R_{IMD-}$	IMD measurement –		120,000E+03	$\Omega$
$R_{DS+\_EVSE}$	Designed resistance EVSE +		2,000E+06	$\Omega$
$R_{DS-\_EVSE}$	Designed resistance EVSE -		2,000E+06	$\Omega$
$R_{LK+\_EVSE}$	Leakage resistance EVSE +		100,000E+06	$\Omega$
$R_{LK-\_EVSE}$	Leakage resistance EVSE –		100,000E+06	$\Omega$
$R_{DS+\_EV}$	Designed resistance EV +		100,000E+06	$\Omega$
$R_{DS-\_EV}$	Designed resistance EV –		100,000E+06	$\Omega$

Quantity symbol	Quantity name	Calculation formula	Value	Unit
$R_{LK+_EV}$	Leakage resistance EV +		100,000E+06	$\Omega$
$R_{LK-_EV}$	Leakage resistance EV -		112,000E+03	$\Omega$
$R_H$	Human body representation		575	$\Omega$
$C_{Y+EV}$	Y capacitance EV +		869,57E-09	F
$C_{Y-EV}$	Y capacitance EV -		869,57E-09	F
$C_{Y+EVSE}$	Y capacitance EVSE +		500,00E-09	F
$C_{Y-EVSE}$	Y capacitance EVSE -		500,00E-09	F
$C_{TOT}$	Total Y capacitance system	$= C_{Y+EV} + C_{Y-EV} + C_{Y+EVSE} + C_{Y-EVSE}$	2,74E-06	F
$R_{SYS+}$	System resistance +	$= 1 / (1 / R_{DS+_EVSE} + (1 / R_{LK+_EVSE}) + (1 / R_{DS+_EV}) + (1 / R_{LK+_EV}) + (1 / R_H))$	575	$\Omega$
$R_{SYS-}$	System resistance -	$= 1 / (1 / R_{DS-_EVSE} + (1 / R_{LK-_EVSE}) + (1 / R_{DS-_EV}) + (1 / R_{LK-_EV}))$	105,836E+03	$\Omega$
$R_{SYS+NH}$	$R_{SYS+}$ without human	$= 1 / (1 / R_{DS+_EVSE} + (1 / R_{LK+_EVSE}) + (1 / R_{DS+_EV}) + (1 / R_{LK+_EV}))$	1,887E+06	$\Omega$
$R_{SYS}$	Total system resistance	$= 1 / ((1 / R_{SYS+}) + (1 / R_{SYS-}))$	572	$\Omega$
$R_{IMD}$	Total IMD resistance	$= 1 / ((1 / R_{IMD+}) + (1 / R_{IMD-}))$	60,000E+03	$\Omega$
$R_{SYS\_NH}$	$R_{sys}$ without human	$= 1 / ((1 / R_{SYS+_NH}) + (1 / R_{SYS-}))$	100,215	$\Omega$
$R_{SYS\_NH+IMD}$	$R_{sys}$ including IMD resistance	$= 1 / ((1 / R_{SYS\_NH}) + (1 / R_{IMD+}) + (1 / R_{IMD-}))$	37,530	$\Omega$
$V_1$	Thevenin equiv. $V_1$	$= V_{DC} \times (R_{SYS-} / (R_{SYS+} + R_{SYS-}))$	915	V
$V_2$	Thevenin equiv. $V_2$	$= V_{IMD-} + (V_{DC} - V_{IMD+} - V_{IMD-}) \times (R_{IMD-} / (R_{IMD+} + R_{IMD-}))$	410	V
$V_{1\_NH}$	$V_1$ without human	$= V_{DC} \times (R_{SYS-} / (R_{SYS+NH} + R_{SYS-}))$	48,86	V
$V_{PE}$	$V_{PE}$ vs $V_{DC-}$	$= V_2 + (V_1 - V_2) \times (R_{IMD} / (R_{SYS} + R_{IMD}))$	910,26	V
$V_{PE\_NH}$	$V_{PE}$ without human	$= V_2 + (V_{1\_NH} - V_2) \times (R_{IMD} / (R_{SYS\_NH} + R_{IMD}))$	274,76	V
$I_H$	Steady state body current	$= (V_{DC} - V_{PE}) / R_H$	16,933E-03	A
$I_{PK}$	Peak body current	$= (V_{DC} - V_{PE\_NH}) / R_H$	1,122E+00	A
$I_{PK\_RMS}$	RMS body current	$= I_{PK} / \sqrt{6}$	0,458	A
$T_{3RC}$	Duration of impulse	$= 3 \times (1 / ((1 / R_{SYS}) + (1 / R_{IMD}))) \times C_{TOT}$	4,65E-03	s
E	Energy through body	$= ((V_{DC} - V_{PE\_NH})^2 - (V_{DC} - V_{PE})^2) \times 0,5 \times C_{TOT}$	570,08E-03	J
$T_{IMD}$	Minimum IMD reaction time	$= 15 \times R_{IMD} \times C_{TOT}$	2,465	s

The capacitances  $C_{Y+_EVSE}$ ,  $C_{Y-_EVSE}$ ,  $C_{Y+_EV}$ ,  $C_{Y-_EV}$ , are paralleled to form  $C_{TOT}$ .

The resistances to DC+ and DC– can be put in parallel to form  $R_{SYS+}$ , and  $R_{SYS-}$ , except for the IMD.  $R_{SYS+}$  without the human body representation is defined by  $R_{SYS+NH}$ . The total resistance of the system to the protective conductor, without the measurement resistance of the IMD, is represented by  $R_{SYS}$ . The total resistance of the IMD measurement circuit is represented by  $R_{IMD}$ .

The IMD only measures the total resistance of the system, excluding its own resistance to the protective conductor. This value is represented by  $R_{SYS\_NH}$ , without the human body representation from DC+ to the protective conductor. This measurement represents when the IMD will trigger an error shutdown, set to a fixed level, for example, 100 k $\Omega$ .

The total resistance from DC+ and DC– combined to the protective conductor, including the measurement resistance of the IMD, is represented by  $R_{SYS\_NH+IMD}$ .

Using these calculated values, we can determine the voltages before and after the human body representation is added to the system. This allows for the calculation of the impulse current and the steady-state leakage touch current that the human body representation is exposed to.

Figure HH.2 shows a simplified circuit of Figure HH.1. Figure HH.3 shows the Thevenin equivalent circuit of the circuit shown in Figure HH.1.

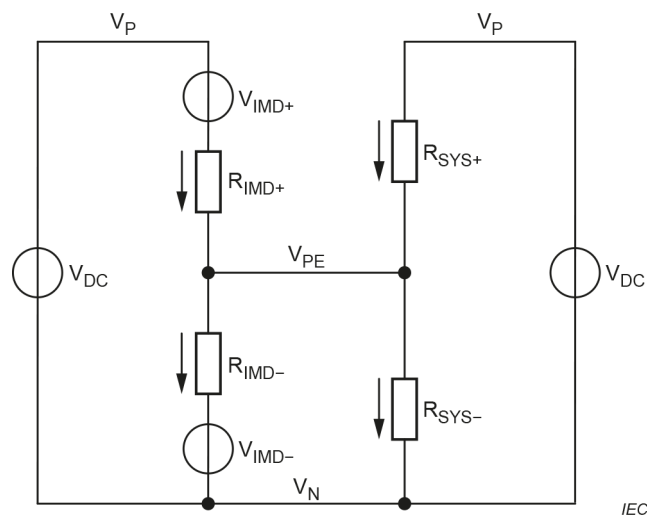

**Figure HH.2 – Circuit diagram simplification of the circuit in Figure HH.1**

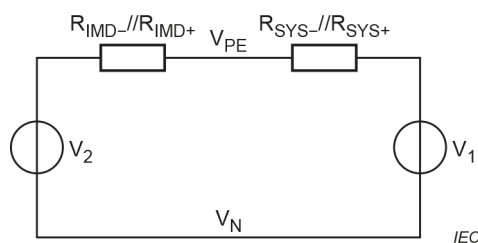

**Figure HH.3 –Thevenin equivalent circuit diagram of the circuit in Figure HH.1**

By calculating the intermediate voltage  $V_2$  for the IMD and  $V_1$  for the rest of the system, the voltage between the protective conductor and DC– can be determined. When the human body representation is not added to the system,  $V_{1\_NH}$  can be used.

When the voltage between DC+ and  $V_{PE}$  is known, the steady state leakage current  $I_H$  can be derived. This value can be represented by the leakage current dot (top dot) in Figure HH.4.

The peak current  $I_{PK}$  that will flow on when the human body representation is initially added to the system can be calculated using the voltage between DC+ and  $V_{PE\_NH}$  when the human body representation is not added to the system ( $V_{1\_NH}$ ), because this is what Y-capacitances  $C_{TOT}$  have been charged up to.

When determining the impulse current according to IEC 60479-2:2017, Clause 11, the RMS current and duration need to be calculated. The  $I_{RMS}$  current is determined by dividing  $I_{PK}$  by  $\sqrt{6}$  as described by IEC 60479-2:2017, 11.2.2.

The duration of the impulse,  $T_{3RC}$ , as a consequence of the discharge current through the human body representation, is calculated using the resistance of the whole system ( $R_{SYS}$ ), including the measurement resistance of the IMD ( $R_{IMD}$ ) in combination with the total capacitance of the system ( $C_{TOT}$ ).

The combination of  $I_{RMS}$  and  $T_{3RC}$  can be plotted as the impulse current dot (bottom dot) in Figure HH.4.

As additional information the energy  $E$  that has flown can be calculated based on the voltage before and after adding the human body representation and using the total capacitance of the system  $C_{TOT}$ . Also, the minimum IMD reaction time can be calculated based on the IMD measurement circuit resistance  $R_{IMD}$  and the total capacitance of the system  $C_{TOT}$ . This only represents a measurement under perfect conditions. Voltage fluctuations, interference and other factors would require the IMD to take more than 3 measurements, therefore, extending the time needed to determine the resistance of the system to the protective conductor.

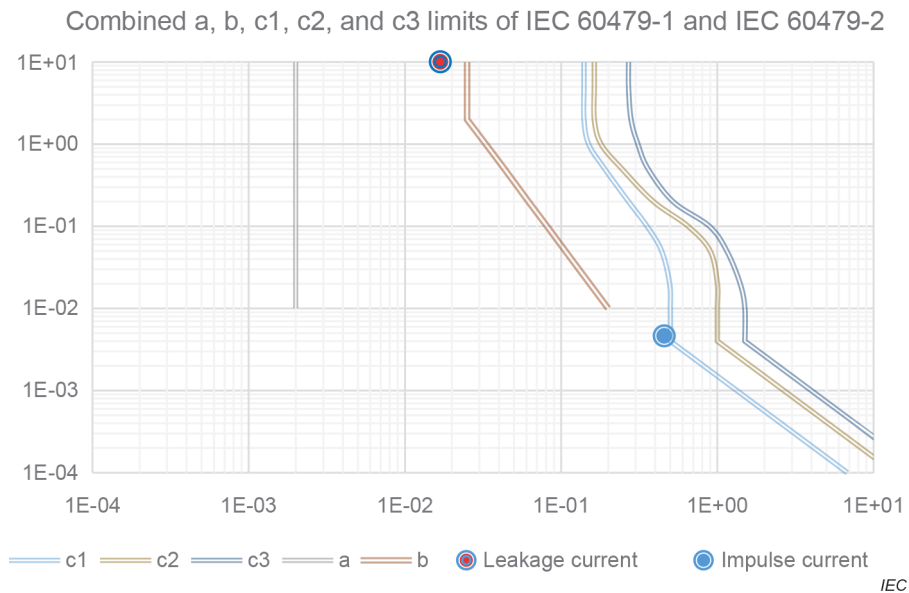
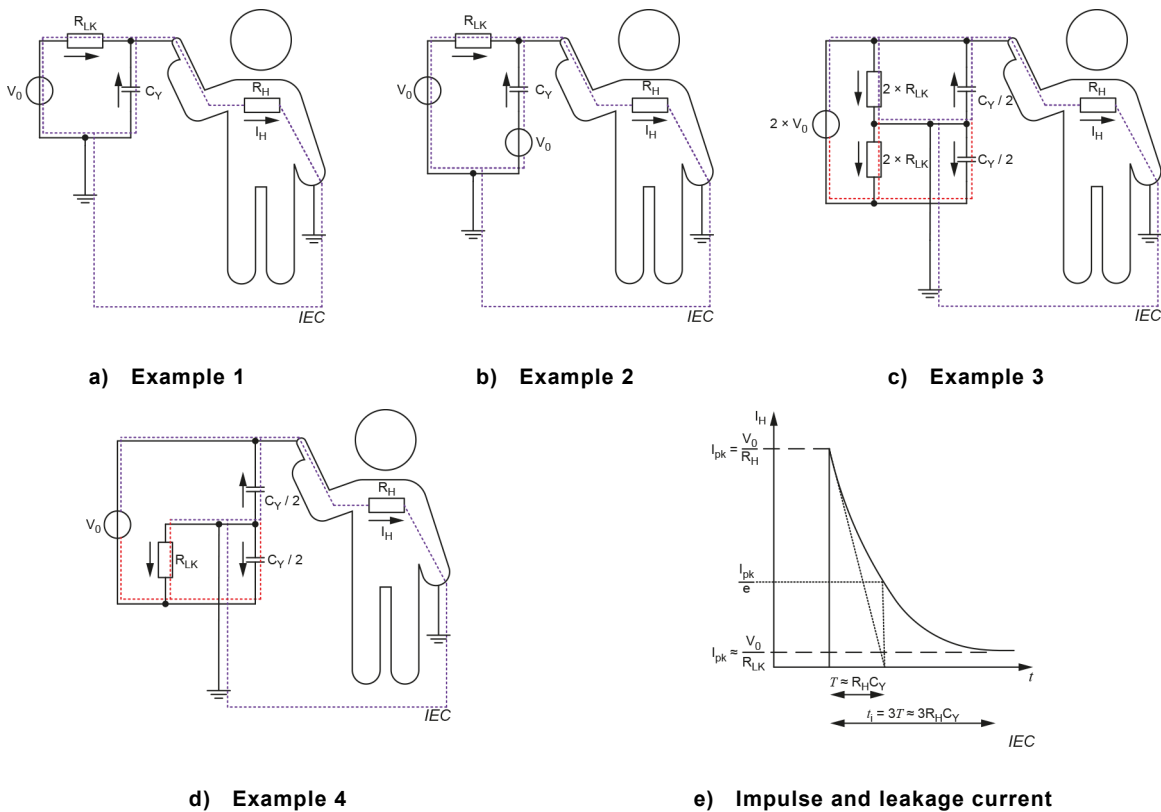

**Figure HH.4 – Leakage current and impulse current in relation to limits in IEC 60479 series**

### HH.2 Current through the human body

In case of a simultaneous failure of basic protection and fault protection, one of the side B live parts can become accessible, a person/human body can be exposed to a hazardous electric shock when touching the live part and other exposed conductive parts of the EV and EV supply equipment, including the protective conductor. The hazards associated with this scenario are formed by the impulse current due to the Y-capacitors and leakage currents due to resistances in the EV and EV supply equipment. These elements are bridging the insulation between the side B live parts (DC+/DC-) and the protective conductor.

The touch impulse current is determined by the manner that the stored energy in the Y-capacitors is released: through (a representation of) the human body, not the actual energy stored in the various elements of the system. Assuming  $R_{LK} \gg R_H$ , all the circuits depicted in Figure HH.5 have the same effects on the representation of the human body, because the current flow over time is identical. However, the actual energy stored in the capacitors is not identical.



**Figure HH.5 – Examples of circuits with equivalent impulse current and leakage current through a human body**

### HH.3 Conditional dependent thresholds

In circuits separated from DC+ and DC–, some components may bridge that insulation/separation. For example: the EMC filter may have Y-capacitors from live parts to the protective conductor, or a voltage measurement will use some high-value resistances across the insulation, or an EV/battery system will have a parasitic capacitance between the vehicle power supply circuit and the vehicle chassis, etc. The currents that can flow through these components can form a hazard, and therefore need to be limited to protect against harmful electric shock. The current flowing through such capacitances constitutes a hazard due to the impulse current, and the resistances to ground constitutes a hazard due to the continuous current flowing through them.

For different types of operation or failures, different limits are used. In IEC 61140:2016, 5.2.7, the leakage current and energy due to a touch impulse current is limited to the following:

- less than the threshold of perception: 0,75 mA AC, or 2 mA DC and 5  $\mu$ J, under normal operation;
- less than the threshold of muscular reaction: 3,5 mA AC, or 10 mA DC and 0,5 mJ under abnormal or (single) fault conditions.

To this, this document, due to failure of basic and fault protection between the DC circuit and the ordinary person, adds the following:

- less than the threshold of strong involuntary muscular contractions: curve b in IEC 60479-1:2018 due to leakage currents;
- less than the threshold of ventricular fibrillation: curve c1 in IEC 60479-1:2018 or IEC 60479-2:2019 due to the touch impulse current.

Other standards may recommend different thresholds, depending on the risk.

For example: In the case of household appliances, a person/human body touching the metal case of a household appliance under normal operation should not be exposed to a perceivable current. If the protective conductor fails, a small current may be perceived, but this should not result in a strong muscular reaction. If, in addition to that, there is a failure from the live part to the chassis/enclosure of the household appliance, resulting in a second fault, a hazardous touch current may flow until an RCD in the fixed installation disconnects the supply in the appropriate time or less to prevent ventricular fibrillation.

Currently, there are no RCDs for DC, and the voltages used at side B live parts of EV supply equipment can be  $\leq 1\,500$  V DC, which would require much faster reaction times in the order of approximately 1 ms, which are technically not feasible for electro-mechanical disconnection devices. Therefore, the only available provision is by limiting the touch current and touch impulse current supplied by the impedance of the components bridging the insulation/separation to the protective conductor and other circuits.

### HH.4 Hazards due to leakage between side B live parts and the protective conductor

Due to aging (the influence of contamination, moisture, etc., over the lifetime of a product), there will be leakage additional to that of the designed components. There can be a need to ensure that this combination of bridging components and additional leakage stay within the bounds to which the EV supply equipment has been designed. An IMD measures the combined resistances of the side B live parts to the protective conductor and will therefore be able to detect when the system is not able to meet the designed limitations.

In ISO 6469-3:2021, 6.3.3, the EV can use basic insulation if the touch current is limited to 25 mA and the energy of the touch impulse current due to the Y-capacitors is limited to 0,2 J.

The EV design can limit the energy of the touch impulse current due to the Y-capacitors by limiting the total capacitance in the system but has to take into account that the EV supply equipment has a maximum limit of 1µF, or 500 nF for DC+ and DC– as per 8.105.1. Due to aging, the capacitance can reduce, but this will not constitute an additional hazard. The EV supply equipment design cannot expect that the EV will limit the energy in the touch impulse current due to the Y-capacitors and therefore needs to consider that maximum Y-capacitance that is allowed for the EV in ISO 17409:2020 or ISO 5474-3<sup>11</sup>.

Previous editions of ISO 6469-3 required a minimum insulation resistance of 100 Ω/V between side B live parts and the vehicle chassis; therefore, the EV supply equipment should not use a lower trip level for the IMD. The insulation resistance can degrade and become less, which results in a higher steady-state touch current. Therefore, the IMD triggers an error shutdown when the measured insulation resistance drops to < 100 Ω/V. When considering that the IMD also adds to the touch current, the total touch current should remain < 25 mA.

If it is not possible for the EV design to meet the requirements of limitation of touch current or limitation of energy in the touch impulse current, the design of the EV needs to ensure that live parts of the vehicle power supply circuit are protected by alternative measures, for example, double or reinforced insulation. In case the double or reinforced insulation, or protective shielding has failed, a different threshold for the touch current and energy in the touch impulse current can be used.

The EV supply equipment is unable to determine if the EV is designed with only basic insulation and a limitation of touch current and a limitation of energy in the touch impulse current, or alternative measure. Therefore, the IMD needs to detect when the resistance of the system drops to < 100 Ω/V and trigger an error shutdown. The capacitance, as considered in this document, is the same as previous editions. EVs may rely on this limitation for their design.

## **HH.5 Balanced versus unbalanced voltages at side B live parts (DC+/DC–)**

Because the side B of the EV supply equipment and vehicle power supply circuit are separated from the protective conductor and any other circuit, the voltage of each side B live part (DC+/DC–) to the protective conductor is not clearly defined.

The IMD uses this to apply a common mode signal to the side B live parts (DC+/DC–), for example through a significant resistance. Any asymmetry, due to design or leakage, can shift the potential of a side B live part (DC+ or DC–) to the potential of the protective conductor/vehicle chassis, thereby shifting the voltage of the other side B live part (DC+ or DC–) to a voltage further away from the protective conductor/vehicle chassis. If a human body would touch one of the DC live parts when the voltage to the protective conductor/vehicle chassis is higher due to an unbalance, the impulse current that human body is exposed to is significantly higher compared to a balanced system.

If the designed resistance to the protective conductor of the system is high, already a small asymmetric leakage current can shift the voltage of one side B live part (DC+/DC–) far away from the protective conductor. When the designed resistance to the protective conductor of the system is lower, this effect will be limited. Because the IMD will trigger an error shutdown and terminate the communication session at a predetermined limit, the maximum voltage between the side B live part (DC+/DC–) and the protective conductor will be less when the design resistance to protective conductor is lower, therefore the touch impulse current will be greatly reduced.

---

<sup>11</sup> Under preparation. Stage at the time of publication: ISO DIS 5474-3:2023.

The resistances to the protective conductor and their distribution therefore have a significant impact on the available touch impulse current, but also are the cause of a steady-state touch current once the Y-capacitors have been discharged. An IMD measures the total resistance to the protective conductor, irrespective if it is symmetric or asymmetric. The effect on the distribution of charge and the actual touch current that flows through the human body can be different.

A trade-off needs to be made between the steady-state touch current and the distribution of charge in the Y-capacitors, in combination with the threshold of the IMD.

## HH.6 Insulation monitoring device

One of the devices that adds resistance to the protective conductor in the EV supply equipment is the IMD at side B. An IMD according to IEC 61557-8 or equivalent, measures the total resistance between DC+/DC– and the protective conductor, excluding its own resistance. It is therefore possible to set the trip level to 100 k $\Omega$  for a 1 000 V DC system, and perform a communication session without a fault, even though the IMD itself has a lower resistance to the protective conductor. IEC 61851-23:2014 requires the IMD to trigger an error shutdown and terminate the communication session if "the actual total physical insulation resistance" between DC+/DC– to the protective conductor is less than the value calculated by 100  $\Omega$ /V multiplied by the rated maximum voltage at side B of the EV supply equipment (without negative tolerance). However, it is unclear if, in practice, the resistance to the protective conductor of the IMD has been considered.

Based on IEC 61557-8 or equivalent, the resistance to the protective conductor of the IMD can be relatively low, providing balancing of the charge in the Y-capacitors. However, the dynamic behaviour of the IMD measurement needs to be considered. Depending on the used IMD measurement technology (for example, the alternating switching of resistors against the protective conductor), stable balancing cannot be guaranteed.

In SAE J1772:2017, 6.5.4.2.4 requires an insulation resistance of either side B live part to the protective conductor of  $> 50_{+10}^0$  k $\Omega$  (100  $\Omega$ /V at 500 V). The IMD resistance to the protective conductor has to be significantly higher, because SAE J1772:2017, 6.5.4.1, states that the insulation resistance of each side B live part (DC+/DC–) includes any measuring device and that the total insulation resistance is the parallel combination of the insulation resistances of both side B live parts (DC+/DC–). The total insulation resistance of side B shall be  $\geq 1,25$  M $\Omega$ , including any measurement/monitoring devices. This implies  $\geq 2,5$  M $\Omega$  insulation resistance between each side B live parts (DC+/DC–) and the protective conductor for an EV supply equipment with insulation resistance equally distributed between each side B live part (DC+/DC–) and the protective conductor. As a result, the impact of the IMD resistance to the protective conductor is not significant when it comes to steady-state leakage current; however, there is also no advantage of any balancing that a lower resistance to the protective conductor may enable.

For system A, an earth leakage current monitoring device is used instead of an IMD, where the threshold in 6.3.1.105 is based on 100  $\Omega$ /V multiplied by the rated maximum voltage at side B of the EV supply equipment. In AA.3.1.2, it is defined that the fault current from system A shall be less than or equal to DC-2, therefore system A allows for relatively low resistances to the protective conductor for the detection system, which can be used to balance the charge in the Y-capacitors.

For system B, the detection of faults to the protective conductor during energy transfer is part of the EV, therefore the EV supply equipment only has an opportunity to take balancing into consideration during the cable-check phase.

## HH.7 IMD reaction time

The reaction time of the IMD is mainly influenced by the resistance to the protective conductor of its measurement circuit, and the total capacitance of the EV and EV supply equipment combined. If the resistance of the measurement circuit is lower, the reaction time can be shorter.

The EV is allowed a maximum capacitance according to ISO 17409:2020, 9.9, and should be  $\leq 2 \mu\text{F}$  between each side B live part (DC+/DC-) and the protective conductor (4  $\mu\text{F}$  in total) in order to guarantee the reaction time of the IMD. The reaction time needs to be defined because it bears relation to the protective conductor cross-sectional area as specified in 8.105.11. If the first fault to the protective conductor is detected in a reasonable time, a second fault that may result in a short-circuit current through the protective conductor can be avoided.

In UL 2231-2:2016, a 10 s reaction time is required. With requirements for the resistance to the protective conductor in SAE J1772:2017, this reaction time becomes unviable when EV Y-capacitance is included, but compliance testing is performed without this capacitance. In this document, the reaction time for system C is also set to 10 s, but compliance is tested with a representative EV Y-capacitance.

## HH.8 Conclusion

- If a limitation of touch current and touch impulse current is required, at a battery system voltage  $> 500 \text{ V DC}$ , the previous editions of all the standards do not leave enough Y-capacitance for the system, and the EV in particular.
- In this document, ISO 17409:2020 and SAE J1772:2017, protective separation (double insulation, reinforced insulation or basic insulation + protective shielding) between each side B live parts (DC+/DC-) and a human body are proposed, to allow higher Y-capacitance for the EV.
- For backwards compatibility with existing products, the EV supply equipment should maintain the same threshold for the IMD (100  $\Omega/\text{V}$  at 1 000 V) and, in the side B circuit, maximum Y-capacitance of 500 nF between each side B live part (DC+/DC-) and the protective conductor.
- By lowering the resistance to the protective conductor of the EV supply equipment, it is possible to:
  - trade off a larger steady-state touch current vs. the maximum energy in the touch impulse current due to the Y-capacitors, and
  - with a lower IMD resistance to the protective conductor, lower the reaction times and react in 10 s or less as defined in the UL 2231-2:2016, even when loaded with the maximum capacitance.
- Even if the (protective) separation between side B live parts (DC+/DC-) and a human body fails, the steady-state touch current can be limited to 25 mA (b curve), and the touch impulse current to less than the c1 curve to prevent ventricular fibrillation, as shown in Figure HH.4.

## Bibliography

IEC 60050-151, *International Electrotechnical Vocabulary (IEV) – Part 151: Electrical and magnetic devices*, available at [www.electropedia.org](http://www.electropedia.org)

IEC 60050-195, *International Electrotechnical Vocabulary (IEV) – Part 195: Earthing and protection against electric shock*, available at [www.electropedia.org](http://www.electropedia.org)

IEC 60050-312, *International Electrotechnical Vocabulary (IEV) – Part 312: General terms relating to electrical measurements*, available at [www.electropedia.org](http://www.electropedia.org)

IEC 60050-614, *International Electrotechnical Vocabulary (IEV) – Part 614: Generation, transmission and distribution of electricity – Operation*, available at [www.electropedia.org](http://www.electropedia.org)

IEC 60050-651, *International Electrotechnical Vocabulary (IEV) – Part 651: Live working*, available at [www.electropedia.org](http://www.electropedia.org)

IEC 60050-702, *International Electrotechnical Vocabulary (IEV) – Part 702: Oscillations, signals and related devices*, available at [www.electropedia.org](http://www.electropedia.org)

IEC 60050-826, *International Electrotechnical Vocabulary (IEV) – Part 826: Electrical installations*, available at [www.electropedia.org](http://www.electropedia.org)

IEC 60050-851, *International Electrotechnical Vocabulary (IEV) – Part 851: Electric welding*, available at [www.electropedia.org](http://www.electropedia.org)

IEC 60050-871, *International Electrotechnical Vocabulary (IEV) – Part 871: Active assisted living (AAL)*, available at [www.electropedia.org](http://www.electropedia.org)

IEC 60050-903, *International Electrotechnical Vocabulary (IEV) – Part 903: Risk assessment*, available at [www.electropedia.org](http://www.electropedia.org)

IEC 60068-2-11, *Environmental testing – Part 2-11: Tests – Test Ka: Salt mist*

IEC 60335 (all parts), *Household and similar electrical appliances*

IEC 60364 (all parts), *Low-voltage electrical installations*

IEC 60364-4-41:2005, *Low-voltage electrical installations – Part 4-41: Protection for safety – Protection against electric shock*

IEC 60364-4-41:2005/AMD1:2017

IEC 60364-5-55, *Electrical installations of buildings – Part 5-55: Selection and erection of electrical equipment – Other equipment*

IEC 60364-7-722, *Low-voltage electrical installations – Part 7-722: Requirements for special installations or locations – Supplies for electric vehicles*

IEC 60364-8 (all parts), *Low-voltage electrical installations*

IEC 60479 (all parts), *Effects of current on human beings and livestock*

IEC 60695-10-3, *Fire hazard testing – Part 10-3: Abnormal heat – Mould stress relief distortion test*

IEC 60695-11-10, *Fire hazard testing – Part 11-10: Test flames – 50 W horizontal and vertical flame test methods*

IEC 60950-1:2005, *Information technology equipment – Safety – Part 1: General requirements*  
IEC 60950-1:2005/AMD1:2009  
IEC 60950-1:2005/AMD2:2013

IEC 61508 (all parts), *Functional safety of electrical/electronic/programmable electronic safety-related systems*

IEC 61557-9:2014, *Electrical safety in low voltage distribution systems up to 1 000 V a.c. and 1 500 V d.c. – Equipment for testing, measuring or monitoring of protective measures – Part 9: Equipment for insulation fault location in IT systems*

IEC 61558-2-6, *Safety of transformers, reactors, power supply units and combinations thereof – Part 2-6: Particular requirements and tests for safety isolating transformers and power supply units incorporating safety isolating transformers for general applications*

IEC 61643-41:–<sup>12</sup>, *Low-voltage surge protective devices – Part 41: Surge protective devices connected to DC low-voltage power systems – Requirements and test methods*

IEC TR 61850-90-8, *Communication networks and systems for power utility automation – Part 90-8: Object model for E-mobility*

IEC 61851-23:2014, *Electric vehicle conductive charging system – Part 23: DC electric vehicle charging station*

IEC 61851-23-1:–<sup>13</sup>, *Electric vehicle conductive charging system – Part 23-1: DC electric vehicle supply equipment – With an automatic connection system*

IEC 62196-3:2014, *Plugs, socket-outlets, vehicle connectors and vehicle inlets – Conductive charging of electric vehicles – Part 3: Dimensional compatibility and interchangeability requirements for d.c. and a.c./d.c. pin and contact-tube vehicle couplers*<sup>14</sup>

IEC 62305-4:2010, *Protection against lightning – Part 4: Electrical and electronic systems within structures*

IEC 62439 (all parts), *Industrial communication networks – High availability automation networks*

IEC 62909-1, *Bi-directional grid connected power converters – Part 1: General requirements*

IEC 62909-2, *Bi-directional grid-connected power converters – Part 2: Interface of GCPC and distributed energy resources*

IEC 62909-3, *Bi-directional grid connected power converters – Part 3: EMC requirements and test methods*<sup>15</sup>

---

<sup>12</sup> Under preparation. Stage at the time of publication: IEC CC 61643-41:2023.

<sup>13</sup> Under preparation. Stage at the time of publication: IEC/AFDIS 61851-23-1:2023.

<sup>14</sup> This publication has been withdrawn.

<sup>15</sup> Under preparation. Stage at the time of publication: IEC/PRVC 62909-3:2023.

IEC 62955, *Residual direct current detecting device (RDC-DD) to be used for mode 3 charging of electric vehicles*

IEC PAS 63454, *Conductive charging of electric vehicles – DC vehicle coupler configuration GG*

ISO/IEC 14543-4-3:2015, *Information technology – Home electronic systems (HES) architecture – Part 4-3: Application layer interface to lower communications layers for network enhanced control devices of HES Class 1*

ISO/IEC 17025:2017, *General requirements for the competence of testing and calibration laboratories*

ISO 5474-1, *Electrically propelled road vehicles – Functional requirements and safety requirements for power transfer – Part 1: General requirements for conductive power transfer*<sup>16</sup>

ISO 6469-3:2021, *Electrically propelled road vehicles – Safety specifications – Part 3: Electrical safety*

ISO 5474 (all parts), *Electrically propelled road vehicles – Functional requirements and safety requirements for power transfer*<sup>17</sup>

ISO 5474-3, *Electrically propelled road vehicles – Functional requirements and safety requirements for power transfer – Part 3: DC power transfer*<sup>18</sup>

ISO 11898-1, *Road vehicles – Controller area network (CAN) – Part 1: Data link layer and physical signalling*

ISO 15118 (all parts), *Road vehicles – Vehicle to grid communication interface*

ISO 15118-1:2019, *Road vehicles – Vehicle to grid communication interface – Part 1: General information and use-case definition*

ISO 15118-3:2015, *Road vehicles – Vehicle to grid communication interface – Part 3: Physical and data link layer requirements*

ISO 17409:2015, *Electrically propelled road vehicles – Connection to an external electric power supply – Safety requirements*<sup>19</sup>

CHAdeMO Association, CHAdeMO 3.0 inlet adapter performance confirmation sheet

EN 17186, *Identification of vehicles and infrastructures compatibility – Graphical expression for consumer information on EV power supply*

IEEE 2030.1.1-2015, *IEEE standard technical specifications of a DC quick charger for use with electric vehicles*

---

<sup>16</sup> Under preparation. Stage at the time of publication: ISO/DIS 5474-1:2023.

<sup>17</sup> Under preparation.

<sup>18</sup> Under preparation. Stage at the time of publication: ISO/DIS 5474-3:2023.

<sup>19</sup> This publication has been withdrawn.

SAE J1772:2017, *SAE electric vehicle and plug in hybrid electric vehicle conductive charge coupler*

SAE J1772:—, *SAE electric vehicle and plug in hybrid electric vehicle conductive charge coupler*<sup>20</sup>

SAE J2953/1:2019, *Plug-in electric vehicle (PEV) interoperability with electric vehicle supply equipment (EVSE)*

Electric Vehicle Power Supply System Association (EVPOSSA), *Guidelines of charge/discharge system for electric vehicle V2H/L DC version*

UL 2231-2:2016, *Personnel protection systems for electric vehicle (EV) supply circuits: Particular requirements for protection devices for use in charging systems*

---

---

<sup>20</sup> Under preparation.





INTERNATIONAL  
ELECTROTECHNICAL  
COMMISSION

3, rue de Varembé  
PO Box 131  
CH-1211 Geneva 20  
Switzerland

Tel: + 41 22 919 02 11  
[info@iec.ch](mailto:info@iec.ch)  
[www.iec.ch](http://www.iec.ch)